

# Serviços de Localização e Geoinformação

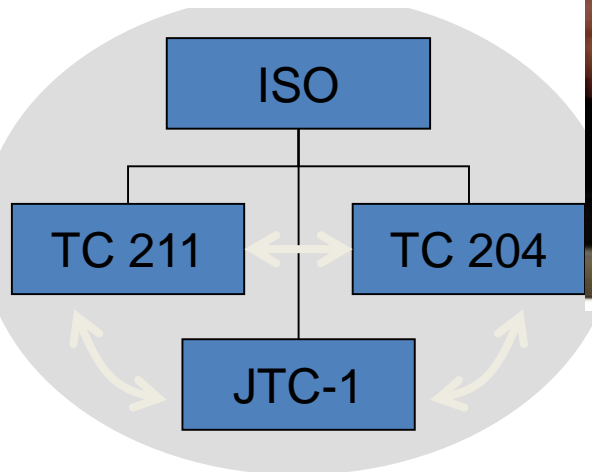
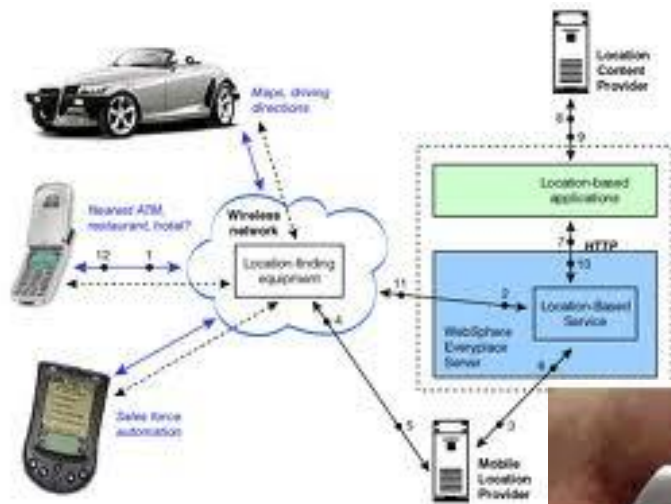

## ESA LEADS DRIVE INTO OUR 5G POSITIONING FUTURE

1 October 2019 A pair of testbed vehicles went out on the road in Germany to simulate the way we are all likely to be using 5G positioning services in the future. The field test focused on assessing the performance of highly-precise 'hybrid' satellite/terrestrial positioning for autonomous vehicles, drones, smart cities and the Internet of Things.

The two vehicles were driven for a week around Munich and the surrounding area in a variety of environments, from the open sky terrain surrounding the German Aerospace Center DLR's site in Oberpfaffenhofen to the deep urban canyons of the city's dense Maxvorstadt district.

As they drove they combined a broad range of on-board systems – including multi-constellation satellite navigation (combining Europe's Galileo, the US GPS, Russian Glonass and Chinese BeiDou), incorporating localised high-accuracy correction, and Long-Term Evolution 4G and Ultra-Wide Band terrestrial wireless broadband communication – to measure their positions and share them with one another, performing ongoing vehicle-to-vehicle ranging to simulate future 5G operating standards.



[Access the video](#)

The coming of the next generation of mobile phone networks, called 5G, promises much faster, more stable connectivity based on higher bandwidths and frequencies – but the ability to download a full movie in a matter of seconds is only the start. These increased capabilities will also open up a new range of services, many of them based around localisation.



Today we rely largely on satellite navigation to determine where we are. But our smartphones quietly blend satnav with other data sources to sharpen the accuracy of their results. That is why, for example, when you turn off your phone's WiFi receiver your smartphone will warn you its mapping will become less accurate – because it is also using WiFi maps as a reference source.

With 5G this trend of 'hybrid positioning' will accelerate. Multiple GNSS constellation will be employed together to increase accuracy, along

with localised correction systems. In addition the 5G cell network will provide additional corrections to enhance the GNSS localisation accuracy and to complement GNSS when satellites are not visible. This 5G 'New Radio' positioning accuracy will be enhanced by using steerable antennas on both the base station and the user terminal.



GNSS equipment aboard vehicles

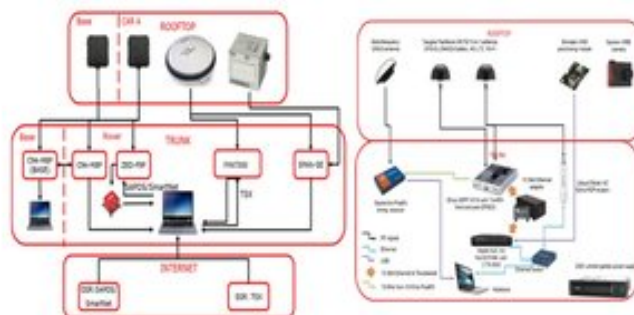

Testbed vehicle equipment

And because positioning performance will have to remain at the same high standard as user receivers move around – whether they be people, cars, shared bikes or drones – additional positioning solutions will also be employed, such as inertial sensors or device-to-device relative positioning.

Miguel Manteiga Bautista, Head of ESA's GNSS Evolution and Strategy Division in the Agency's

Directorate of Navigation explains: "For the hybrid positioning field-tests, ESA and its partners set up a collaboration with Deutsche Telekom for use of its 4G network in Munich including relevant information for positioning, and NovAtel, who provided state-of-the-art GNSS equipment and correction services, such as the satellite-based TerraStar-X."

## 5G GNSS Task Force

ESA oversaw this initial field test campaign as part of its 5G GNSS Task Force, coordinated with the [European Commission](#) and the [European GNSS Agency](#) through the Horizon 2020 Framework Programme for Research and Innovation in Satellite Navigation.

The field test campaign was undertaken by [DLR](#) and the [GMV](#) company, with contributions by engineers from [NovAtel](#), [u-blox](#) and [Deutsche Telekom](#) as well as ESA.

In 2016 the 5G GNSS Task Force within H2020 took the initiative to shape the support of high-accuracy positioning services in 4G and 5G networks, to contribute to the 3rd Generation Partnership Project, [3GPP](#), worldwide standardisation effort.

These field tests are executed within the GNSS Integration into 5G wireless networks or [GINTO5G](#) project. Undertaken through ESA's European GNSS Evolution Programme, this project is being executed by a consortium composed by GMV, [Universitat Autònoma de Barcelona](#) (UAB), DLR, u-blox and [Telefonica I+D](#).

Currently, UAB is involved in the thorough processing of all the data gathered during the field test campaign, leading into models and simulation tools and possibly additional field experiments.

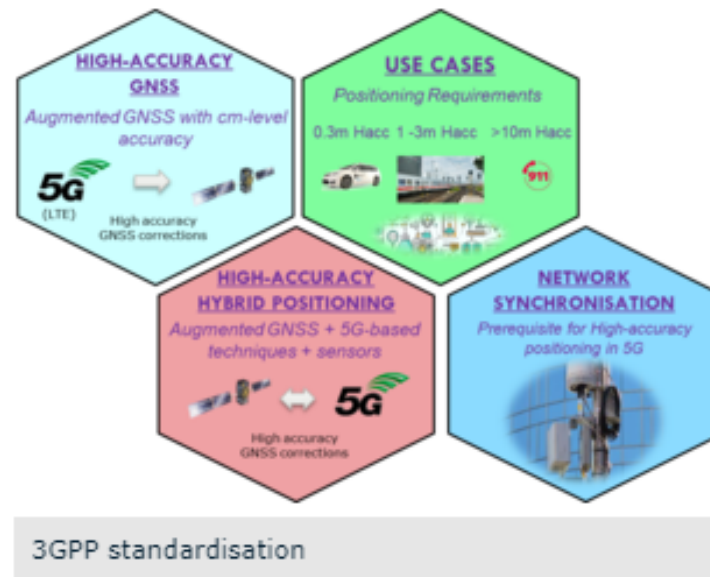



## 3GPP STANDARDISATION

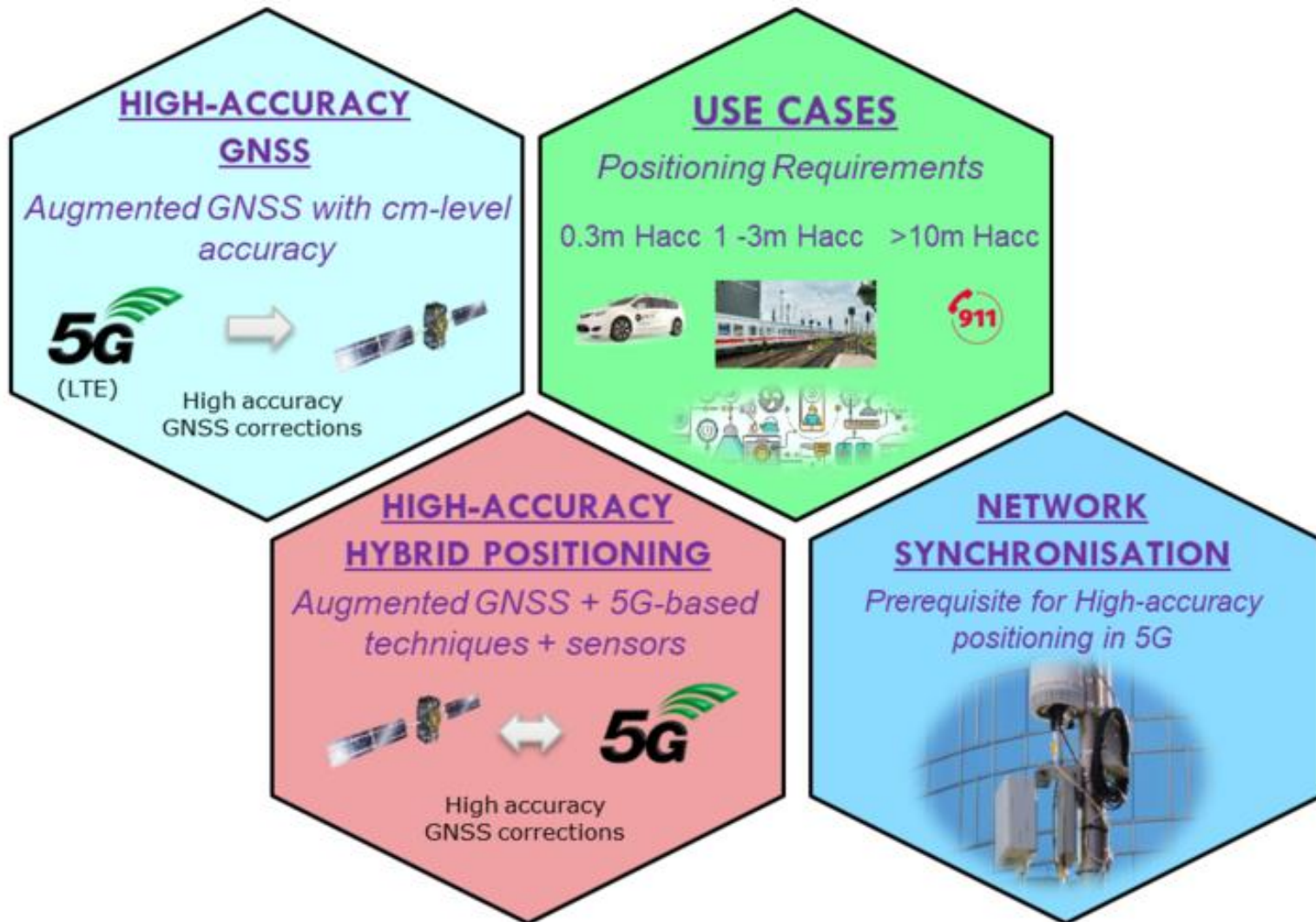

DOWNLOAD HI-RES

PNG

(273.46 kB)

## INTERNSHIPS AT ESA: APPLY NOW!

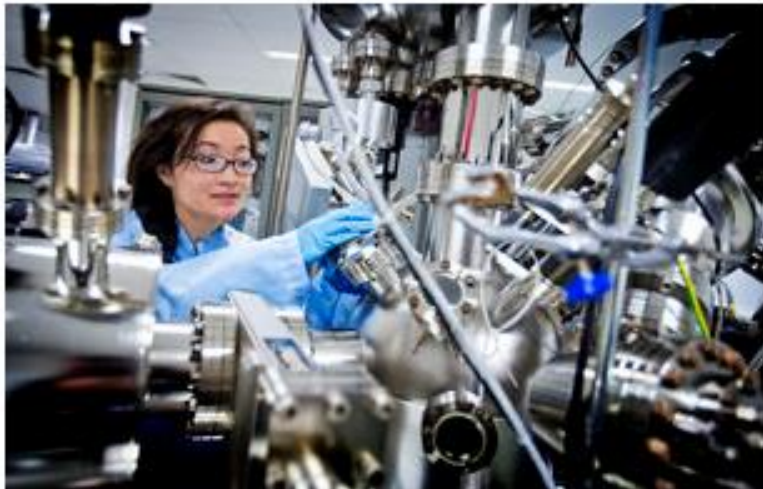

10 October 2019 Internship opportunities at ESA are now open for applications! Opportunities are available in most ESA establishments in engineering, science, IT, natural/social sciences, business and administration services and will be open for one month.

Student internships last from three to six months, with preference being given to longer internships.

### Who can apply?

To apply, you need to be

- A student, preferably in your final or second-to-last year of a university course at masters level (or equivalent).
- A citizen of one of the following [ESA Member States](#): Austria, Belgium, the Czech Republic, Denmark, Estonia, Finland, France, Germany, Greece, Hungary, Ireland, Italy, Luxembourg, the Netherlands, Norway, Poland, Portugal, Romania, Spain, Sweden, Switzerland, and the United Kingdom. Nationals from Slovenia, as an Associate Member, or Canada as a Cooperating State, can apply as well as those from Bulgaria, Cyprus, Latvia, Lithuania and Slovakia as [European Cooperating States](#).

### How to apply

# Career Opportunities

## Search for Openings

Keywords  ?

Exact Match

in job title

in job title or description

Establishment

10 Jobs match the selections

[Save this search](#)

10 Jobs matched your search

Items per page  Page  of 1

Sort by:

[Intern in the Space Transportation Development Department](#)

Req ID 8884 - Posted on 11/10/2019 -

[Intern in the Mission Management and Ground Segment Department](#)

Req ID 8871 - Posted on 11/10/2019 -

[Intern in the Mission Management and Ground Segment Department](#)

Req ID 8863 - Posted on 11/10/2019 -

[Intern in the Member States Relations and Partnerships Office](#)

Req ID 8864 - Posted on 11/10/2019 -

[Intern in the IT Security Section](#)

Req ID 8872 - Posted on 11/10/2019 -

[Intern in the European Center for Space Record / DG Cabinet](#)

Req ID 8870 - Posted on 11/10/2019 -

[Intern in the ESRIN Estates & Facility Management Division](#)

Req ID 8883 - Posted on 11/10/2019 -

[Intern in the Copernicus Space Office](#)

Req ID 8889 - Posted on 11/10/2019 -

[Intern in the Communication Department](#)

Req ID 8881 - Posted on 11/10/2019 -

[Intern in Earth Observation Future Systems Department \(EOP-Φ\) on Data Analytics with Artificial](#)

Req ID 8882 - Posted on 11/10/2019 -





# Learn How to Add Geocoding-as-a-service to Your Favorite Desktop GIS

Wednesday, October 30th 6:00pm - 6:30pm

Overview

Register

Share



Access highly accurate global geocoding-as-a-service capabilities directly within the most popular desktop GIS software systems including MapInfo® Pro, ArcGIS® and QGIS. Without any programming necessary, we will demonstrate how to enable your GIS solution to obtain accurate geocoding directly

from your desktop.

In this webinar you will:

- learn the deployment options
- see a demonstration of our geocoding API in action

## Speakers

Jon Spinney, Director of Product Management, Pitney Bowes

## Speakers



**Jon Spinney**

Director of Product Management, Pitney Bowes



**Kapil Dhawan**

Fellow & Lead Architect, Pitney Bowes

# Sumário

---

- A Sociedade da Informação
- A Cidade Digital
- A Nova Mobilidade
- Convergência Tecnológica
- A Internet e a Web
- As novas tecnologias da Informação e comunicação – Redes wireless
- Web Semantica
- Novas Tecnologias Informação e Comunicação
- Telecomunicações Móveis sem fios
- Outras redes móveis sem fios (WLAN, Bluetooth)
- Internet GIS e Wireless GIS

# O que são os Location Based Services?

“Os Serviços baseados na localização (Location Based Services, LBS) são o fornecimento de serviços de informação e dados nos quais o conteúdo desses serviços é ajustado / condicionado à posição actual (ou futura) e o contexto do utilizador”

*Brimicombe e Li (2009)*

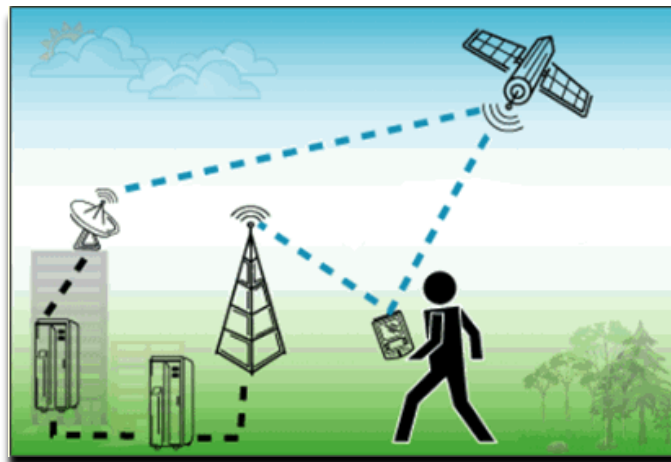



# O contexto dos LBS

As cidades são o lugar onde estão instaladas as principais forças económicas e sociais da sociedade da informação



**- Sociedade da Informação -**

**- Cidade Digital -**

**- Nova Mobilidade -**



São três facetas do mesmo fenómeno: o resultado da progressiva digitalização da actividade económica e social.

# A Sociedade da Informação

O que torna esta era “pós-industrial” na era “informacional”?

## ➤ O COMPUTADOR

Mas o elemento chave é o micro-processador (“chip”).  
Está presente em todos os equipamentos: veículos automóveis, telemóvel, leitor DVD, electrodomésticos, etc..

## ➤ “Networking”

Redes de computadores e de outros equipamentos baseados em microprocessadores usando modernas tecnologias de informação e comunicação (*Information and Communication Technologies, ICT*) ligando **computadores a computadores,**  
**computadores aos indivíduos e os**  
**indivíduos entre si** numa escala global

# A Sociedade da Informação

---

Alvin Tofler (1980) refere a Terceira Vaga como :

“A Economia da Informação”

“ A Nova Economia”

“Uma Economia na qual as fontes de produção e competitividade das empresas, regiões e países dependem cada vez mais no conhecimento, informação e da tecnologia do seu processamento, incluindo a tecnologia da gestão e a gestão da tecnologia”  
*Castells (1997, p.8)*



# Alvin Toffler

Alvin Toffler tornou-se conhecido do grande público por sua obra [\*A Terceira Vaga\*](#) de 1980, na qual descreve a evolução da sociedade humana, desde o tempo do predomínio das atividades agrícolas, passando pela fase industrial, até a era pós industrial, a era da informação.

Toffler described three historic waves of how civilization had progressed until this point. First, settling and starting to form an agricultural society, thus transitioning from a hunter-gatherer structure. Second, the industrial age with the modern, nuclear family in its center, providing mass everything (distribution, consumption, media, entertainment, education). His third wave is about the transition into the Information Age, when knowledge started taking precedence over material items in terms of what's valuable.



## The Third Wave

# A Sociedade da Informação

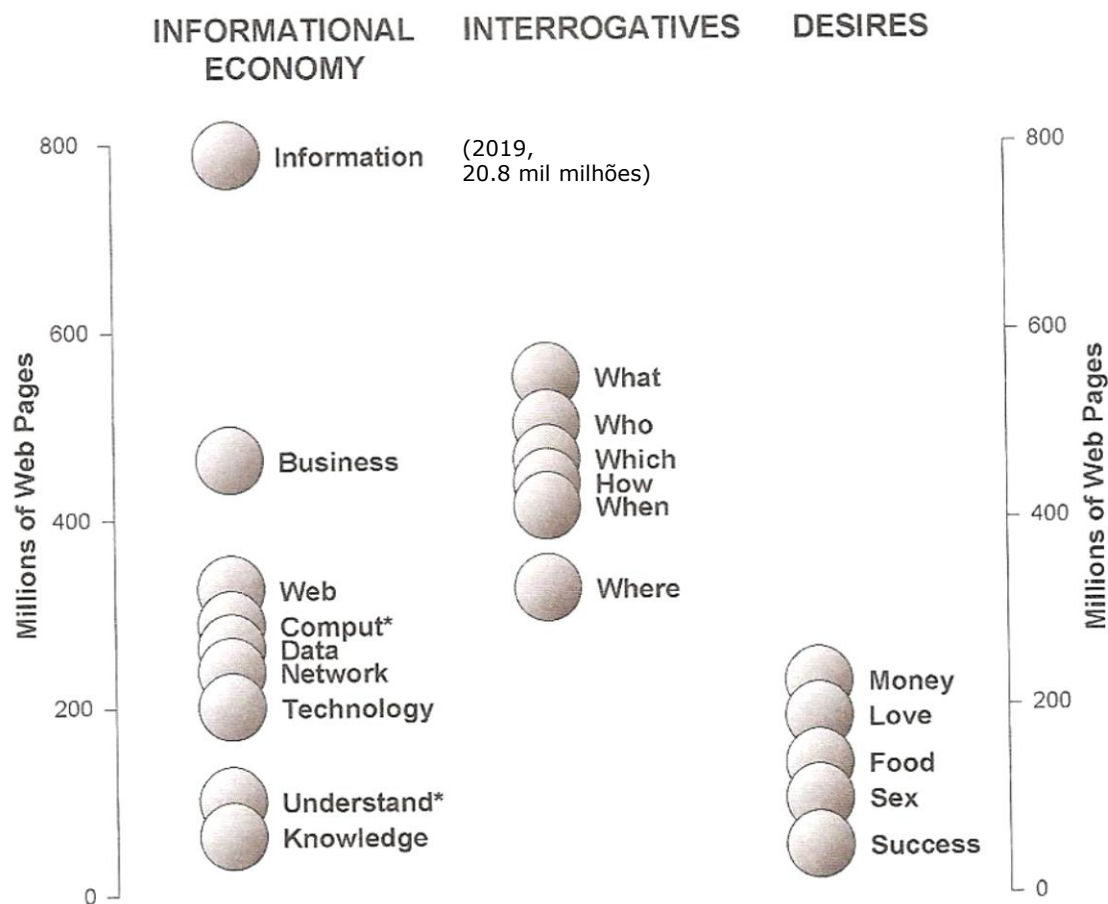

Foi realizada uma pesquisa na Web com palavras chave relacionadas com a:

“economia da informação”,

“interrogativas”

“desejos”

O resultado está expresso no gráfico

Os números apresentados neste gráfico cresceram cerca de 10 vezes nos últimos 5 anos.

# See what was trending in 2018 - Global

---

## Searches

- 1 World Cup
- 2 Avicii
- 3 Mac Miller
- 4 Stan Lee
- 5 Black Panther

---

## News

- 1 World Cup
- 2 Hurricane Florence
- 3 Mega Millions Result
- 4 Royal Wedding
- 5 Election Results

---

## People

- 1 Meghan Markle
- 2 Demi Lovato
- 3 Sylvester Stallone
- 4 Logan Paul
- 5 Khloé Kardashian

---

## Actors

- 1 Sylvester Stallone
- 2 Logan Paul
- 3 Pete Davidson
- 4 Bill Cosby
- 5 Noah Centineo

---

## Athletes

- 1 Tristan Thompson
- 2 Alexis Sánchez
- 3 Lindsey Vonn
- 4 Shaun White
- 5 Khabib Nurmagomedov

---

## Loss

- 1 Avicii
- 2 Mac Miller
- 3 Stan Lee
- 4 Anthony Bourdain
- 5 XXXTentacion



# Internet & Telecom

## Search on Google

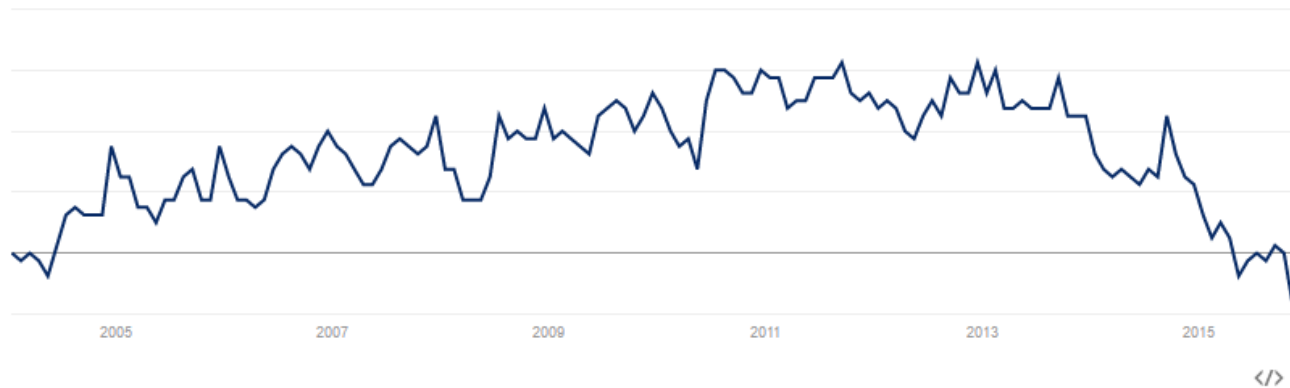

## Related searches ?

Topics			Queries		
	Top	Rising		Top	Rising
Google - Technology company	100	<div style="width: 100%;"></div>	google	100	<div style="width: 100%;"></div>
Yahoo! Mail - Website	65	<div style="width: 65%;"></div>	mail	80	<div style="width: 80%;"></div>
Yahoo! - Search engine company	60	<div style="width: 60%;"></div>	yahoo	60	<div style="width: 60%;"></div>
Email - Software Genre	35	<div style="width: 35%;"></div>	mail yahoo	45	<div style="width: 45%;"></div>
MSN - Portal	35	<div style="width: 35%;"></div>	msn	40	<div style="width: 40%;"></div>
Twitter - Website	30	<div style="width: 30%;"></div>	hotmail	35	<div style="width: 35%;"></div>

# Computer & electronics

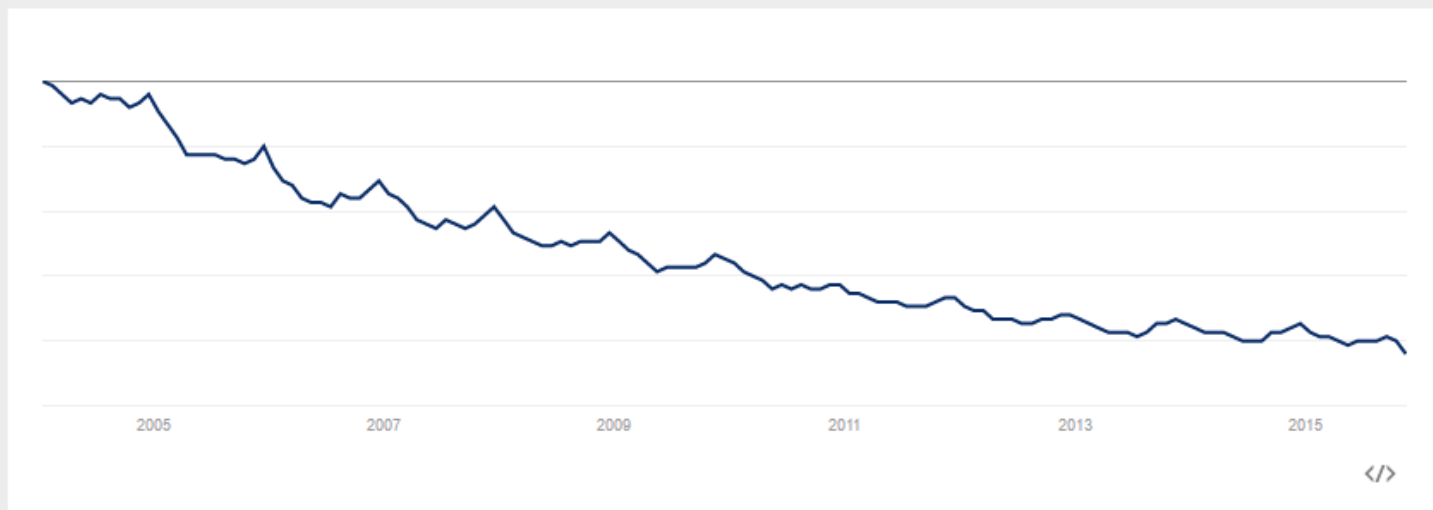

## Related searches ?

Topics	Top		Rising		Queries	Top		Rising	
	Value	Progress	Value	Progress		Value	Progress	Value	Progress
Download - Website Category	100	<div style="width: 100%;"></div>			download	100	<div style="width: 100%;"></div>		
Device driver - Type of software	35	<div style="width: 35%;"></div>			windows	75	<div style="width: 75%;"></div>		
Windows 7 - Operating System	30	<div style="width: 30%;"></div>			free	65	<div style="width: 65%;"></div>		
Google - Technology company	30	<div style="width: 30%;"></div>			google	45	<div style="width: 45%;"></div>		
Do it yourself - Website Category	25	<div style="width: 25%;"></div>			hp	30	<div style="width: 30%;"></div>		

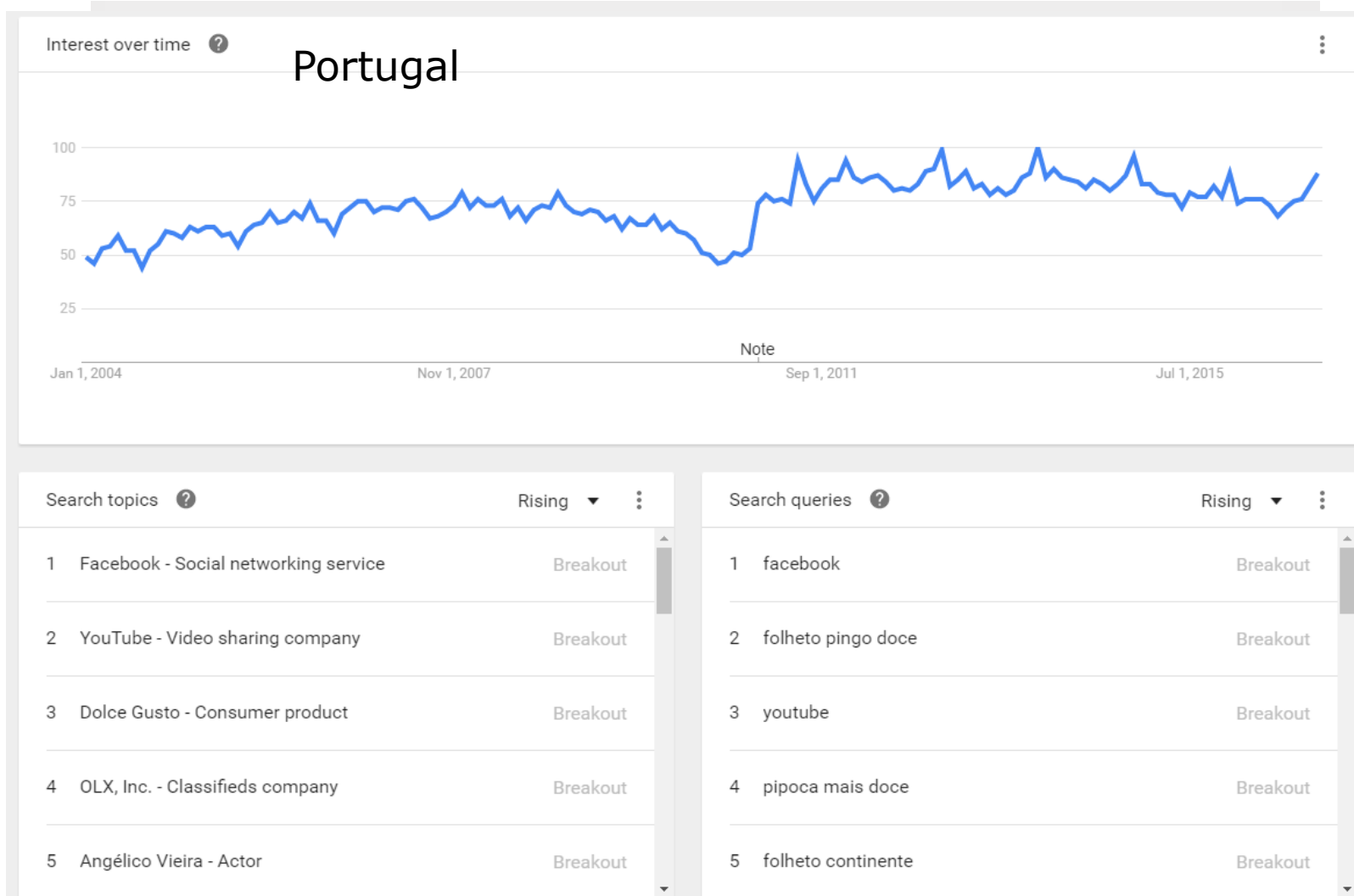

# Beauty & fitness

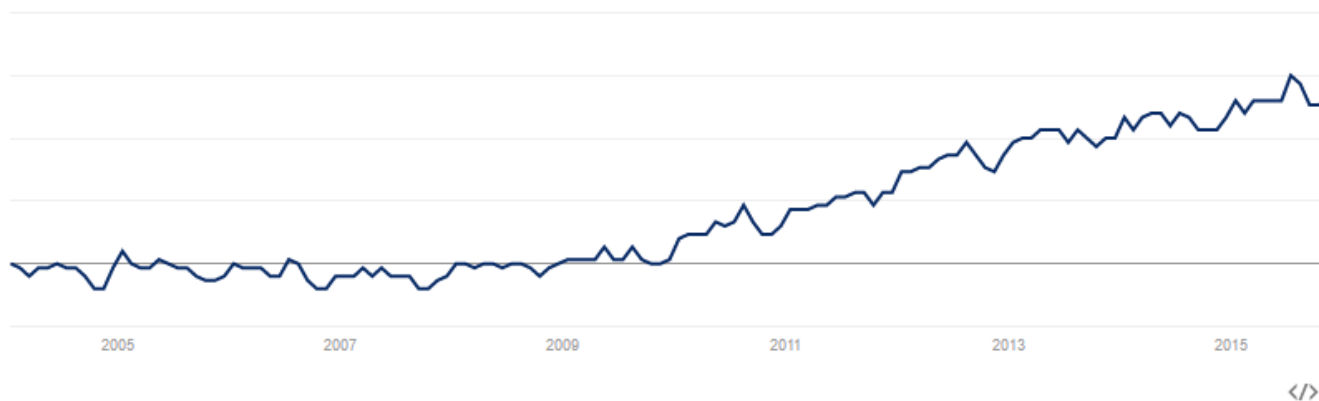

## Related searches ?

Topics	Top		Rising		Queries	Top		Rising	
	Value	Progress	Value	Progress		Value	Progress	Value	Progress
Tattoo - Visual Art Form	100	██████████			face	100	██████████		
Hairstyle - Award discipline	70	██████████			hair	60	██████████		
Physical exercise - Interest	40	██████████			tattoo	30	██████████		
Nail - Anatomical structure	40	██████████			fitness	20	██████████		
Cosmetics - Literature Subject	40	██████████			yoga	15	██████████		
Perfume - Product category	20	██████████			tattoos	15	██████████		



# Uso do computador vs Mobile

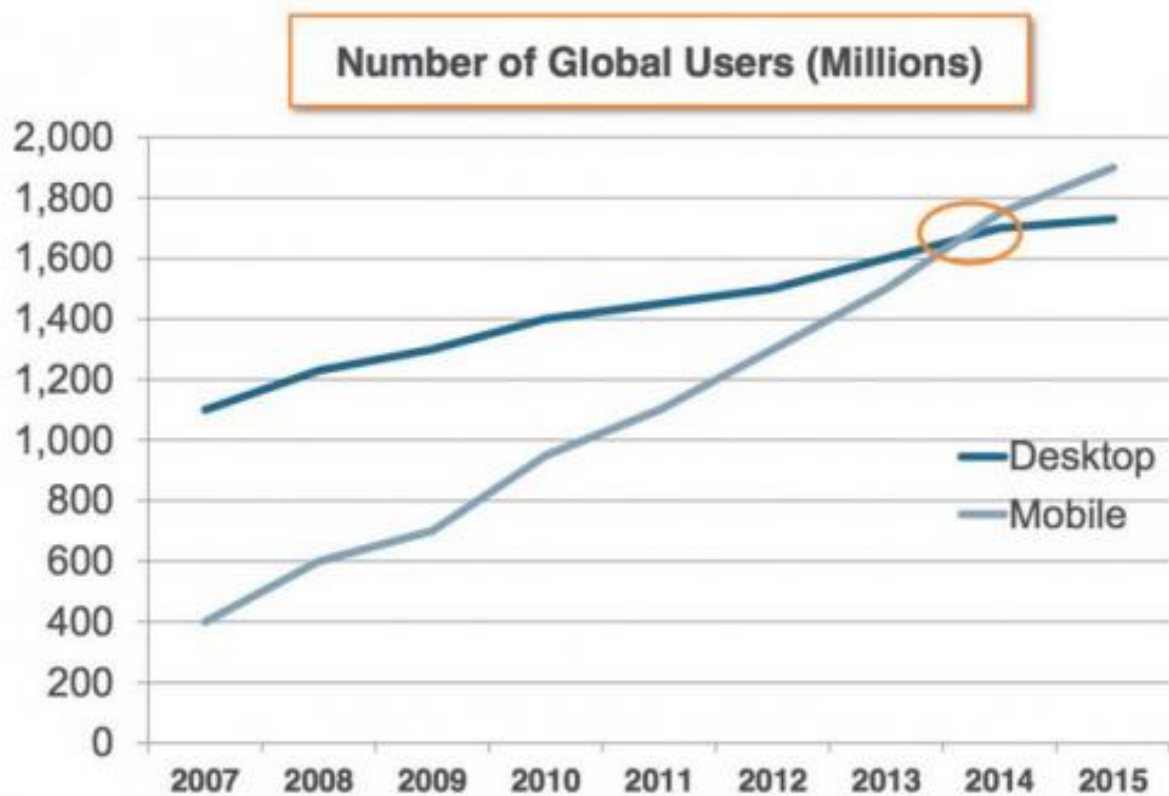

# Uso da internet vs dispositivo

Internet Usage (Engagement) Growth Solid  
+11% YY = Mobile @ 3 Hours / Day per User vs. <1 Five Years Ago, USA

Time Spent per Adult User per Day with Digital Media, USA, 2008 – 2015YTD

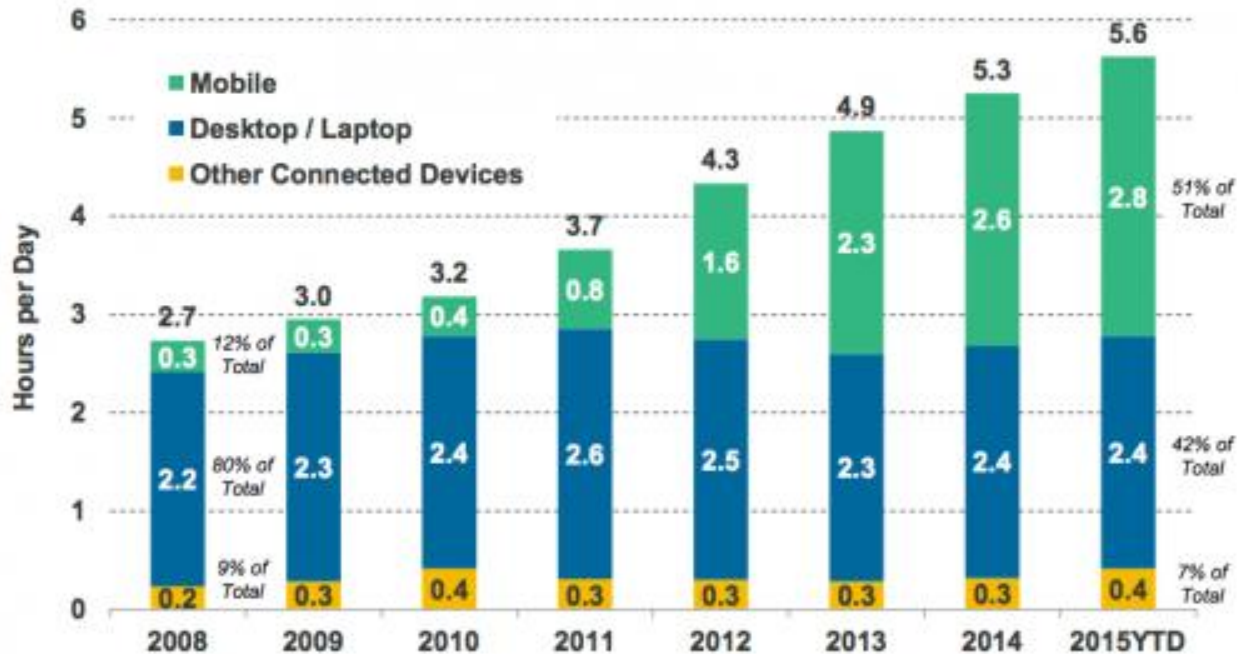

# A cidade digital

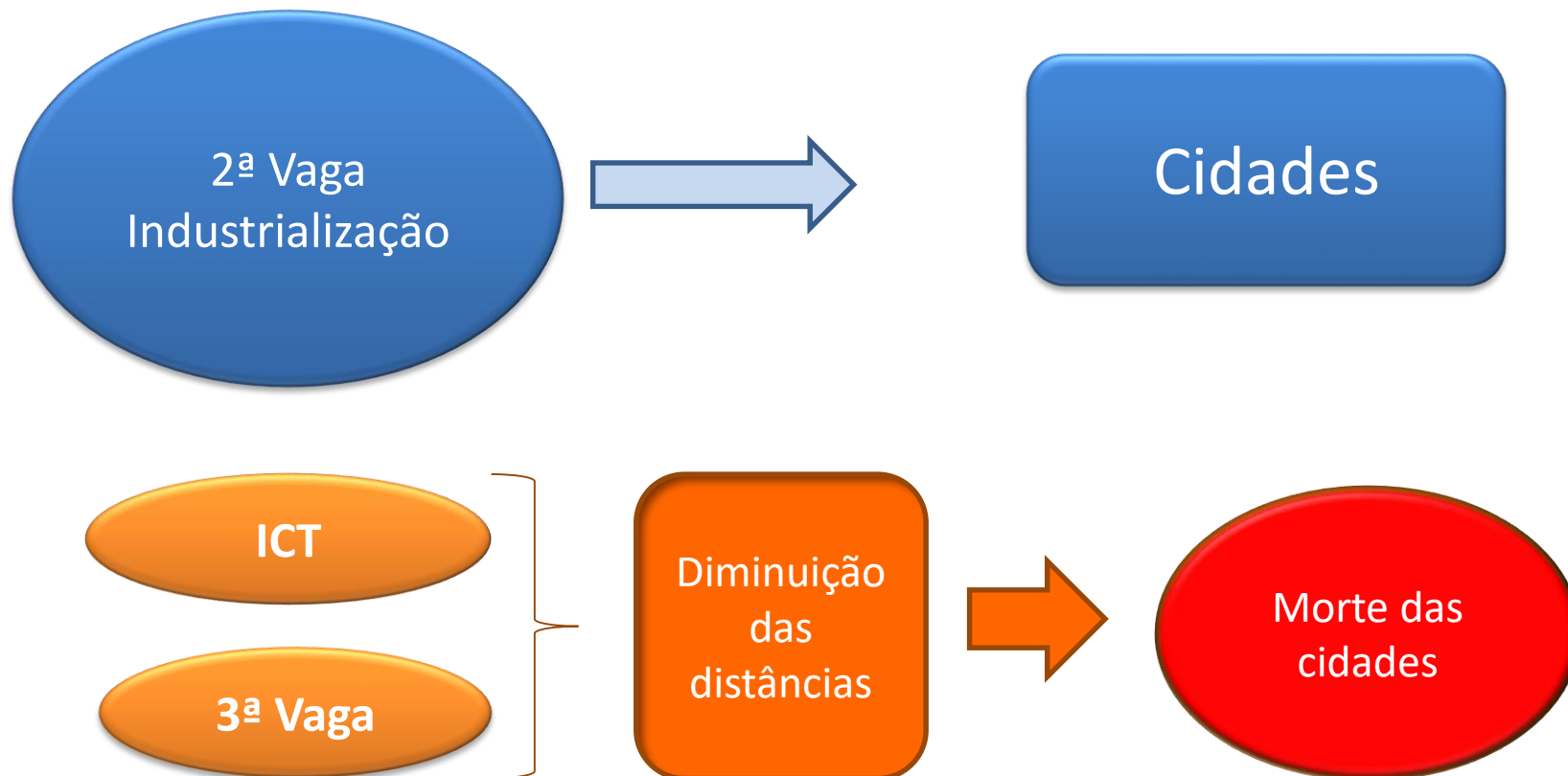

# A cidade digital

---

Graham e Marvin (1990) e Graham (1998) resumiram num conjunto de conceptualizações, em competição, a mudança na relação entre espaço, local e tecnologia de informação.

**Determinismo Tecnológico**

**Co-evolução dos espaços  
geográfico e electrónico**

**Recombinação através de  
"actor-networks"**



# Determinismo Tecnológico

(Technological Determinism)

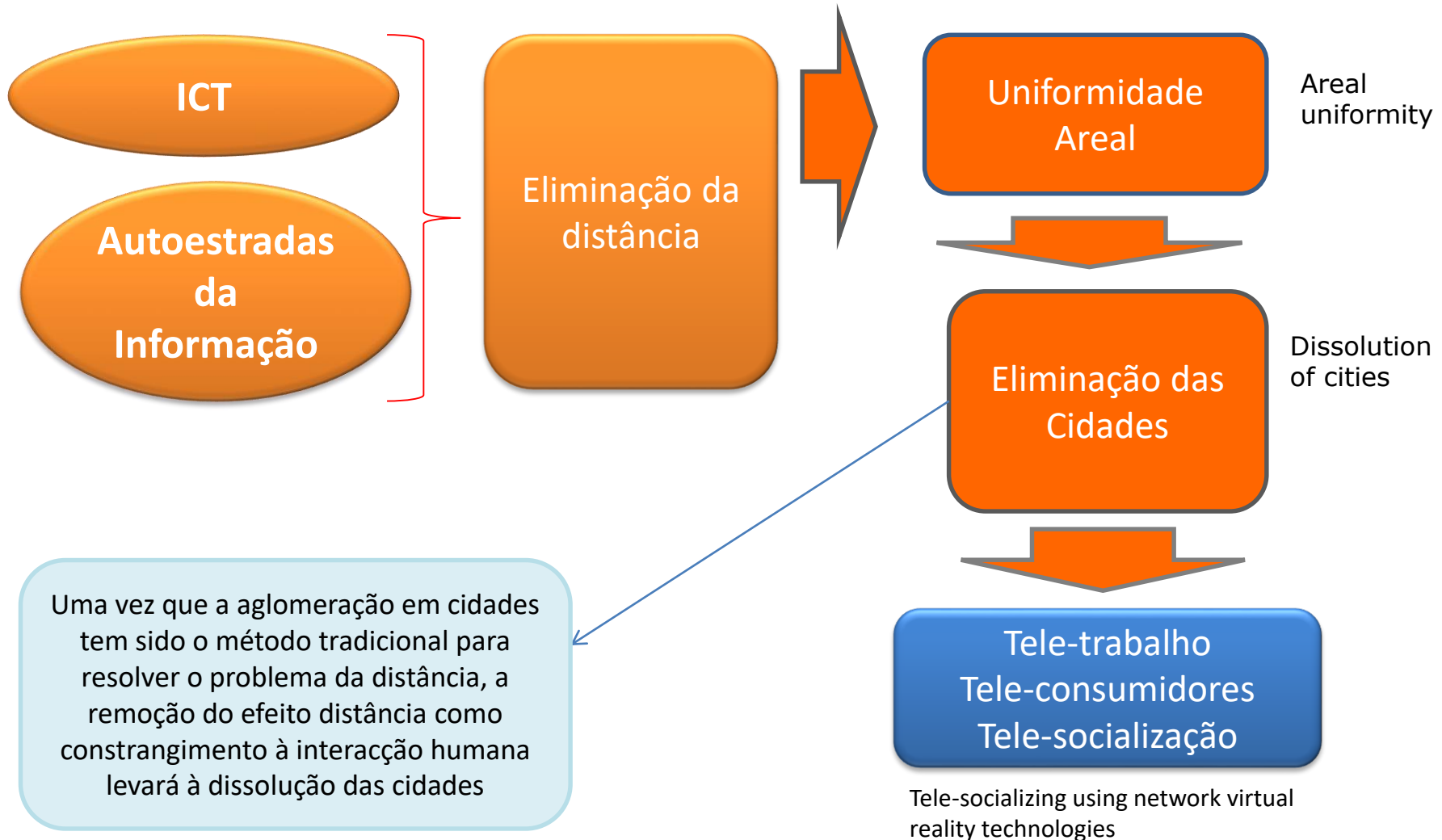

# Co-evolução dos espaços geográficos e electrónico

Surge em oposição ao anterior no que se refere à substituição integral do contacto directo "face-to-face"

As Redes Electrónicas vão evoluir conjuntamente com o espaço físico e com os processos sociais para criar novas sinergias e novas formas urbanas

Os residentes utilizarão os dispositivos digitais para melhorar o conhecimento e localização da cidade. Os LBS serão determinantes neste meio .

Este cenário intensificará o desenvolvimento da cidade em simbiose com o crescimento das redes de telecomunicação e da aceleração das taxas de transmissão.

As cidades vão redefinindo a sua forma devido às relações complexas entre Capital, Tecnologia e Espaço

# Recombinação através de redes de actores

Baseada na Teoria dos “Actor-Networks”

- As redes não são absolutos mas estão em permanente recombinação pelos seus actores em função do contexto social específico e capacidade de alteração no âmbito de cada utilização

Contudo, para as redes digitais muitos dos actores são máquinas (algoritmos) o que tornará difusa a fronteira entre a máquina e o homem e produzirá uma conceptualização cibernética da realidade.

A consequência serão novas formas de interacção humana, organização e controlo.

# Recombinação através de redes de actores

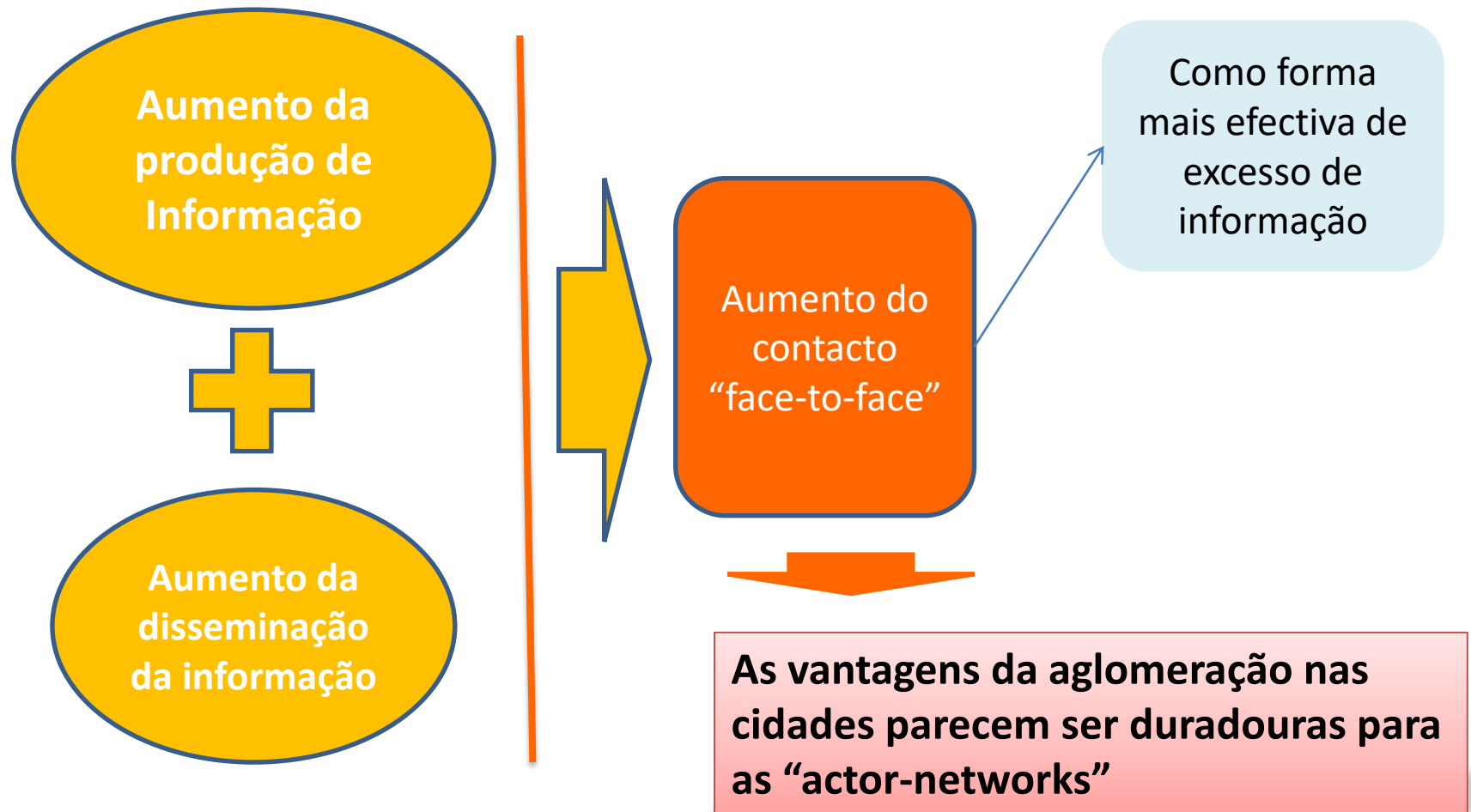



# A cidade digital



Apresentação

Carta de Princípios

OP 2011-2012

Prestação de Contas

Edições Anteriores

Multimédia



[www.cm-lisboa.pt/op/](http://www.cm-lisboa.pt/op/)

## Novidades

### Lançamento do OP

O Orçamento Participativo de Lisboa para 2011/2012 foi apresentado, dia 1 de Março, pela vereadora com o pelouro da Modernização Administrativa, Graça Fonseca, numa cerimónia onde também marcou presença o vereador da Educação, Manuel Brito. Na ocasião, que teve lugar na Escola EB 2/3 de Marvila, foi ainda apresentado o Orçamento Participativo Escolar.

O Orçamento Participativo (OP) visa contribuir para o exercício de uma intervenção informada, activa e responsável dos cidadãos nos processos de governação local, garantindo a participação dos cidadãos na decisão sobre a afectação de recursos às políticas públicas municipais e possibilitando, assim, ao executivo municipal corresponder às reais necessidades e aspirações da população.

A fase de apresentação das propostas para a cidade de Lisboa, no âmbito do OP 2011, tem início hoje, dia 1 de Março, e estende-se até ao dia 30 de Abril. Durante estes dois meses, os cidadãos podem fazer as suas propostas on-line, através do novo portal da participação de Lisboa, ou presencialmente, nas Assembleias Participativas que se vão realizar um pouco por toda a cidade.

A partir do dia 1 de Maio, cabe aos serviços municipais proceder à avaliação de todas as propostas apresentadas, transformando as que cumpram as normas de participação em projectos. Posteriormente, será aberto um período para reclamação e resposta, antes da fase da votação. Durante todo o mês de Setembro, os cidadãos são chamados a votar no projecto da sua preferência,

## Vídeos

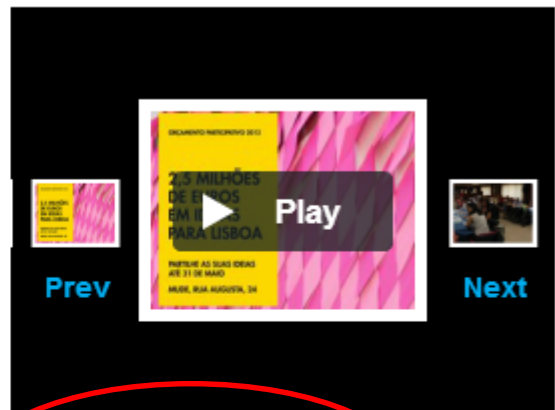

## Projectos Georeferenciados



# OpenCitySmart and Enhanced SDIs



'Smart Cities' are liveable, efficient and sustainable cities, where the vertical services are built on an existing, basic infrastructure. Two experienced Hungarian SMEs, Pro Urbe and Terra Studio, recently hosted a conference on Smart City/Smart Mobility in Budapest. Their message: to achieve the goals of environmental sustainability, we need tools that facilitate an interdisciplinary approach and that are aligned with the needs/interests of the city, its citizens and the wider community. Open source and open data hold the key, as explained here.

To achieve the goals of environmental sustainability, we need tools that provide an interdisciplinary approach for survey, evaluation and audit, studying best practices, concepts, strategies, actions and business plans, impact analysis,

involvement of solution providers, coordination, communication, community participation, education, ICT-supported integration, interoperability, optimisation, monitoring, etc. All of these must be aligned with the needs/interests of the city and its citizens, the wider community and society in general. Open source and open data enable effective cross-impact geospatial analysis between e.g. environment, mobility, people, government, economic development and lifestyle.

Given the current trends and related consequences from a global perspective, it is critical that we design and build Smart Cities. A population explosion is occurring simultaneously with a massive urban shift. The global population has trebled since 1950, when there was an even distribution between rural and urban areas, and today 80% of people in the developed world live in cities. Compounding this issue, we are consuming 1.5 times Earth's sustainable resources each year. This cannot continue. The world's cities must seriously address the issue of sustainable living. Sharing best practices and working collaboratively are key to solving these problems.

Collective problem-solving and sharing of solutions will also help us better appreciate our common needs and similar aspirations. In the CitySmart session of the NASA Europa Challenge, we will present open platforms and geospatial tools for building sustainable living solutions. These applications will contribute to an 'OpenCitySmart' suite of functionalities for

# A cidade digital

A CIDADE DIGITAL é o núcleo dos sistemas baseados na localização (LBS) bem como para a governança participativa e suporte à decisão

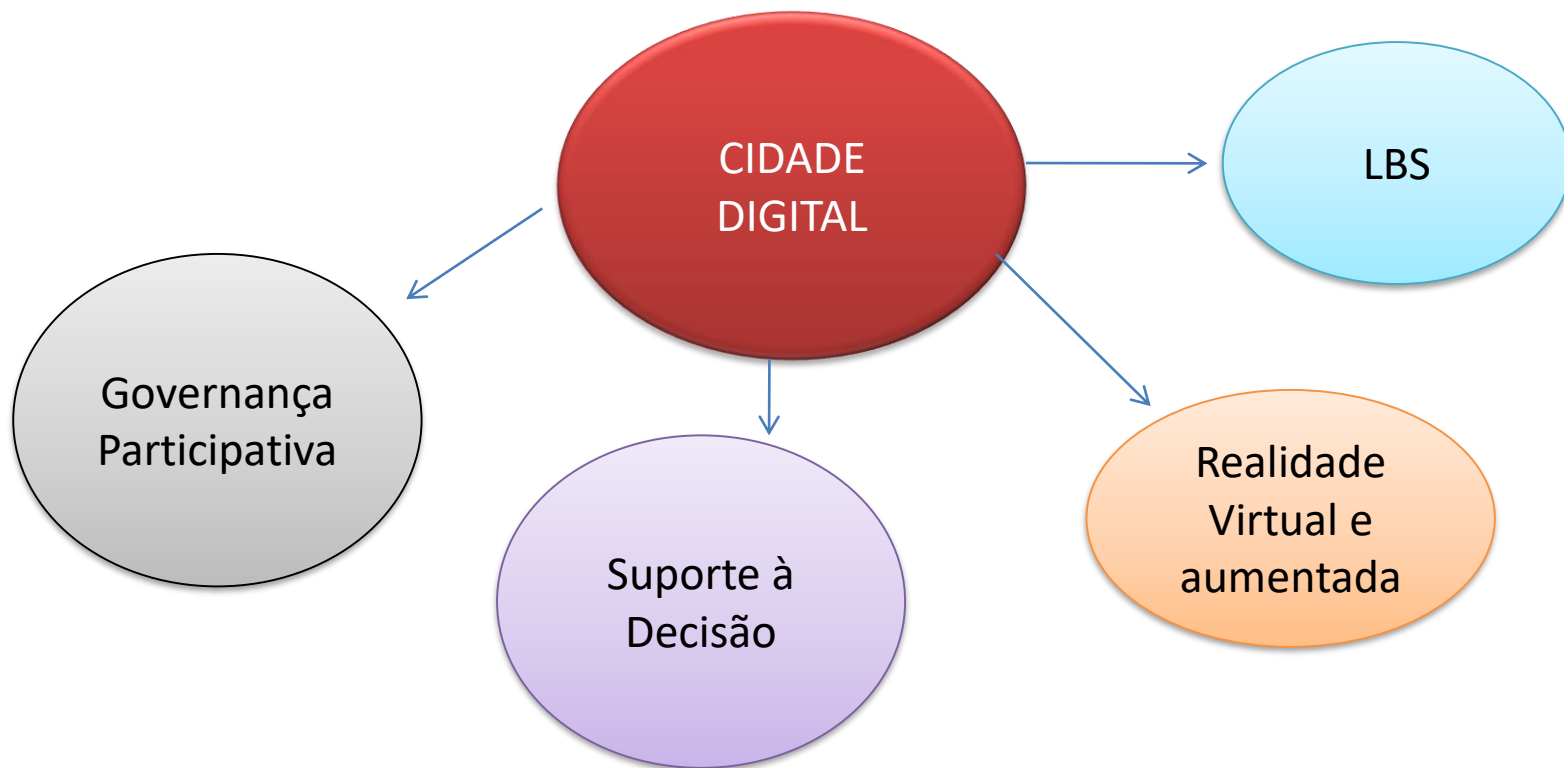





# A cidade digital



FRIDA V



LUDIGO HORIZONS



MEET YOUR  
HEARTBEAT TWIN



METACARTE



MONTRE VERTE  
urban awareness



REALITE AUGMENTEE  
MOBILE



ROBOT TOURISTE



SUR-IMPRESSIO

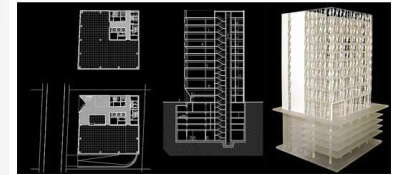

TELESCOPE DE  
REALITE AUGMENTEE



THEATRE DE GUIGNOL  
NUMERIQUE



TRANSPORTS  
AMOUREUX



URBADEUS



VOXSTRUMENTAL



HERITAGE 3D



AWDIOSOFT



# A Nova Mobilidade

## Fluxos de Informação e Capital produzem fluxos de Pessoas

Vimos como as TIC permitiram a dispersão de algumas actividades e a aglomeração de outras – redefinindo a forma das cidades e os padrões de trabalho e lazer – no qual o contacto face-a-face embora aumentado por dispositivos como os telefones móveis, desempenham um papel vital no fluxo da informação, ideias e inovação.



De uma forma ingénua podemos dizer que viajamos mais.

Podemos falar, conversar, ver clientes, colegas a 7000km de distância

Tornámo-nos geograficamente mais móveis



# A Nova Mobilidade

---

Sociedade da  
Informação

Cidade Digital

Nova  
Mobilidade

Location Based Services

Dados e informação “tailored” às circunstâncias e necessidades de cada um – como é pretendido e onde é pretendido.

Receber um aviso de tráfego congestionado (na estrada onde estamos a viajar)

# Convergência de Tecnologia

Os LBS são um conjunto de tecnologias heterogéneas:

- ❑ **Os SIG** e outras tecnologias espaciais
- ❑ **A Internet e Web**
- ❑ **Novas Tecnologias de Informação e Comunicação (NICT)**

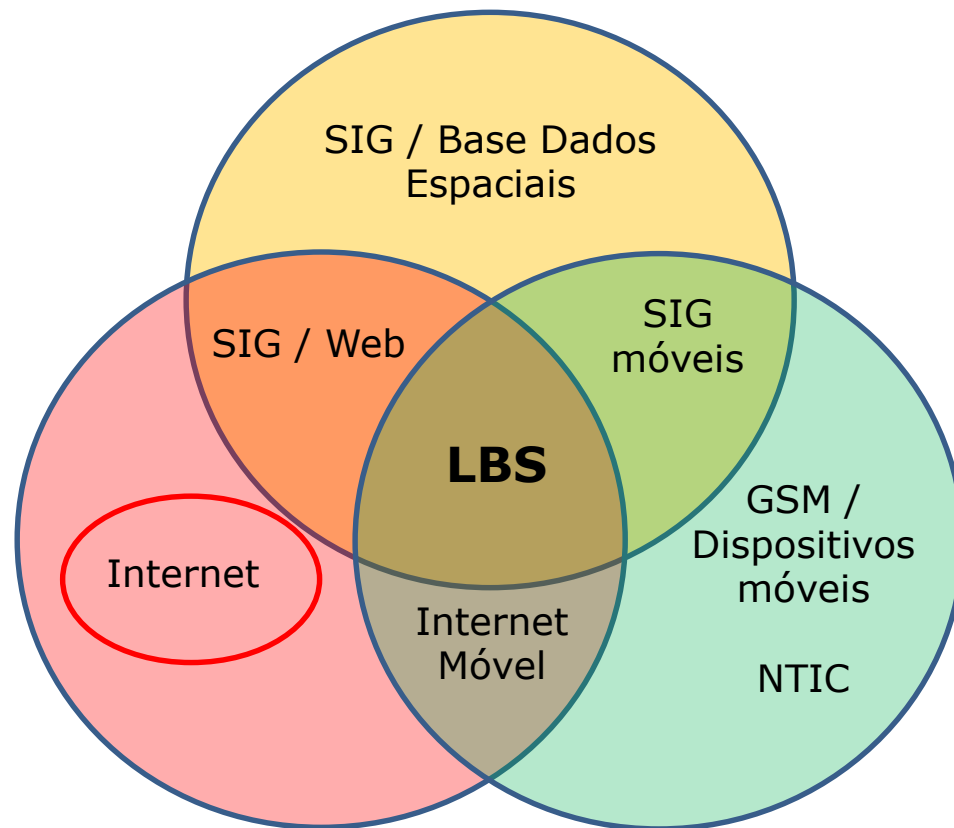

# A INTERNET

O início da era espacial (com o lançamento do Sputnik) em 1957 desencadeou o desenvolvimento da **ARPANET** (Advanced Research Projects Agency Network) a precursora da Internet.

A **ARPANET** foi desenvolvida pelo DARPA (Defense Advanced Research Projects Agency, USA) e ficou operacional em 1969.

Esta rede permitia transferir dados entre computadores que comunicavam na mesma rede (packet switching e TCP/IP).

O primeiro programa de **e-mail** (correio electrónico) foi criado por Ray Tomlinson em 1972 (BBN Technology)

Na década de 1970 e 1980 foram desenvolvidas várias redes:

SATNET: ligação via satélite (INTELSAT) entre os EUA e a Europa

BITNET: Rede desenvolvida pela IBM para e-mail e armazenamento de dados

CSNET: criada pela US National Science Foundation para instituições sem acesso à ARPANET

Em 1984 a ARPANET foi dividida em duas redes: uma para uso militar e outra para investigação.

No final da década de 1980 esta última foi melhorada designando-se por NSFNET (National Science Foundation NETwork) funcionando a 1.5 Mbps (conceito T1, EUA, linha a 1.5Mbps).

# Internet - WWW

---

Em 1989 alguns países como a Alemanha, Reino Unido, Holanda, Itália, Austrália, Nova Zelândia, Israel e México aderiram à INTERNET.

No início dos anos 1990 as redes adoptaram o conceito T3 (28 x linhas T1) a 45 Mbps, nas linhas alugadas (Service Providers), e os originais 50 Kbps da ARPANET foram descontinuados.

Foi também implementado o sistema de hipertexto (HTML) no CERN em Genebra, Suíça.

Em 1992 o CERN disponibilizou o primeiro browser World Wide Web (WWW ou simplesmente Web, Tim Berners-Lee)

# Internet - WWW

---

- 1992      foi criada a Internet Society.
- 1993      Disponibilizada uma interface gráfica para a Web “Mosaic for X”. Foi o primeiro “browser” (visualizador – ver dentro de..) da Web. O aparecimento dos browsers acelerou fortemente o uso da Internet.
- 1995      O acesso directo à NSF foi descontinuado e a ligação Internet passou a ser vendida por empresas, actuando como prestadores do serviço “**service providers**” contratados pela NFS. Passaram a ser cobrados valores pelos nomes dos domínios. (Anacom ?)
- 1996      A maior parte do tráfego da INTERNET é assegurado por **Internet Service Providers** (ISPs)



# Internet / Perspectiva Tecnológica

A **INTERNET** é uma rede de comunicações ligando muitas redes no mundo

A Internet usa a tecnologia “packet-switch” na qual os dados são divididos em pequenos pacotes (“packets”) e cada pacote é enviado individualmente através de uma série de “switches” (interruptores) conhecidos como “routers” através da internet.

No receptor os dados são “montados” na sua forma original quando os pacotes são recepcionados.

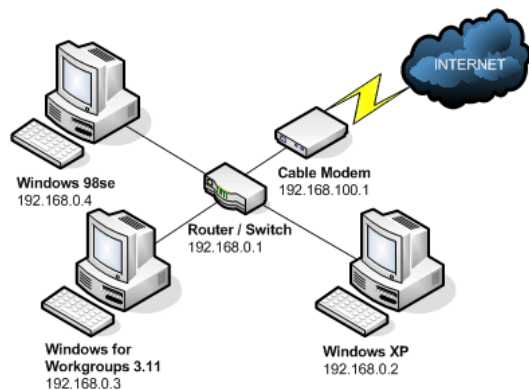

Existem vários protocolos na Internet para efectuar esta operação

TCP /IP é o mais usado  
Transmission Control Protocol / Internet Protocol

Protocolo que suporta aplicação multi-rede

Define o procedimento de fragmentação em pacotes a enviar para o endereço final

Quando os pacotes são enviados, cada pacote é colocado dentro de um envelope IP. O endereço do emissor e receptor figuram no envelope.

Quando os dados chegam ao receptor podem chegar a diferentes tempos via diferentes caminhos na rede. O que significa que os pacotes chegam fora da ordem inicial e podem ainda vir danificados e outros ficam perdidos na rede.

Quando se detecta a falta de alguns pacotes é enviado um pedido de retransmissão para esses pacotes voltarem a ser enviados



Podemo-nos ligar à Internet através de:

- LAN – Local Area Network
- Ligação banda larga
- Dispositivo (modem) cedido por um ISP.

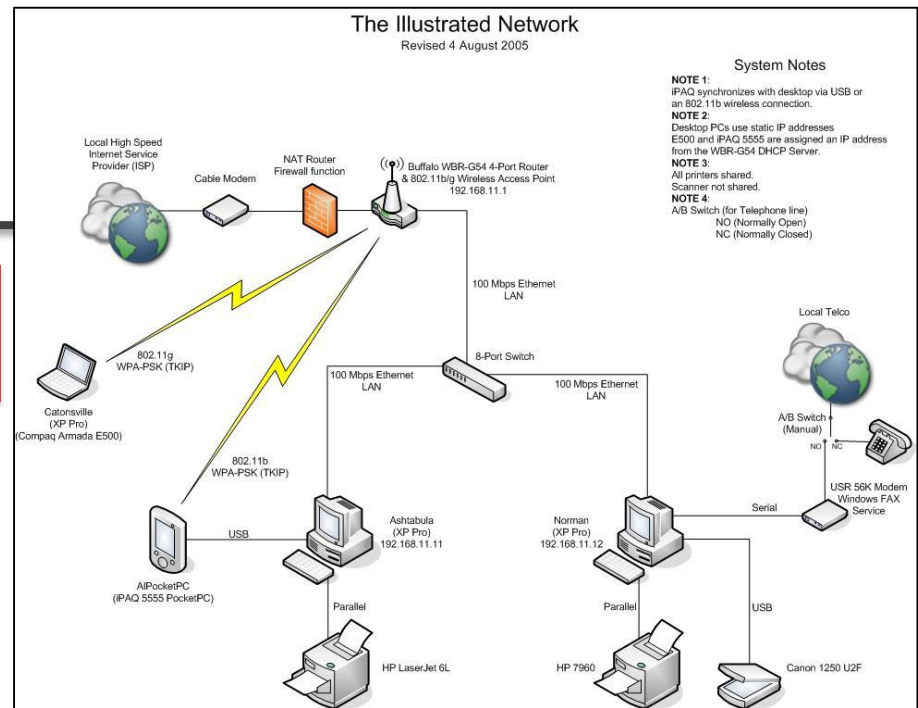

A LAN e os ISP ligam-nos à Internet através de “routers” (ou “bridges”). Os routers enviam a informação ou pedidos aos destinos na Internet.

Quando enviamos um e-mail, transferimos dados via FTP, ou acedemos a sítios Web, os pedidos ou a recepção dos dados nos servidores solicitados é feito através de uma série de routers na Internet.

# World Wide Web

A **Web** teve início no início da década de 1990 e tem sido usada para aceder, trocar, processar e disseminar informação e serviços ao público.

A Web funciona no modo cliente - servidor

O software cliente, conhecido como Web Browser (visualizador da teia) funciona no computador do utilizador, o software do servidor funciona num qualquer computador da Internet.

Quando o utilizador solicita informação através do Web Browser, o browser envia o pedido URL (Uniform Resource Locator) usando HTTP (Hypertext Transfer Protocol)

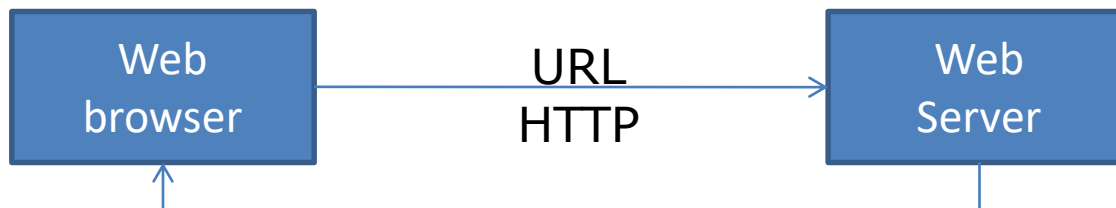

## Departamento de Engenharia Geográfica, Geofísica e Energia

### Navegação

- Home/Apresentação
- Organização ▶
- Ensino ▶
- Recursos Humanos ▶
- Alunos ▶
- Investigação
- Provas Académicas ▶
- Contactos

### Em destaque...



Licenciatura em  
Meteorologia,  
Oceanografia e Geofísica  
e Mestrado em Ciências  
Geofísicas [\[+\]](#)

▲ Licenciatura e Mestrado

http://degge.fc.ul.pt/ - Original Source

File Edit Format

```
4 <meta http-equiv="Content-Type" content="text/html; charset=iso-8859-15" />
5 <title>Departamento de Engenharia Geográfica, Geofísica e Energia DEGGE</title>
6 <link href="style.css" rel="stylesheet" type="text/css" />
7 <script src="SpryAssets/SpryMenuBar.js" type="text/javascript"></script>
8 <link href="SpryAssets/SpryMenuBarVertical.css" rel="stylesheet" type="text/css" />
9 </head>
10
11 <body>
12 <table width="923" border="0" align="center" cellpadding="0" cellspacing="0">
13   <tr>
14     <td colspan="4"></td>
15   </tr>
16   <tr>
17     <td width="15" rowspan="6" background="imagens/barra_esq.png">
20       <li><a href="index.php">Home/Apresentação</a></li>
21       <li><a class="MenuBarItemSubmenu">Organização</a>
22         <ul>
23           <li><a href="infraestrutura_servicos.php">Infraestrutura e Serviços</a></li>
24           <li><a href="orgaos_gestao_representacao.php">Órgãos de Gestão e Representação</a></li>
25         </ul>
26       </li>
```



# A evolução da Web

A WEB 2.0



Redes Sociais

Rede colaborativa

A possibilidade do utilizador gerar conteúdos





# A internet das coisas



## IoT in 2020

Analysts' original projections for the number of connected devices by 2020 [solid bars] varied by many billions. Some have ratcheted down expectations in newer forecasts [striped bars]. Conflicting definitions make it difficult to compare expectations. Some firms count smartphones, tablets, and laptops, while others (Gartner, International Data Corp.) do not.

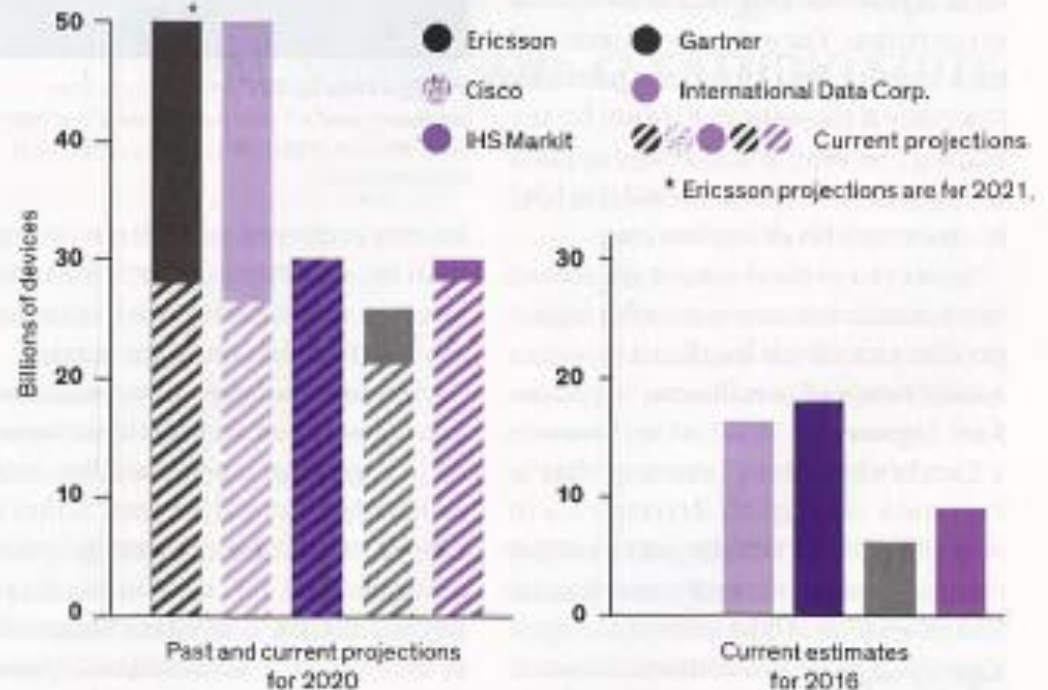

Os LBS são um conjunto de tecnologias heterogéneas:

- Os SIG e outras tecnologias espaciais
- A Internet e Web
- Novas Tecnologias de Informação e Comunicação (NICT)

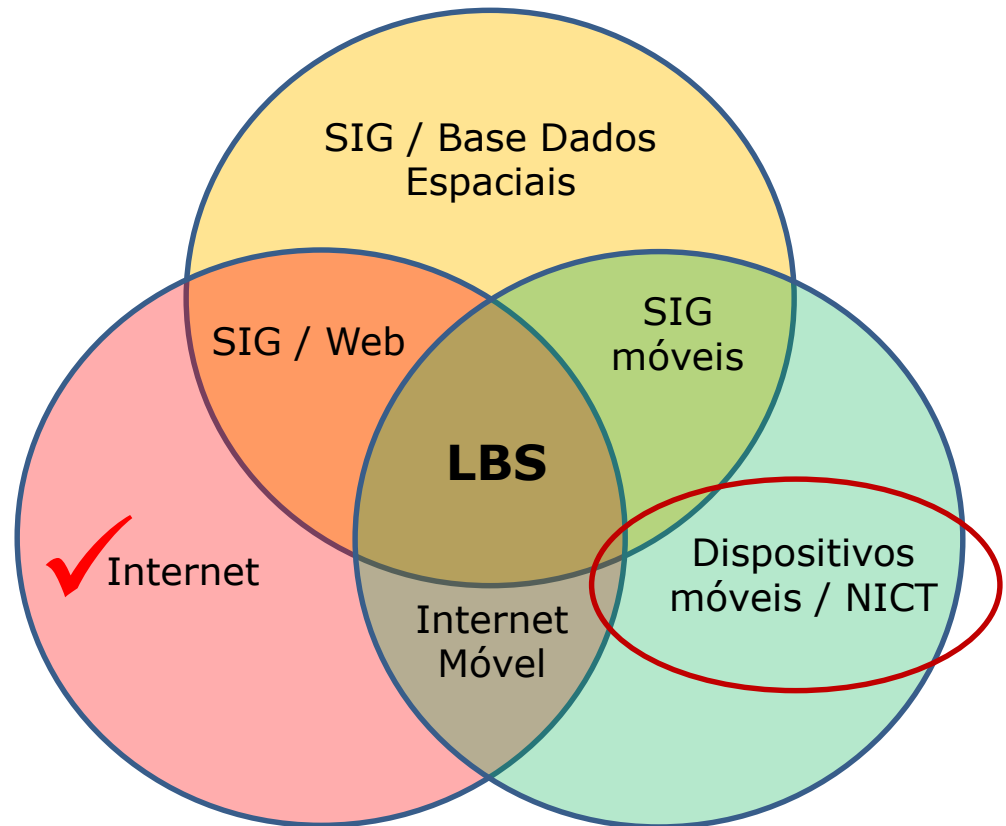



## LBS Research Agenda is online

Posted on [September 13, 2018](#) by [Haosheng Huang](#)

The [ICA Commission on Location Based Services](#) is happy to announce that the LBS Research Agenda has been published online as an open access paper in the Journal of Location Based Services. For more details, please refer to <https://lbs.icaci.org/research-agenda/>.

### ▪ [LBS Research Agenda](#)

*Haosheng Huang, Georg Gartner, Jukka M. Krisp, Martin Raubal & Nico Van de Weghe (2018): [Location based services: ongoing evolution and research agenda](#), Journal of Location Based Services, DOI: 10.1080/17489725.2018.1508763*

A [multi-phase collaborative process](#) was adopted during the development of this research agenda: Based on the [31 one-paragraph proposals](#) of “big challenges in LBS”, and the feedback and results of the [workshop at LBS 2016](#) and conference session at [ICC 2017](#), we identified a list of “key research challenges” that should be addressed to bring LBS to a higher level to better benefit our society and environment. Thank you to all the participants during this process!

The current research agenda highlights a series of research challenges in six broad areas: “Ubiquitous positioning”, “Context modelling and context-awareness”, “Mobile user Interfaces and interaction”, “Analysis of LBS-generated data”, “User studies and evaluation”, and “Social and behavioural implication of LBS”. As the research agenda is

### RECENT POSTS

- [LBS Research Agenda is online](#) September 13, 2018
- [LBS 2018: Deadline extended to 23 July](#) July 11, 2017
- [2nd Call for Papers: LBS 2018, Zurich, Switzerland](#) June 15, 2017

### ARCHIVES

- [September 2018](#)
- [July 2017](#)
- [June 2017](#)
- [March 2017](#)
- [February 2017](#)
- [November 2016](#)
- [September 2016](#)
- [July 2016](#)
- [May 2016](#)
- [February 2016](#)
- [November 2015](#)
- [October 2015](#)
- [September 2015](#)





## Location based services: ongoing evolution and research agenda

Haosheng Huang <sup>a</sup>, Georg Gartner <sup>b</sup>, Jukka M. Krisp<sup>c</sup>, Martin Raubal<sup>d</sup>  
and Nico Van de Weghe <sup>e</sup>

<sup>a</sup>GIScience Center, Department of Geography, University of Zurich, Zurich, Switzerland; <sup>b</sup>Research Group Cartography, Department of Geodesy and Geoinformation, TU Wien, Vienna, Austria; <sup>c</sup>Research Group Applied Geoinformatics, University of Augsburg, Augsburg, Germany; <sup>d</sup>Institute of Cartography and Geoinformation, ETH Zurich, Zurich, Switzerland; <sup>e</sup>Department of Geography, Ghent University, Ghent, Belgium

### ABSTRACT

We are now living in a mobile information era, which is fundamentally changing science and society. Location Based Services (LBS), which deliver information depending on the location of the (mobile) device and user, play a key role in this mobile information era. This article first reviews the ongoing evolution and research trends of the scientific field of LBS in the past years. To motivate further LBS research and stimulate collective efforts, this article then presents a series of key research challenges that are essential to advance the development of LBS, setting a research agenda for LBS to 'positively' shape the future of our mobile information society. These research challenges cover issues related to the core of LBS development (e.g. positioning, modelling, and communication), evaluation, and analysis of LBS-generated data, as well as social, ethical, and behavioural issues that rise as LBS enter into people's daily lives.

### ARTICLE HISTORY

Received 4 April 2018  
Accepted 18 July 2018

### KEYWORDS

Location based services;  
research trends; research  
agenda; mobile devices;  
context-aware computing

## 1. Introduction

While the first location based services (LBS) appeared in the early 1990s (e.g. ActiveBadge), LBS became a fast-developing research field only in the early 2000s, mainly due to the discontinuation of the selective availability<sup>1</sup> of Global Positioning System (GPS) by the U.S. President Bill Clinton in May 2000. This discontinuation has made GPS more responsive to civil and commercial users worldwide. Since that time, more and more GPS-based applications have appeared, resulting in a strong interest in LBS from both academics and industry. LBS can be defined as computer applications (especially mobile computing applications) that deliver information tailored to the location and context of the device and the user (Raper et al. 2007a; Brimicombe and Chao 2009). In 2007, Raper et al. (2007a, 2007b) provided a state-of-the-art review of the research field of LBS, and outlined several research challenges. Since then, there have been many changes in the field. First, recent years have witnessed rapid advances in its enabling technology, such as mobile devices and telecommunication. Second, there has been an increasing demand in expanding LBS





## Call for Participation: LBS 2019, 11-13 November 2019, Vienna, Austria

*The ICA Commission on Location Based Services and Technische Universität Wien are pleased to invite you to the 15th International Conference on Location Based Services (LBS 2019), which will take place in Vienna on November 11-13, 2019.*

The peer-reviewing process has been completed, and we have selected a list of interesting oral presentations for LBS 2019, which can be found at <https://lbsconference.org/>. A list of

**LBS 2019**  
15<sup>th</sup> Conference on Location Based Services  
Vienna, 11–13 November 2019

### Search

### About ICA

The mission of the International Cartographic Association (ICA) is to promote the disciplines and professions of cartography and GIScience in an international context.

- **9:00-9:20 Conference opening** (Rector Prof. Sabine Seidler, Prof. Georg Gartner, Dr. Haosheng Huang)
- **9:20-10:00 Keynote** by Prof. Ioannis Giannopoulos (TU Wien): Eye Tracking, Machine Learning and Augmented Reality for LBS – Emerging Technologies and Research Methods
- **10:00-10:45 Session 1 (Mobile Cartography)**
  - Sven Gedicke, Benjamin Niedermann and Jan-Henrik Haunert: Multi-page Labeling of Small-screen Maps with a Graph-coloring Approach (25')
  - Silvia Klettner: Small Symbols With Big Effect? – A Cognitive-Affective Perspective on Map Symbolization on Small-Sized Displays (20')
- **10:45-11:15 Coffee break**
- **11:15-12:20 Session 2 (Navigation and Wayfinding I)**
  - Jelle De Bock and Steven Verstockt: SmarterRoutes – A data-driven and context-aware methodology for level-of-detail adaptation of navigation services (25')
  - Laure De Cock, Kristien Ooms, Nico Van de Weghe and Philippe De Maeyer: Adapting the Type of Indoor Route Instruction to the Decision Point (20')
  - Marina Georgati and Carsten Kessler: A 3D Routing Service for Indoor Environments (20')

# New Information and Communication Technologies

New Information and Communication Technologies (NICT) refers to emerging information and communication technologies with an emphasis on mobility and location awareness

This includes

Technologies related to mobile telecommunications networks (wireless)

Other wireless networks

Small mobile wireless devices (Tablets, mobile phones)

Positioning technologies, particularly those that integrate mobile devices

# Telecomunicações Móveis sem fios

A primeira comunicação sem fios foi efectuada em 1903 e foi realizada por Guglielmo Marconi. Foi um telegrama enviado pelo Presidente dos EUA (Theodore Roosevelt) para o Rei de Inglaterra (Eduardo VII)

O primeiro serviço público de telefone móvel foi introduzido nos Estados Unidos após a segunda guerra mundial.

**Em 1968**, a AT&T propôs o conceito de Sistema móvel Celular à US Federal Communications Commission (FCC).

**Em 1983**, a FCC finalmente aloca 666 canais duplos para o Advanced Mobile Phone System (AMPS). Todos os sistemas são analógicos com a tecnologia simples de FM (Frequência Modulada)

# Mobile Telecommunications

---

No final dos anos 1980, foi instalado o primeiro sistema digital nas principais cidades dos EUA (US Digital Celular).

Um sistema celular baseado no CDMA (Code Division Multiple Access, que falaremos a seguir) foi desenvolvido pela Qualcomm Inc. e normalizada pela Telecommunications Industry Association (TIA) como uma norma "Interim" (Interim Standard, IS-95).

Na Europa os sistemas analógicos (E-TACS) evoluíram para o digital (**GSM** – Global System for Mobile).

Os sistemas analógicos são referidos como de primeira geração (1G) e a segunda geração 2G é referida à primeira geração dos sistemas digitais



# Wireless Mobile Telecommunication Networks, Basic Concept

O conceito base de uma rede móvel sem fios é uma rede de células

Em cada célula existe uma **Base Transceiver Station** (BTS) contendo equipamento de transmissão e recepção de sinal rádio.

Uma BTS estabelece comunicação com telefones móveis no interior da célula.

A BTS é também conhecida como **Base Station** (BS), consiste em:  
Antenas, amplificador, receptor, transmissor, hardware e software para comunicação do sinal.



A cobertura de uma célula depende de diversos factores como a potência de transmissão da BS e do telefone móvel, a altura das antenas na BS e a topografia da célula



# Conceito Básico de WMTN



Ilustração do principio básico de uma rede móvel sem fios

# Celular Concept

A mobile network is usually represented by hexagons as BS approximation of circular coverage areas.

Each hexagon is a cell that is given a unique identifier - **Cell-ID**

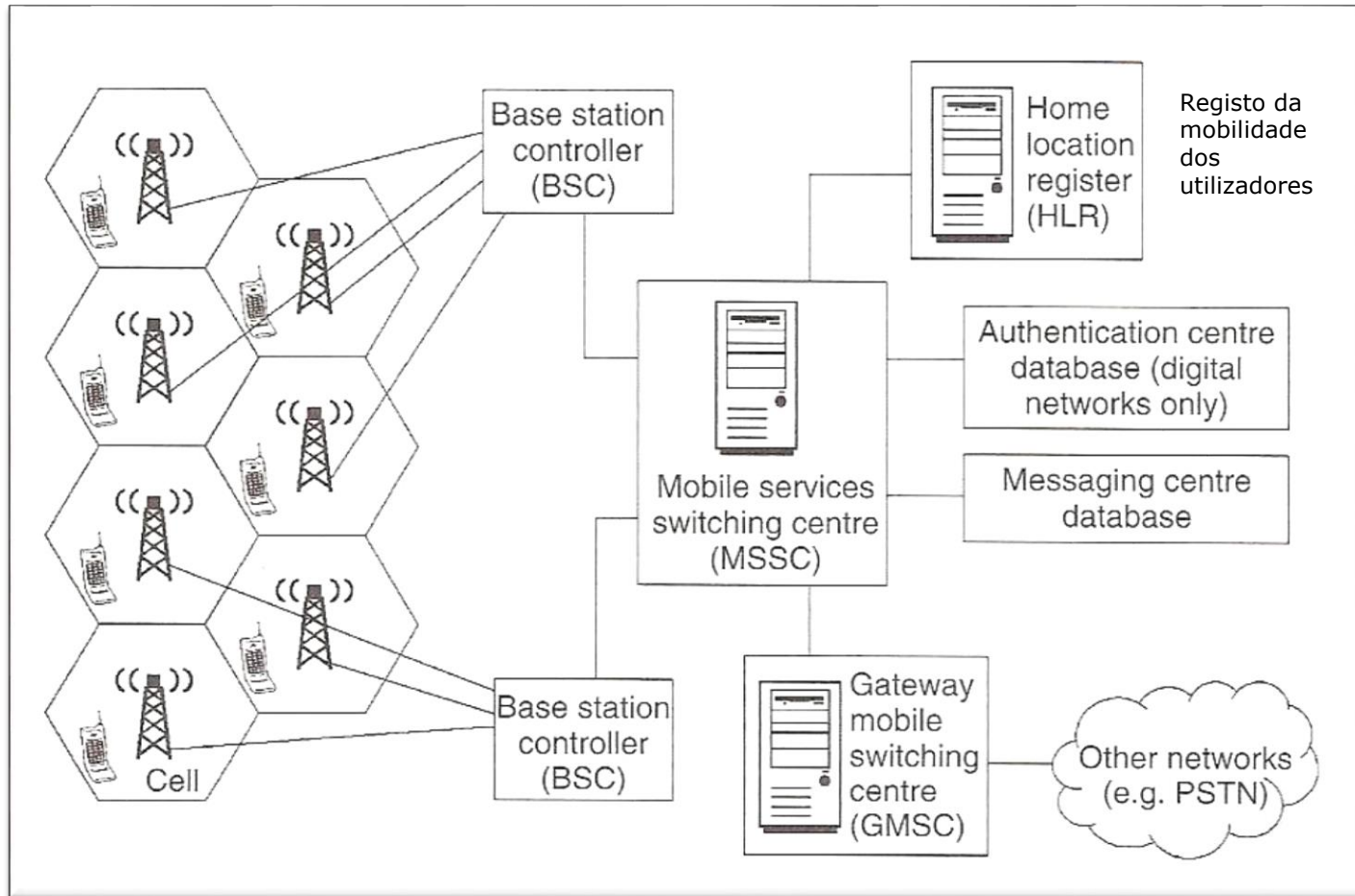
When a mobile phone is within range of a BS, it is registered to the cell of that BS. Each cell uses different radio frequencies to reduce possible interference with adjacent cells.

When a user moves from one area to another, logging and ongoing calls are managed so that there is no interruption in the passage between cells.

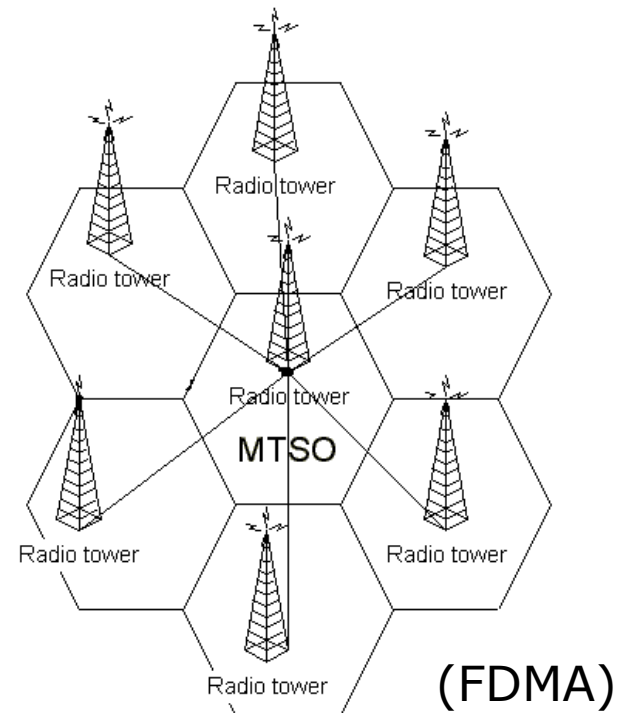

# Mobile Network generations

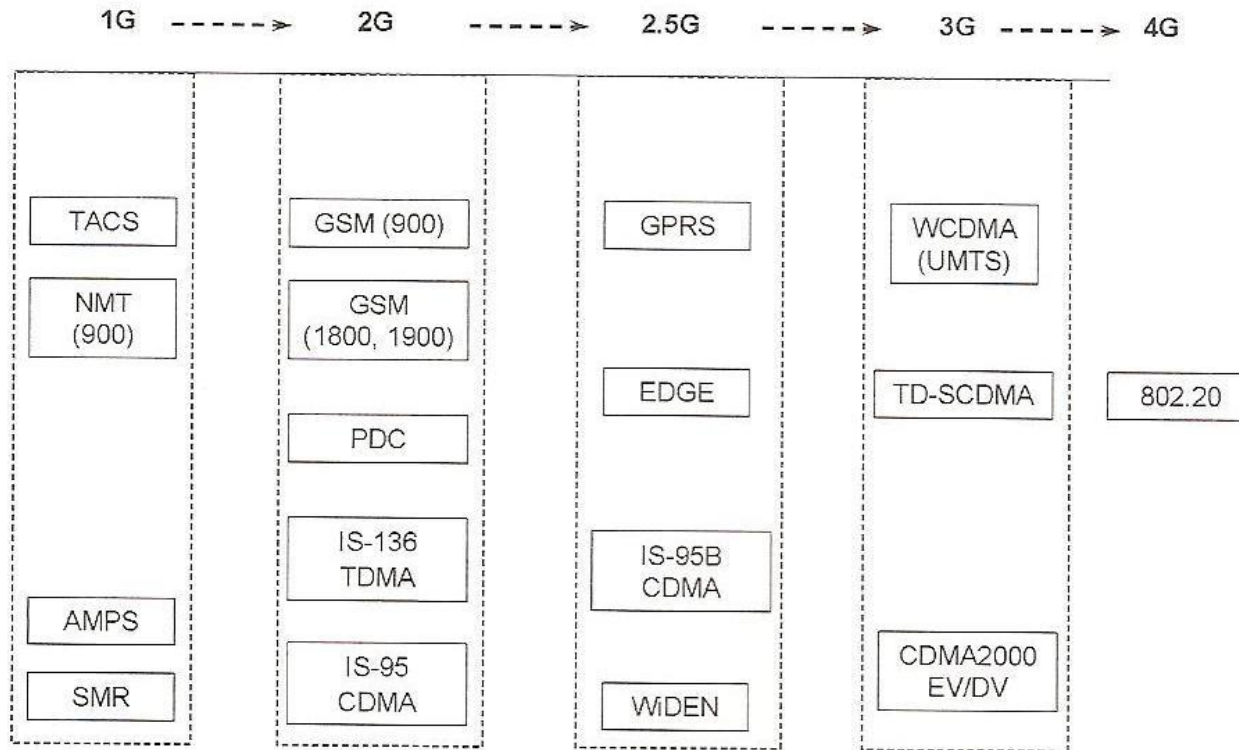

Desde o início das redes móveis em 1970 até hoje as redes móveis foram evoluindo desde a primeira geração 1G até à actual 3G e 4G.

# Primeira Geração 1G

As primeiras redes móveis eram analógicas

Funcionavam na banda de frequências 800-960 MHz com taxas de transferência de dados até 9.6 kbps.

A tecnologia era a Frequência Modulada (FM) e a Frequency Division Multiple Access (FDMA) (conceito celular)

**Sistemas** : AMPS ( Advanced Mobile Phone System) desenvolvido na America do Norte  
TACS (Total-Access Communication System) desenvolvido no Reino Unido  
NMT (Nordisk Mobile Telefoni) desenvolvido na Europa do Norte

**Limitações:** degradação do sinal com a morfologia do terreno, condições meteorológicas e volume de tráfego.  
Pouco seguras as comunicações, facilmente interceptadas

# Segunda Geração (2G)

A segunda geração é digital (introduzida no início de 1990)

Norma **GSM** (Global System for Mobile) introduzida na Finlândia

## Vantagens sobre a rede 1G:

- Aumento da capacidade resultante do aumento (3x) da eficiência de uso do espectro
- Redução nos custos da infra-estrutura e nos custos por subscritor
- Redução da fraude com mais segurança com vários níveis de encriptação
- O serviço principal é a comunicação por voz
- Suporta ainda SMS (Short Message Service) e MMS (Multimedia Message Services)
- Transferência de dados entre 9.6 e 28 kbps

# Características do GSM

## Global System for Mobile Communications

The first objective of this system was the interoperability, universal use, crossing borders. It uses circuit-switched technology.

GSM has a bandwidth of 200KHz and uses several frequencies: 900, 1800 and 1900 MHz. The system consists of three components:

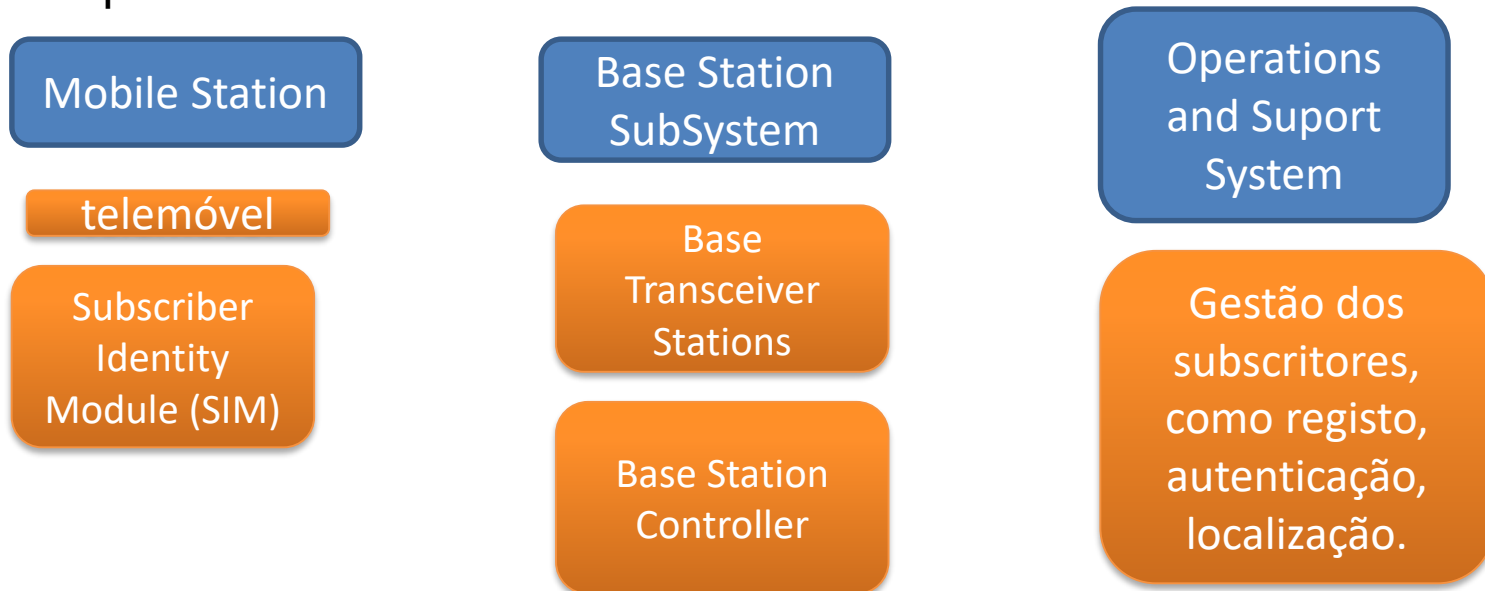



# Características do GSM

---

O sistema GSM 900 utiliza dois conjuntos de frequências na banda dos 900 MHz:

1. De 890-915MHz, utilizado para as transmissões do terminal
2. De 935-960MHz, para as transmissões da rede.

O método utilizado pelo GSM para gerir as frequências é uma combinação de duas tecnologias:

**FDMA (*Frequency Division Multiple Access*)** e  
**TDMA (*Time Division Multiple Access*)**

O FDMA divide os 16 MHz disponíveis de frequência em 80 canais com uma largura de 200 kHz e uma capacidade de transmissão de dados na ordem dos 270 Kbps. Uma ou mais destas frequências é atribuída a cada estação-base e dividida novamente, em termos de tempo, utilizando o TDMA, em oito espaços de tempo (*timeslots*).

# Conceito de reutilização de frequência

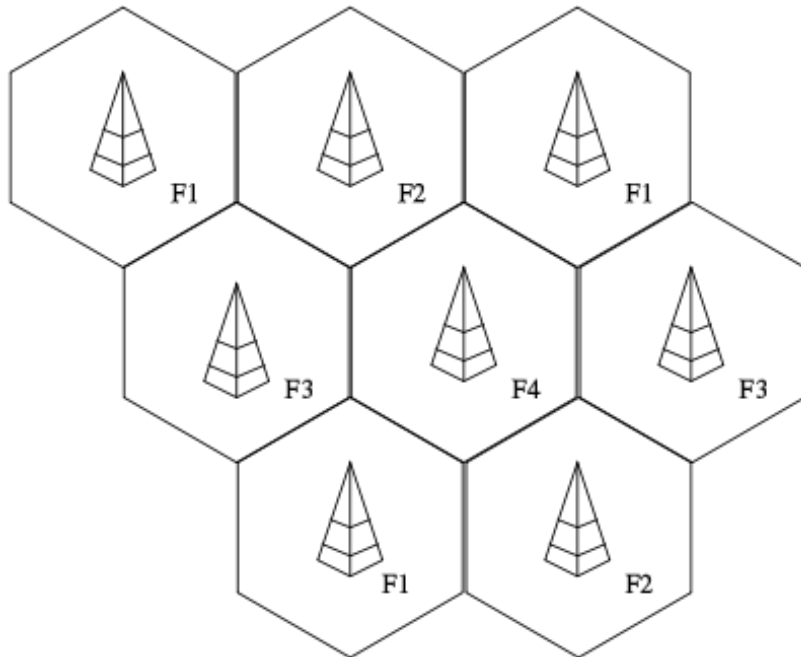

## Frequency Division Multiple Access (FDMA)

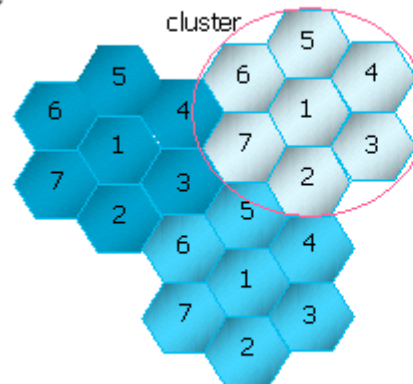

Ideal hexagonal grid (N=7)

- Tessellations of hexagonal cells require  $N=i^2+ij+j^2$ , where  $i \geq j \geq 0$  are integers  
= 1, 3, 4, 7, 9, 12, 13, 16, 19...
- Used in FDMA & TDMA based systems
  - Not required in CDMA which has universal frequency reuse
- Cells idealized as hexagons
  - Not appropriate for microcells, highways etc.

Um dos elementos fundamentais nas redes móveis sem fios é o conceito e implementação da reutilização de frequência, também conhecido como conceito celular.

# Conceito de reutilização de frequência

---

O princípio da reutilização da frequência é o processo no qual as frequências (canais) alocados a uma célula são reutilizadas noutras células distantes sem interferência. Isto aumenta a capacidade para cada área geográfica, dadas as limitações no uso de frequências, sem a necessidade de grandes mudanças tecnológicas. O conceito de reutilização de frequências é visto como a chave para evitar congestionamentos da rede. O conceito básico da reutilização de frequências é instalar um número de pequenas células com transmissores de pequena potencia em substituição de grandes células com transmissores de grande potencia.

A BS de cada célula é alocada uma porção dos canais disponíveis para toda a rede. Às BS adjacentes são atribuídos canais diferentes. Assim, a interferência entre BS adjacentes e os utilizadores móveis é minimizada.

As BS e os seus canais podem ser sistematicamente localizados e os canais disponíveis podem ser distribuídos por regiões geográficas. Consequentemente, os canais disponíveis podem ser reutilizados muitas vezes, permitindo que o nível de interferência entre BSs com os mesmos canais seja suficientemente baixo.



# Frequências atribuídas à Vodafone

Cada canal tem  
200 kHz

Nº CANAL	Emissão de Estações Móveis (MHz)	Emissão de Estações de Base (MHz)
1	890,2	935,2
2	890,4	935,4
3	890,6	935,6
4	890,8	935,8
5	891,0	936,0
6	891,2	936,2
7	891,4	936,4
8	891,6	936,6
9	891,8	936,8
10	892,0	937,0
11	892,2	937,2
12	892,4	937,4
13	892,6	937,6
14	892,8	937,8
		938,0
		938,2
		938,4

79 canais \* 0.2 MHz = 15.8 MHz  
 890MHz + 16 MHz = 906 MHz (inicio da TMN)  
 906MHz + 16 MHz = 922 MHz (inicio da Zon??)

# Frequências atribuídas à Meo

6° 1. As frequências respeitantes aos canais atribuídos para a tecnologia digital - GSM são as seguintes:<sup>5</sup>

N° DE CANAL	FREQUÊNCIA CENTRAL (MHz)	
80	906,0	951,0
81	906,2	951,2
82	906,4	951,4
83	906,6	951,6
84	906,8	951,8
85	907,0	952,0
86	907,2	952,2
87	907,4	952,4
88	907,6	952,6
89	907,8	952,8
90	908,0	953,0
91	908,2	953,2
92	908,4	953,4
93	908,6	953,6
94	908,8	953,8
95	909,0	954,0
96	909,2	954,2



# QUADRO NACIONAL DE ATRIBUIÇÃO DE FREQUÊNCIAS - ANACOM

FAIXA DE FREQUÊNCIAS (MHz)	ATRIBUIÇÕES DO REGULAMENTO DAS RADIOCOMUNICAÇÕES – ARTº 5 – APLICÁVEIS A PORTUGAL	PRINCIPAIS APLICAÇÕES NACIONAIS	NOTAS
1215 - 1240	EXPLORAÇÃO DA TERRA POR SATÉLITE (activo)  RADIOLOCALIZAÇÃO  RADIONAVEGAÇÃO POR SATÉLITE (espaço-Terra) 5.329, 5.329A (espaço-espaço) 5.328B  INVESTIGAÇÃO ESPACIAL (activo)  RADIONAVEGAÇÃO 5.331  5.332	GPS – Sistema Global de Posicionamento (RVA-S)	
1240 – 1300	EXPLORAÇÃO DA TERRA POR SATÉLITE (activo)  RADIOLOCALIZAÇÃO  RADIONAVEGAÇÃO POR SATÉLITE (espaço-Terra) 5.329, 5.329A (espaço-espaço), 5.328B	Radares de perfil de vento	

A técnica **Time Division Multiple Access** divide o espectro radio em slots temporais para aumentar a capacidade.

Em cada slot temporal só um utilizador pode emitir ou receber.

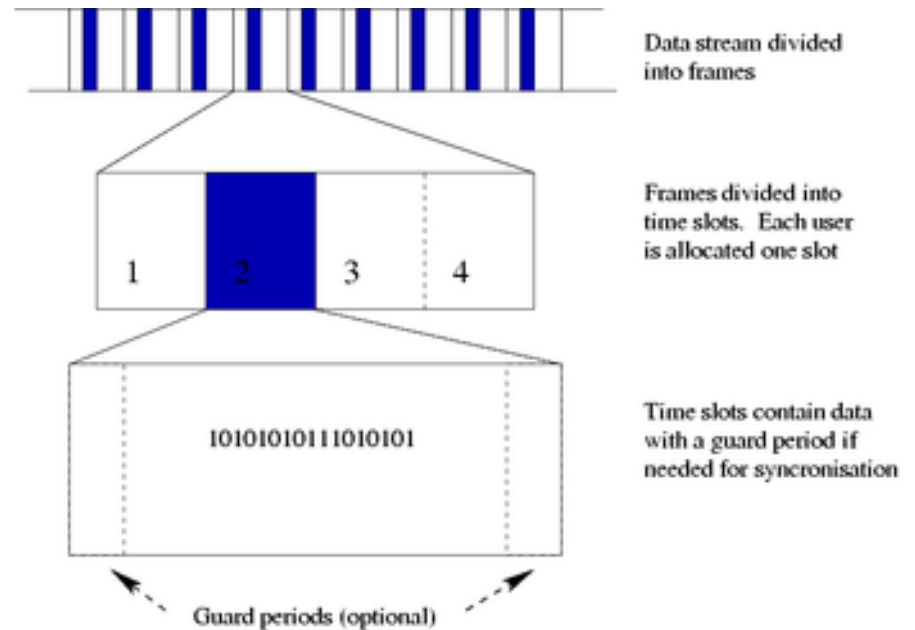

No caso das redes GSM, os 200KHz de espectro são divididos em 8 slots temporais (tb referidas como canais). A cada utilizador é alocado um canal transmitindo voz ou dados. Os vários utilizadores transmitem numa rápida sucessão, cada um usando o seu slot, permitindo uma comunicação contínua porque o processo é muito rápido.

The terminal uses a timeslot for reception and another for issuance.

They are temporally separated so that the phone is not receiving and transmitting at the same time. This time division is also called full rate.

The voice is encoded in a complex way so that transmission errors can be detected and corrected. Next, the digital voice coding is sent in the timeslots, each with a duration of 577 milliseconds and a capacity of 116 coded bits.

**GSM networks are circuit-switched** (two nodes establish a connection for communication at the time of communication, this circuit must be established before voice communication can begin)

The network user has a Subscriber Identity Module (SIM) card that identifies them in their network and in other networks.

# Redes 2.5G

---

Estas redes são um passo intermédio para a geração 3G.

A norma que representa a tecnologia 2.5G funciona no equipamento 2G e o software é modificado e actualizado para suportar maiores taxas de transmissão.

A tecnologia 2.5G tem uma extensão “**packet-switched**” desenvolvida para as normas rádio moveis 2G.

Isto quer dizer que os dados são enviados em porções /pacotes (“packets”) e cada pacote é enviado completamente independente do outro.

Esta tecnologia tem como principal propósito o permitir o acesso rápido à Internet a partir dos dispositivos móveis

# Redes 2.5G

---

As redes 2.5G podem ter taxas de transmissão de 384kbps

As redes 2.5G **usam IP** para possibilitar um acesso rápido às redes de dados.

Suporta **WAP (Wireless Application Procol)** que permite o uso da Internet através de um dispositivo móvel e permite as páginas WEB serem desenhadas num formato comprimido propositadamente para dispositivos móveis com pequenos ecrãs.

Existem duas redes 2.5G principais:

- **GPRS** (General Packet Radio Service)
- **EDGE** (Enhanced Data Rates for GSM Evolution)

- ➔ It supports high transmission rates (between 144 Kbps and 2Mbps) enabling fast access to the Internet and multimedia applications such as video conferencing between mobile networks.
- ➔ The 3G initiative aims to define a set of specifications enabling interoperability between all country and region networks and products.
- ➔ The standard for 3G networks will be the Universal Mobile Telecommunication System (UMTS) also referred to as the Wideband CDMA (W-CDMA)
- ➔ The data rate on 3G networks is determined and influenced by various factors including the equipment and software on the mobile network, the speed with which the user moves and the distance to the nearest BS.



# CDMA, code division multiple access

---

Unlike competing systems, such as GSM, which uses TDMA, **CDMA** does not allocate a specific frequency to each user. Alternatively, each channel uses the full spectrum available.

Each user is assigned a pseudorandom keyword or spreading code that is used in a time correlation to separate between different user communications (see GPS PRN processing).

CDMA consistently provides better voice and data communications capabilities than any other commercial mobile technology, allowing more subscribers to communicate simultaneously.

**CDMA is the base platform for 3G technology.**

# Redes 4G ou LTE (Long Term evolution)

As principais características da rede 4G são:

- a) Elevada velocidade de transmissão de dados (100Mbps a 1Gbps)
- b) Elevada mobilidade
- c) Internet Protocol (IP) packet switched
- d) Rede integrada baseada num IP

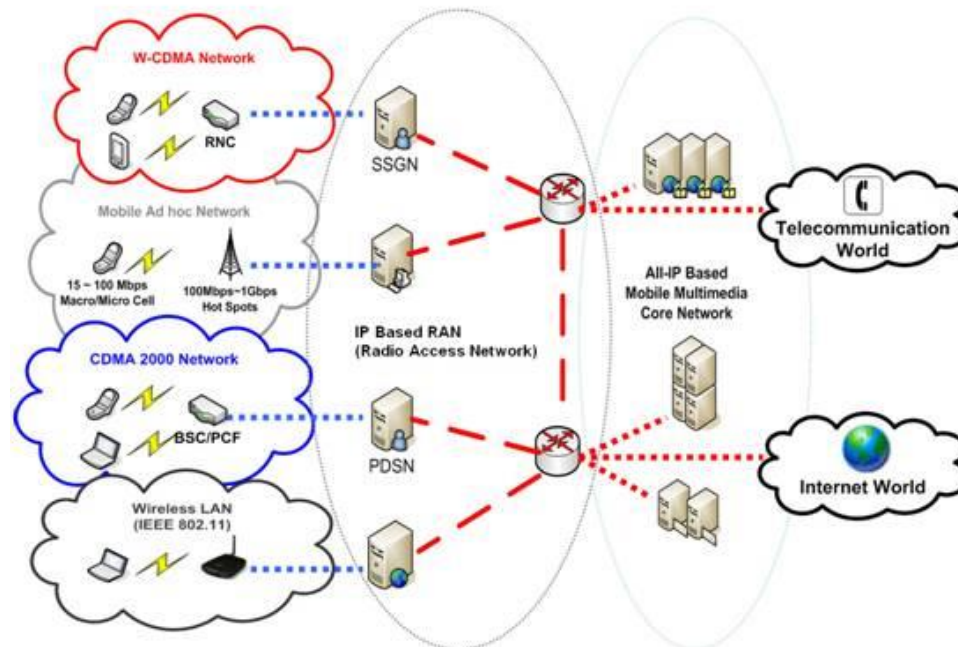

(embora o primeiro objectivo das redes 3G fosse o desenvolvimento de uma norma única, estão a ser desenvolvidas diversas normas, daí o aparecimento de uma 4G)

# Redes 4G ou LTE

## Frequências atribuídas para o 4G

### Portugal [ [edit](#) ]

All 3 mobile phone operators in Portugal (MEO, Vodafone and NOS) offer 4G internet services:

Frequency	E-UTRA Band	Bandwidth	Type of LTE	MEO	Vodafone	NOS
800 MHz	XX (20)	2x30 MHz	FDD	2x10 MHz	2x10 MHz	2x10 MHz
1800 MHz	III (3)	2x30 MHz	FDD	2x10 MHz	2x10 MHz	2x10 MHz
2600 MHz	VII (7) XXXVIII (38)	2x60 MHz	FDD	2x20 MHz	2x20 MHz	2x20 MHz

Leilão de atribuição das frequências:

<http://www.anacom.pt/render.jsp?categoryId=344561#.VINcPXbhDIU>

# Cobertura 2G, 3G e 4G

<https://opensignal.com/networks>

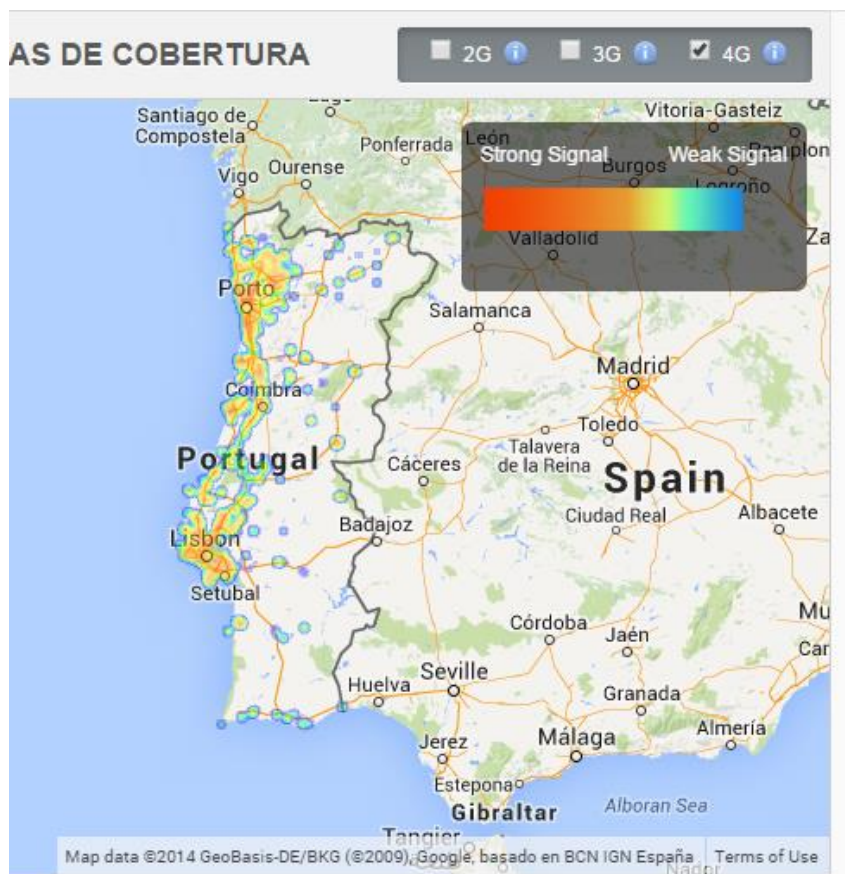

2014

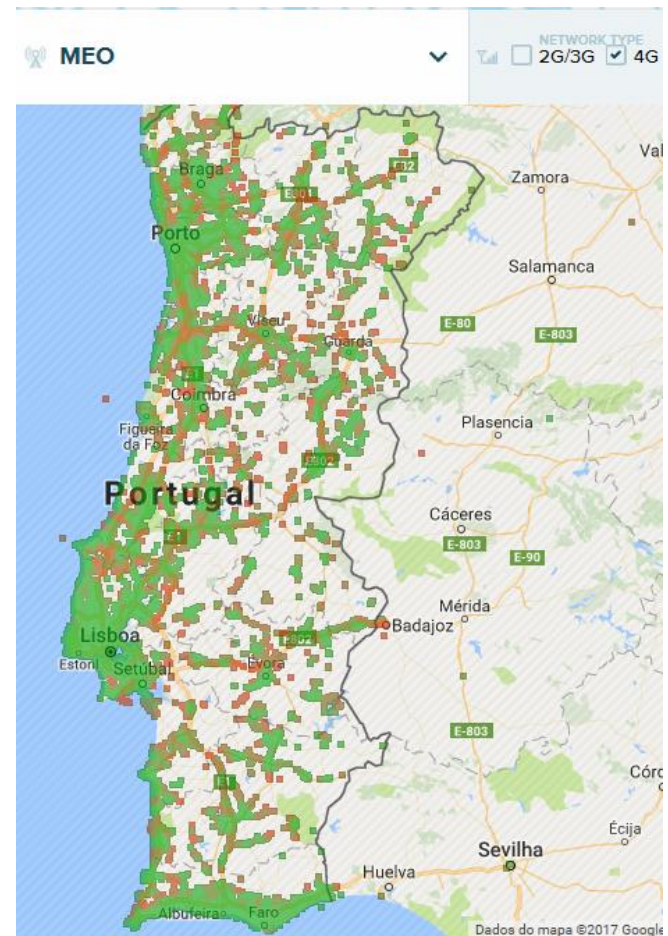

Maps updated on 19th Sep 2017

2017



## WHAT 5G WILL DO AND HOW IT COULD DO IT

### Data Rate

The maximum transmission data rate (gigabits per second) will be 20 times as fast as 4G LTE, while the average user will experience rates 10 to 100 times as fast.

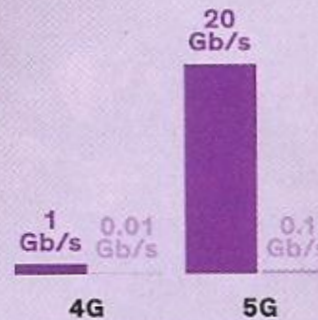

### Proposed Technologies

- Massive multiple-input, multiple-output (MIMO)
- Millimeter wavelength spectrum

### Spectral Efficiency

5G will improve downlink spectral efficiency (bits per second per hertz) threefold.

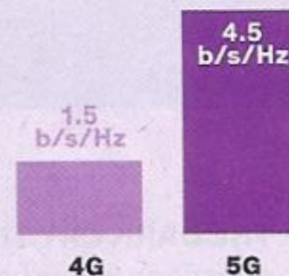

- Device-to-device (D2D) communication
- Full duplex system
- Massive MIMO

### Data Processing

The network will be able to process 100 times as much data in a given area (megabits per second per square meter).



- D2D
- Millimeter wavelength spectrum
- Radio-access network virtualization
- Small cells

LTE=Long-Term Evolution

## Device Density

About 900,000 more devices per square kilometer will be able to connect to the network.

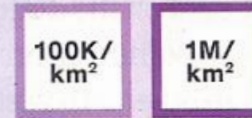

4G

5G

- D2D
- Small cells

## Mobility

4G can provide data to devices moving at up to 350 kilometers per hour.

5G will provide data to devices moving at up to 500 km/h.



4G

5G

- Heterogeneous network architectures

## Transmission Delay

5G will have one-tenth the latency (milliseconds) of 4G



- D2D
- Content caching close to users

## Energy

4G takes 1 millijoule to transfer a 1,000-bit data packet.

5G will be able to transfer packets 100 times as efficiently

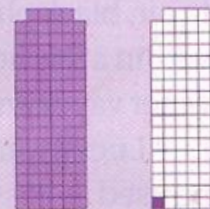

4G

5G

- Massive MIMO





## ENRICO SALVATORI

### Europe pushes forward on 5G and multi-constellation GNSS

Enrico Salvatori, leader of semiconductor and telecommunications giant Qualcomm's European effort, explains how his company is leveraging multiple GNSS constellations, including Europe's recently launched Galileo, to create a broad range of powerful modem and application processor portfolios.

**M**ultinational semiconductor and telecommunications company Qualcomm is a world leader in the design and marketing of 3G, 4G and next-generation wireless technologies. Headquartered in San Diego, California, Qualcomm has been widening its footprint in the Europe, Middle East and Africa (EMEA) region, with a core focus in

band (MBB), massive Internet of Things (IoT) and mission-critical services, in line with the European Commission's 5G Action Plan."

The Commission, which is the executive arm of the EU, has been actively promoting very high-capacity

networks such as 5G as Europe works to keep pace in the global wireless technologies market, citing expected worldwide 5G revenues for mobile operators in the region of €225 billion per year by 2025 (about 270 billion USD).

Salvatori said Qualcomm is proud to have established a long-lasting partnership with the European Commission (EC) and, as it happens, with the European GNSS Agency (GSA), sharing that agency's central goal of bringing Europe's global satellite navigation program, "Galileo," to full fruition.

"Here at Qualcomm," Salvatori said, "we are pursuing ongoing work on various IoT verticals, including LTE MTC/NB-IOT and in particular C-V2X. And

the Europe, Middle East and Africa (EMEA) region, with a core focus in Europe.

“We expect to grow Qualcomm’s presence in Europe, becoming a major EU (European Union) player in the digitization of European industries,” said Qualcomm senior vice president and president of Qualcomm Europe, Enrico Salvatori.

Part of that growth entails the company’s recently announced acquisition of Dutch-based NXP Semiconductors, a leading supplier for the secure identification, automotive and digital networking industries, a deal expected to be sealed by the end of calendar year 2017.

## Key European Considerations

“Accurate, reliable, and rapid position location is an important part of the mobile experience,” Salvatori said. “We are currently continuing 5G standardization in 3GPP under an accelerated timeline, which will ultimately achieve results for all use cases for extreme mobile broad-

## Things you should know

**3GPP**—Third Generation Partnership Project, a collaboration between groups of telecommunications associations, known as the Organizational Partners.

**LTE**—Long Term Evolution, applying to the idea of improving wireless broadband speeds to meet increasing demand.

**MTC**—Machine Type Communication, also known as machine-to-machine communication, i.e. direct communication between devices.

**NB-IOT**—Narrow-Band Internet of Things, a Low-Power Wide-Area Network radio technology standard enabling a range of devices and services to be connected using cellular telecommunications bands.

**C-V2X**—Cellular Vehicle to Everything, combining features of V2V (Vehicle to Vehicle), V2I (Vehicle to Infrastructure), V2P (Vehicle to Pedestrian) and V2N (Vehicle to Network).

**LTE Release 14**—3GPP standards are structured as Releases. Discussion of 3GPP thus frequently refers to the functionality in one release or another.

**NR**—5G New Radio, aimed at bringing fiber-like performance to wireless broadband at a significantly lower cost per bit.

**UMTS**—Universal Mobile Telecommunications System, a third-generation mobile cellular system for networks based on the GSM standard.

**HSPA**—High Speed Packet Access commonly refers to UMTS-based 3G networks that support specialized data for improved download and upload speeds.

## Low Investment, High Benefits

Salvatori said bringing Galileo into Qualcomm's already broad location services platform presented no particular technical issues. "Supporting

a new GNSS constellation does require some R&D," he said, "but we had already implemented support for other GNSS constellations like GPS, GLONASS and BeiDou.

"For us, Galileo's introduction in the

## R&D forefront

QUALCOMM IS CURRENTLY LEADING THE "CONVEX"

CONSORTIUM, which also includes Audi, Ericsson, Swarco Traffic Systems and the University of Kaiserslautern. The group's aim is to set up a test bed for first LTE Rel. 14 trials for V2X and to validate performance and feasibility.

The project combines techniques for vehicle-to-vehicle (V2V), vehicle-to-infrastructure (V2I), vehicle-to-person, (V2P), and vehicle-to-network (V2N) communications, which are considered key components for the implementation of advanced driving assistance systems and for automated driving.

The project is funded by the German Ministry of Transport and Digital Infrastructure (BMVI) in the program "Automated and Connected Driving on Digital Test Fields in Germany."

market at commercial scale promises more innovation and business models for the expanded connectivity needs of



# 2017 GSA Market Report

## Your key to GNSS market success

An insider look at market opportunities and technology trends across eight GNSS market segments, the GSA's 2017 GNSS Market Report is your key to successfully navigating this exciting market.

- The global GNSS market is expected to grow to an estimated **8 billion devices** by 2020.
- The GNSS downstream market is expected to produce over **€70 billion in revenue** annually, which could **more than double** when revenue from added-value services is included.
- In 2015-2020, the global core GNSS downstream market is forecast to grow by over **6 %** annually.
- By 2025, the installed base of GNSS devices in drones will reach **70 million**.



Download it now

[www.gsa.europa.eu/2017-](http://www.gsa.europa.eu/2017-)



# Outras Redes Wireless

## Wireless Local Area Networks (WLAN)

### Bluetooth

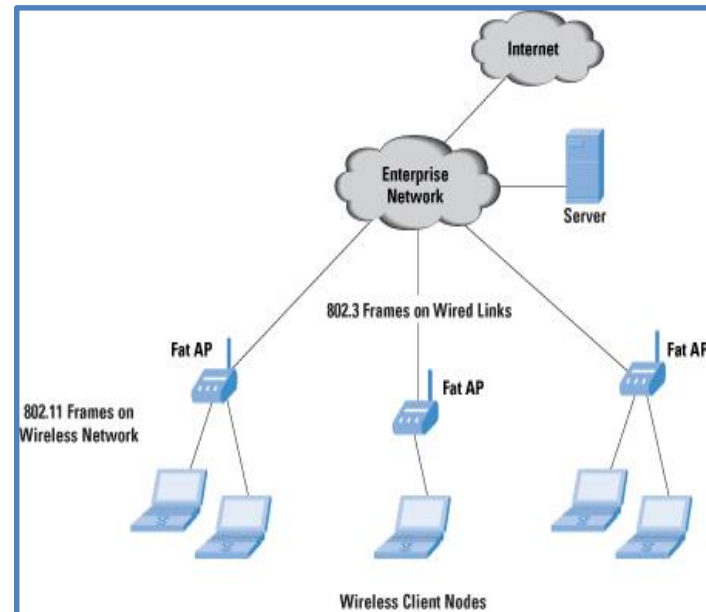
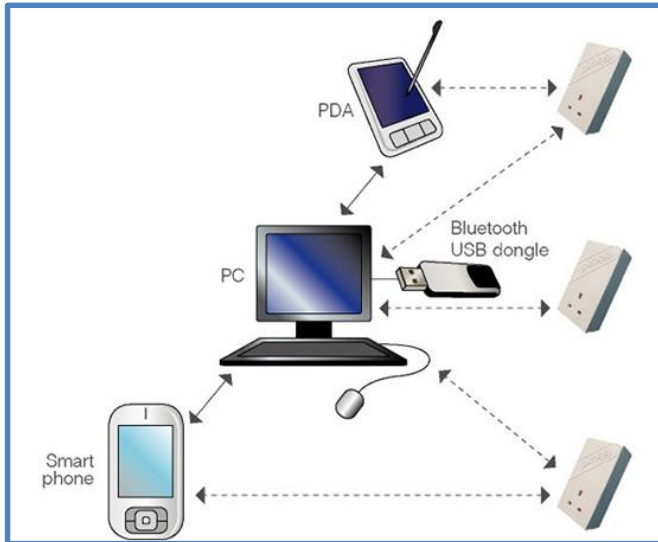

Não requerem uma licença para o uso do espectro e dispõem uma elevada taxa de transmissão de dados( 2,4 a 5,8 GHz)

# Wireless LANs

---

As WLANs são as redes sem fios usadas no interior de edifícios, para substituir os fios. O seu crescimento deveu-se sobretudo ao crescimento dos computadores portáteis.

O seu raio de acção é de cerca de poucas centenas de metros com uma velocidade de 11 a 54 Mbps.

O **WiFi (Wireless Fidelity)** é um conjunto de normas baseadas no protocolo de redes 802.11 do IEEE (Institute of Electrical and Electronic Engineers)

Um utilizador WiFi pode estar ligado enquanto se movimenta em áreas onde existam **Access Points (APs)**. Os Aps estão ligados fisicamente à rede com fios.

Ver página: [http://en.wikipedia.org/wiki/IEEE\\_802](http://en.wikipedia.org/wiki/IEEE_802)



**APs** (or routers) act as the base stations of mobile networks.

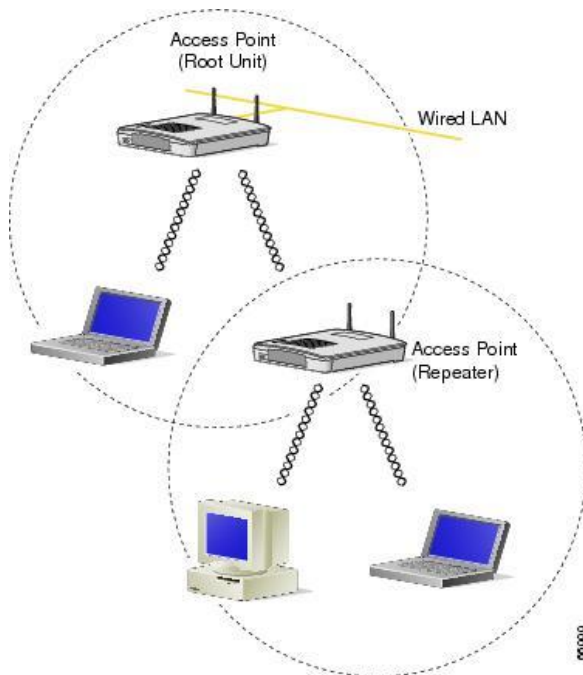

An AP has a radio transmitter, a receiver, and an interface with other networks (Ethernet or Internet).

APs are typically connected to a LAN, Ethernet-based LAN.

In a WiFi network devices (computer, TLM, Tablet) look for an AP by sending probe requests (existence) and receiving response from the nearest AP. The AP with the highest signal strength and lowest error rate is selected.

When the connection is established, packet data can be transmitted between the AP and the devices.





A rede da FCUL tem um unico router.

ver quais os canais em que funciona o wifi

[https://en.wikipedia.org/wiki/List\\_of\\_WLAN\\_channels](https://en.wikipedia.org/wiki/List_of_WLAN_channels)

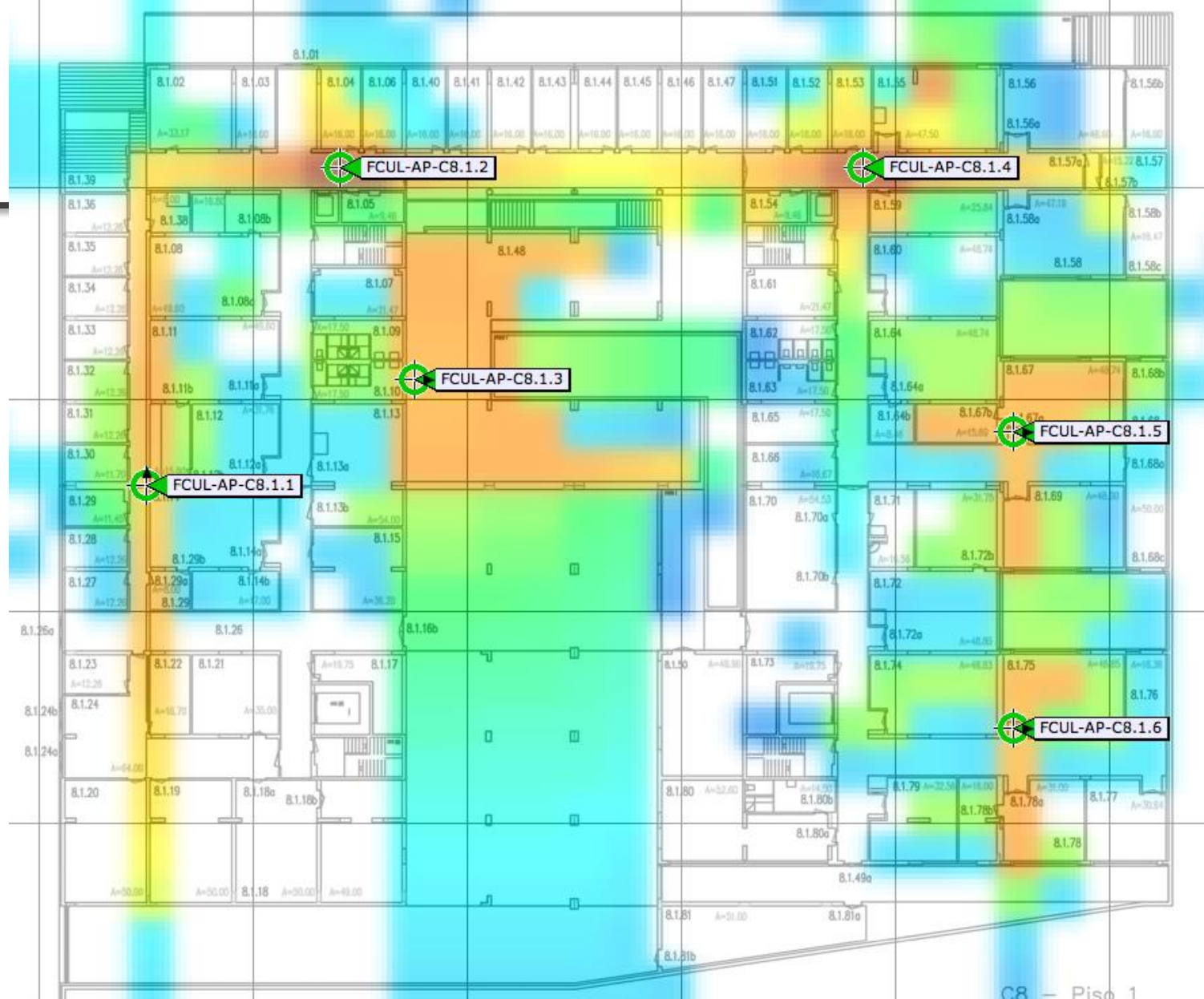

C8 - Piso 1

Distribuição dos APs no Piso 1 do C8

# Tecnologia Bluetooth

Enables ad-hoc wireless connection between two devices within 10 meters.

It was created by Ericsson Mobile Communications in 1994.

It is an open standard that operates globally in a 2.4 GHz radio frequency band. Data transmission is at a speed of 30-400 kbps.

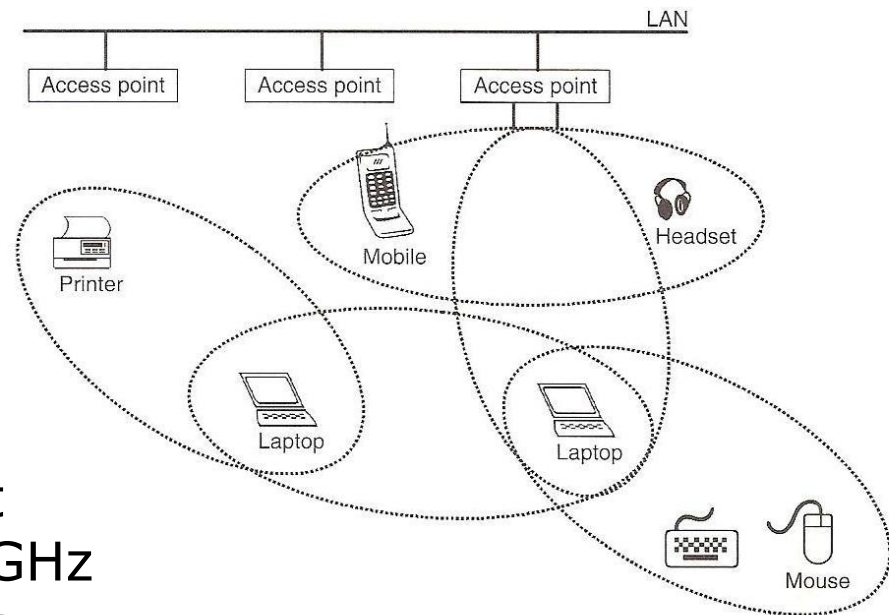

Bluetooth é o nome de um rei Harald Blatand, que unificou a Dinamarca e a Noruega no século X.

# Wireless Mobile Internet

---

The IP and TCP network protocols are designed for wired direct connection and almost error free connection. TCP was developed on the assumption that 99% of lost packets are caused by network congestion.



Protocols commonly used on the Internet, such as HTML, HTTP, and TCP, are insufficient on mobile networks when handling large data sets.



**WAP (Wireless Application Protocol)** is designed for mobile Internet services.

# Wireless Mobile Internet

O WAP é um conjunto de protocolos e serviços incluindo:

## **WTP (WAP Transaction Protocol)**

Protocolo de transação de níveis, equivalente ao TCP/IP desenvolvido para transacções “error-free” e “packet-loss”.

## **WTLS (Wireless Transport Layer Security)**

Transmissão de informação encriptada

## **WML (Wireless Markup Language)**

é uma versão light do HTML desenvolvido especialmente para a visualização de texto e gráficos em dispositivos móveis com um pequeno ecrã.

# Wireless Mobile Internet

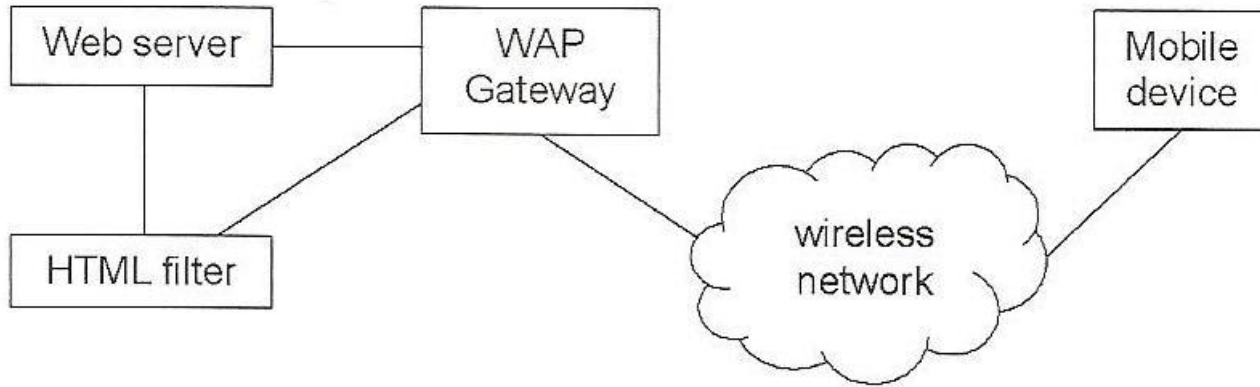

**WAP sites :** são sites Internet móvel desenvolvidos com WML e WMLscript (como JavaScript) permite a interactividade em pequenos dispositivos móveis

Outros sites Internet móvel podem ser dinamicamente convertidos para WML e acedidos via WAP browser

**WAP Gateway:** Servidor especial que melhora a eficiência da transferência do sinal entre a Internet e a rede sem fios.

Os pedidos e informação entre informação TCP/IP e os protocolos WAP são traduzidos na WAP Gateway



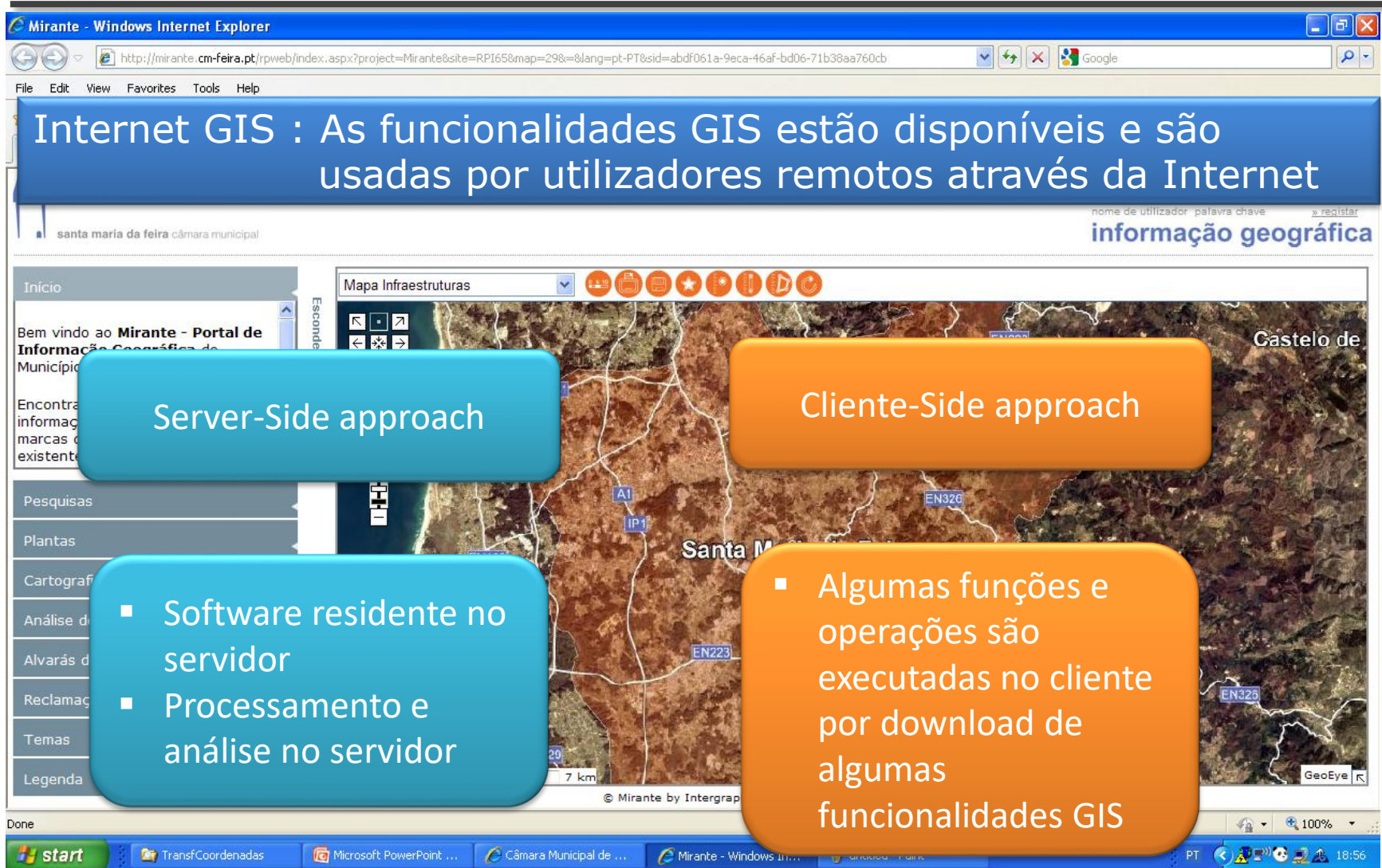

Mirante - Windows Internet Explorer

http://mirante.cm-feira.pt/rpweb/index.aspx?project=Mirante&site=RPI65&map=29&lang=pt-PT&sid=abd061a-9eca-46af-bd06-71b38aa760cb

File Edit View Favorites Tools Help

## Internet GIS : As funcionalidades GIS estão disponíveis e são usadas por utilizadores remotos através da Internet

santa maria da feira câmara municipal

nome de utilizador palavra chave > registar

### informação geográfica

Início

Bem vindo ao **Mirante - Portal de Informação Geográfica** do Município de Santa Maria da Feira

Encontra informação geográfica, mapas, marcas e existentes

Pesquisas

Plantas

Cartografia

Análise de

Alvarás de

Reclamações

Temas

Legenda

Mapa Infraestruturas

Server-Side approach

- Software residente no servidor
- Processamento e análise no servidor

Cliente-Side approach

- Algumas funções e operações são executadas no cliente por download de algumas funcionalidades GIS

Castelo de

Santa M

EN223

EN326

EN325

7 km

© Mirante by Intergrap

Done

start

TransfCoordenadas

Microsoft PowerPoint ...

Câmara Municipal de ...

Mirante - Windows I...

PT

18:56

# Wireless GIS

## Wireless Mobile GIS



## Mobile GIS

- Dados em tempo real
- Possibilidade de trocar, analisar informação espacial em tempo real
- Ainda problemas com taxas de transferência de dados

- Integrado com GPS já existe há vários anos
- Não está ligado à rede sem fios
- O software GIS está instalado nos dispositivos móveis



É a essência da convergência tecnológica, integra:

Telecomunicações móveis  
Hardware, Software  
Segurança, Dados  
Bases de dados

# Wireless GIS



As comunicações móveis são o elemento chave no Wireless GIS

Os dispositivos móveis devem ser dedicados a esta finalidade (baterias, capacidade processamento e qualidade do ecrã)

Algum software pode residir nos dispositivos móveis (ArcPad, GVSIG)

Os LBS são um conjunto de tecnologias heterogéneas:

- Os SIG e outras tecnologias espaciais
- A Internet e Web
- Novas Tecnologias de Informação e Comunicação (NICT)

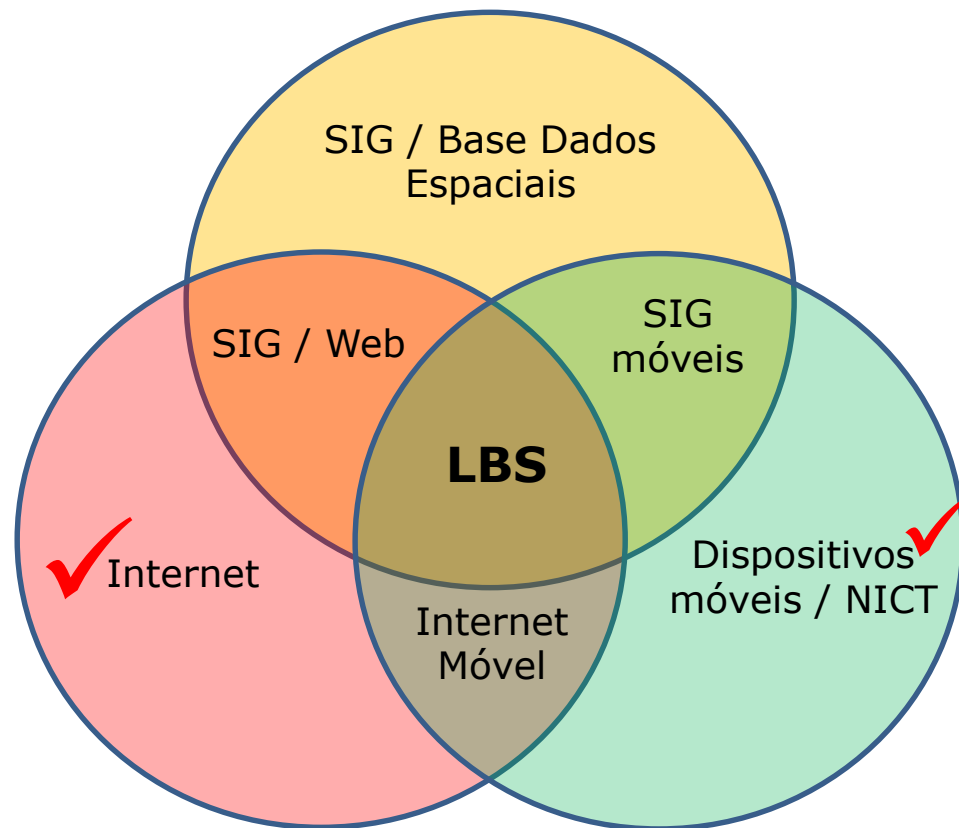

# Os Location Based Services

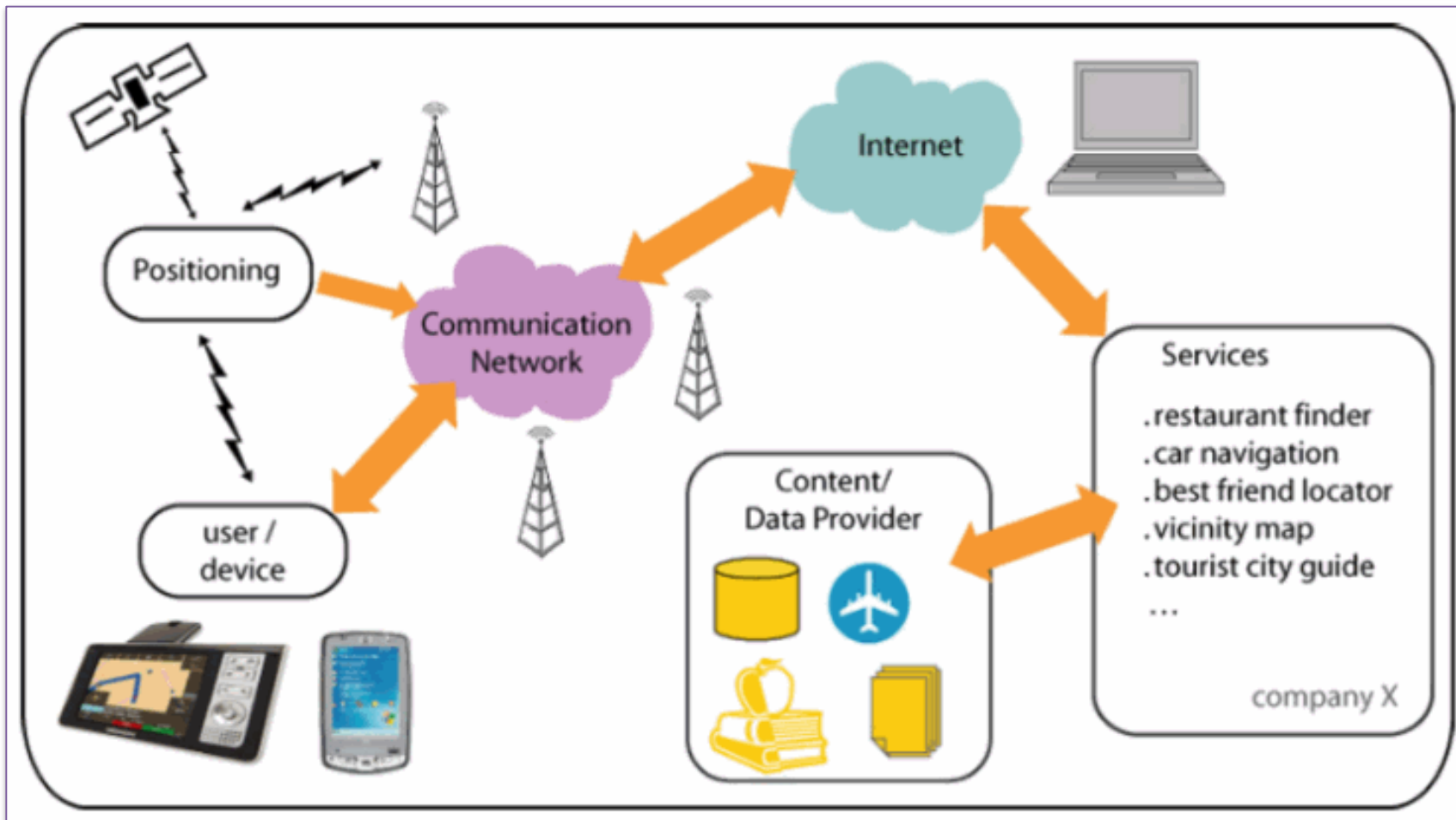

Toda a tecnologia apresentada contribui para o aparecimento dos Serviços Baseados na Localização