A Leica FlexLine TS02/TS06/TS09 total station instrument is mounted on a red tripod. The instrument is green and white, featuring a large lens and a control panel with a small screen and several buttons. The background shows a construction site with scaffolding, cranes, and buildings under a blue sky with clouds. A solid red horizontal bar is positioned at the top of the page.

Leica FlexLine TS02/TS06/TS09 User Manual

Version 1.0
English

- when it has to be **right**

Leica
Geosystems

Introduction

Purchase



Product identification

Congratulations on the purchase of a FlexLine instrument.

This manual contains important safety directions as well as instructions for setting up and operating the product. Refer to "13 Safety Directions" for further information.

Read carefully through the User Manual before you switch on the product.





The model and serial number of your product are indicated on the type plate. Enter the model and serial number in your manual and always refer to this information when you need to contact your agency or Leica Geosystems authorised service workshop.

Model: _____

Serial No.: _____

Symbols

The symbols used in this manual have the following meanings:

Type	Description
 Danger	Indicates an imminently hazardous situation which, if not avoided, will result in death or serious injury.
 Warning	Indicates a potentially hazardous situation or an unintended use which, if not avoided, could result in death or serious injury.
 Caution	Indicates a potentially hazardous situation or an unintended use which, if not avoided, may result in minor or moderate injury and/or appreciable material, financial and environmental damage.
	Important paragraphs which must be adhered to in practice as they enable the product to be used in a technically correct and efficient manner.

Trademarks

- Windows is a registered trademark of Microsoft Corporation.
 - Bluetooth is a registered trademark of Bluetooth SIG, Inc.
- All other trademarks are the property of their respective owners.

Validity of this manual

	Description
General	<p>This manual applies to TS02, TS06, and TS09 instruments. Where there are differences between the various instruments they are clearly described.</p> <p>The following symbols will identify in each section where the instruments differ:</p> <ul style="list-style-type: none">• TS02 for TS02.• TS06 for TS06.• TS09 for TS09.
Telescope	<ul style="list-style-type: none">• Measuring with Prism mode: When measuring distances to a reflector with Electronic Distance Measurement (EDM) mode "Prism", the telescope uses a wide visible red laser beam, which emerges coaxially from the telescope's objective.• Measuring with Non-Prism modes: Instruments that are equipped with a reflectorless EDM additionally offer the EDM mode "Non-Prism". When measuring distances with this EDM mode, the telescope uses a narrow visible red laser beam, which emerges coaxially from the telescope's objective.

Table of Contents

In this manual	Chapter	Page
	1 Description of the System	12
	1.1 System Components	12
	1.2 Container Contents	14
	1.3 Instrument Components	16
	2 User Interface	19
	2.1 Keyboard	19
	2.2 Screen	21
	2.3 Status Icons	22
	2.4 Softkeys	24
	2.5 Operating Principles	25
	2.6 Pointsearch	27
	3 Operation	29
	3.1 Instrument Setup	29
	3.2 Working with the Battery	35
	3.3 Data Storage	37
	3.4 Main Menu	37
	3.5 Q-Survey Application	39
	3.6 Distance Measurements - Guidelines for Correct Results	40

4	Setting	42
4.1	General Settings	42
4.2	EDM Settings	54
4.3	Communication Parameters	60
5	Tools	63
5.1	Adjust	63
5.2	Start Up Sequence	64
5.3	System Information	65
5.4	Licence Keys	67
5.5	Instrument Protection with PIN	68
5.6	Loading Software	70
6	Functions	72
6.1	Overview	72
6.2	Target Offset	74
	6.2.1 Overview	74
	6.2.2 Cylinder Offset Subapplication	76
6.3	Height Transfer	80
6.4	Hidden Point	81
6.5	Check Tie	84
6.6	EDM Tracking	86
7	Coding	87
7.1	Standard Coding	87

7.2	Quick Coding	89
8	Applications - Getting Started	91
<hr/>		
8.1	Overview	91
8.2	Starting an Application	92
8.3	Setting the Job	94
8.4	Setting the Station	95
8.5	Setting the Orientation	97
	8.5.1 Overview	97
	8.5.2 Manual Orientation	98
	8.5.3 Orientation with Coordinates	99
9	Applications	103
<hr/>		
9.1	Common Fields	103
9.2	Surveying	104
9.3	Stakeout	105
9.4	Free Station	111
	9.4.1 Starting Free Station	111
	9.4.2 Measuring Information	113
	9.4.3 Computation Procedure	114
	9.4.4 Free Station Results	115
9.5	Reference Element - Reference Line	118
	9.5.1 Overview	118
	9.5.2 Defining the Base Line	119
	9.5.3 Defining the Reference Line	120
	9.5.4 Subapplication Measure Line & Offset	123

	9.5.5	Subapplication Stakeout	125
	9.5.6	Subapplication Grid Stakeout	127
	9.5.7	Subapplication Line Segmentation	131
9.6		Reference Element - Reference Arc	136
	9.6.1	Overview	136
	9.6.2	Defining the Reference Arc	137
	9.6.3	Subapplication Measure Line & Offset	139
	9.6.4	Subapplication Stakeout	141
9.7		Tie Distance	146
9.8		Area & Volume	149
9.9		Remote Height	153
9.10		Construction	154
	9.10.1	Starting Construction	154
	9.10.2	Layout	155
	9.10.3	As Built Check	157
9.11		COGO	159
	9.11.1	Starting COGO	159
	9.11.2	Inverse and Traverse	159
	9.11.3	Intersections	161
	9.11.4	Offsets	163
	9.11.5	Extension	165
9.12		Road 2D	166
9.13		Roadworks 3D	171
	9.13.1	Starting Roadworks 3D	171
	9.13.2	Basic Terms	173

9.13.3	Creating or Uploading Alignment Files	181
9.13.4	Subapplication Stake	184
9.13.5	Subapplication Check	187
9.13.6	Subapplication Stake Slope	189
9.13.7	Subapplication Check Slope	195
9.14	TraversePRO	197
9.14.1	Overview	197
9.14.2	Starting and Configuring TraversePRO	199
9.14.3	Measuring Traverse	202
9.14.4	Moving ahead	205
9.14.5	Closing a Traverse	208
9.15	Reference Plane	214
10	Data Management	218
10.1	File Management	218
10.2	Exporting Data	220
10.3	Importing Data	224
10.4	Working with a USB Memory Stick	226
10.5	Working with Bluetooth	228
10.6	Working with Leica FlexOffice	230
11	Check & Adjust	231
11.1	Overview	231
11.2	Preparation	232
11.3	Adjusting Line-of-Sight and Vertical Index Error	233
11.4	Adjusting the Tilting Axis Error	237

11.5	Adjusting the Circular Level of the Instrument and Tribrach	240
11.6	Inspecting the Laser Plummet of the Instrument	241
11.7	Servicing the Tripod	243
12	Care and Transport	244
<hr/>		
12.1	Transport	244
12.2	Storage	245
12.3	Cleaning and Drying	246
13	Safety Directions	247
<hr/>		
13.1	General	247
13.2	Intended Use	247
13.3	Limits of Use	249
13.4	Responsibilities	249
13.5	Hazards of Use	250
13.6	Laser Classification	255
13.6.1	General	255
13.6.2	Distancer, Measurements with Reflectors	256
13.6.3	Distancer, Measurements without Reflectors (Non-Prism mode)	258
13.6.4	Electronic Guide Light EGL	262
13.6.5	Laser Plummet	263
13.7	Electromagnetic Compatibility EMC	266
13.8	FCC Statement, Applicable in U.S.	268

14 Technical Data	271
14.1 Angle Measurement	271
14.2 Distance Measurement with Reflectors	272
14.3 Distance Measurement without Reflectors (Non-Prism mode)	274
14.4 Distance Measurement Reflector (>3.5 km)	276
14.5 Conformity to National Regulations	277
14.5.1 Products without Communication side cover	277
14.5.2 Products with Communication side cover	278
14.6 General Technical Data of the Instrument	279
14.7 Scale Correction	285
14.8 Reduction Formulas	288
15 International Limited Warranty, Software License Agreement	290
16 Glossary	292
Appendix A Menu Tree	296
Appendix B Directory Structure	299
Index	300

1 Description of the System

1.1 System Components

Main Components

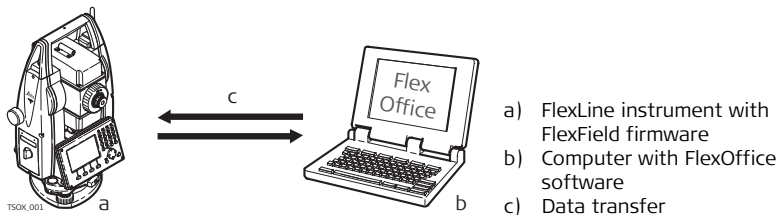

Component	Description
FlexLine instrument	An instrument for measuring, calculating and capturing data. Ideally suited for tasks from simple surveys to complex applications. Equipped with a FlexField firmware package to complete these tasks. The various lines have a range of accuracy classes and support different features. All lines can be connected with FlexOffice to view, exchange and manage data.
FlexField firmware	The firmware package installed on the instrument. Consists of a standard base operating system with optional additional features.

Component	Description
FlexOffice software	An office software consisting of a suite of standard and extended programs for the viewing, exchanging, managing and post processing of data.
Data transfer	Data can be always transferred between a FlexLine instrument and a computer via a data transfer cable. For instruments equipped with a Communication side cover data can also be transferred via USB memory stick, USB cable, or Bluetooth.

1.2

Container Contents

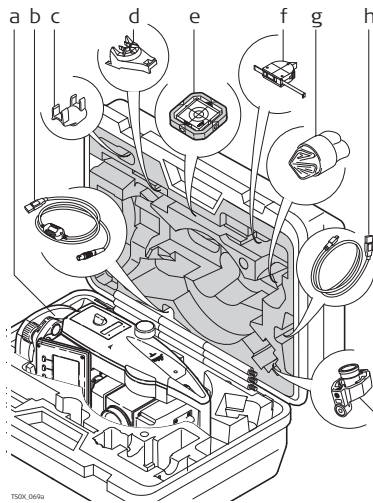
Container contents
part 1 of 2

- a) Instrument with supplied tribrach
- b) GEV189 data cable (USB-RS232)*
- c) GLI115 clip-on bubble*
- d) GHT196 holder for height meter*
- e) CPR105 flat prism*
- f) GHM007 height meter*
- g) Protective cover / Lens hood*
- h) GEV223 data cable (USB-mini USB) - for instruments with a Communication side cover
- i) GMP111 mini prism*

* Optional

Container contents part 2 of 2

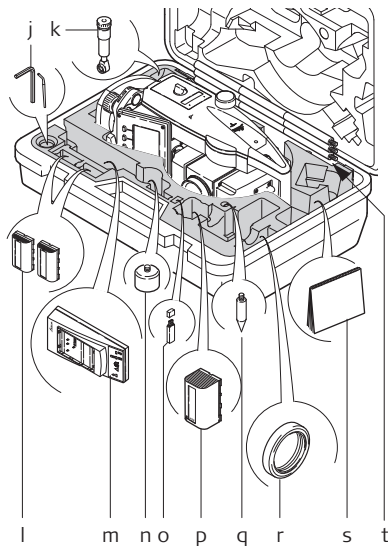

TS0X_06/06

- j) Adjustment tools
- k) GFZ3 diagonal eyepiece*
- l) GEB211 batteries*
- m) GKL211 battery charger*
- n) GAD105 flat or mini prism adapter*
- o) MS1 Leica industrial grade USB
memory stick - for instruments with a
Communication side cover
- p) GEB221 battery*
- q) Tip for mini prism pole*
- r) Counterweight for diagonal
eyepiece*
- s) User manual
- t) GLS115 mini prism pole*

* Optional

1.3 Instrument Components

Instrument components part 1 of 2

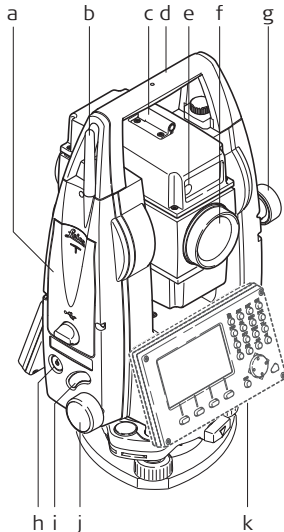

TSOK_009a

- a) Compartment for USB memory stick and USB cable ports*
- b) Bluetooth antenna*
- c) Optical sight
- d) Detachable carrying handle with mounting screw
- e) Electronic Guide Light (EGL)*
- f) Objective with integrated Electronic Distance Measurement (EDM). Exit for EDM laser beam
- g) Vertical drive
- h) On/Off key
- i) Trigger key
- j) Horizontal drive
- k) Second keyboard*

* Optional

Instrument components part 2 of 2

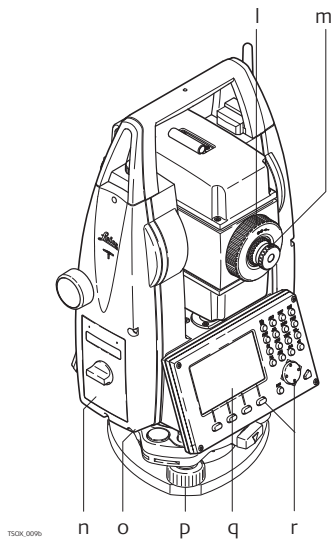

- l) Focusing telescope image
- m) Eyepiece; focusing graticule
- n) Battery cover
- o) Serial interface RS232
- p) Foot screw
- q) Display
- r) Keyboard

Communication side cover

A Communication side cover is optional for **TS02 TS06** and included for **TS09**.

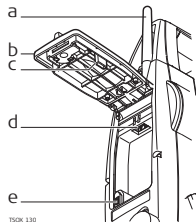

- a) Bluetooth antenna
- b) Compartment lid
- c) USB memory stick cap storage
- d) USB host port
- e) USB device port

2

User Interface

2.1

Keyboard

Keyboard

Standard keyboard

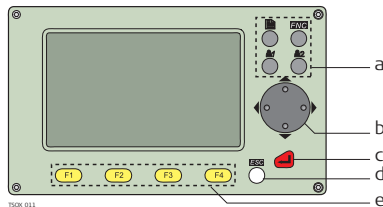



- a) Fixed keys
- b) Navigation key
- c) **ENTER** key

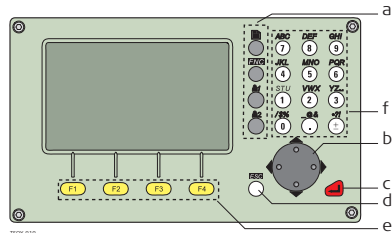





Alphanumeric keyboard



- d) **ESC** key
- e) Function keys **F1** to **F4**
- f) Alphanumeric keypad

Keys

Key	Description
	Page key. Displays the next screen when several screens are available.
	FNC key. Quick-access to measurement supporting functions.

Key	Description
	User key 1. Programmable with a function from the FNC menu.
	User key 2. Programmable with a function from the FNC menu.
	Navigation key. Controls the focus bar within the screen and the entry bar within a field.
	ENTER key. Confirms an entry and continues to the next field.
	ESC key. Quits a screen or edit mode without saving changes. Returns to next higher level.
	Function keys that are assigned the variable functions displayed at the bottom of the screen.
	Alphanumeric keypad for entry of text and numerical values.

Sidecover keys

Key	Description
	On / Off key. Switches the instrument on or off.

Key	Description
	<p>Trigger key. Quick key programmable with functions ALL or DIST, if desired.</p> <p>TS06 TS09 Programmable with both of the functions.</p> <p>TS02 Programmable with one of the functions.</p> <p>The trigger key can be programmed in the Settings screen. Refer to "4.1 General Settings".</p>

2.2

Screen

Screen

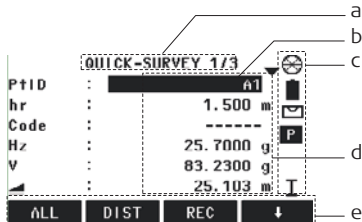

S_TS0X_001



All shown screens are examples. It is possible that local firmware versions are different to the basic version.











- a) Title of screen
- b) Focus in screen. Active field
- c) Status icons
- d) Fields
- e) Softkeys











2.3 Status Icons

Description

The icons provide status information related to basic instrument functions. Depending on the firmware version, different icons are displayed.

Icons

Icon	Description
	The battery symbol indicates the level of the remaining battery capacity, 75% full shown in the example.
	Compensator is on.
	Compensator is off.
	Prism EDM mode for measuring to prisms and reflective targets.
	Non-Prism EDM mode for measuring to all targets.
	Offset is active.
	Keypad is set to numeric mode.
	Keypad is set to alphanumeric mode.
	Indicates that horizontal angle is set to left side angle measurement (anticlockwise).
	A double arrow indicates a field has a selectable list.

Icon	Description
	Up and down arrows indicate that several screens are available, which are accessed using  .
I	Indicates telescope position is face I.
II	Indicates telescope position is face II.
	Leica standard prism is selected.
	Leica mini prism is selected.
	Leica 360° prism is selected.
	Leica 360° mini prism is selected.
	Leica reflector tape is selected.
	User defined prism is selected.
	Bluetooth is connected. If there is a cross beside the icon, the Bluetooth communication port is selected, but the status is inactive.
	USB communication port is selected.

2.4

Softkeys

Description

Softkeys are selected using the relevant **F1** to **F4** function key. This chapter describes the functionality of the common softkeys used by the system. The more specialised softkeys are described where they appear in the application chapters.

Common softkey functions

Key	Description
-> ABC	To change the keypad operation to alphanumerical.
-> 012	To change the keypad operation to numerical.
ALL	To start distance and angle measurements and save the measured values.
DIST	To start distance and angle measurements without saving the measured values.
EDM	To view and change EDM settings. Refer to "4.2 EDM Settings".
ENH	To open the manual coordinate entry screen.
EXIT	To exit the screen or application.
FIND	To search for an entered point.
INPUT	TS02 To activate alphanumerical softkeys for text entry.
P/NP	To toggle between Prism and Non-Prism EDM modes.
LIST	To display the list of available points.

Key	Description
OK	If entry screen: Confirms measured or entered values and continues the process. If message screen: Confirms message and continues with selected action or returns to the previous screen to reselect an option.
PREV	To return to the last active screen.
REC	To save the displayed values.
RESET	To reset all editable fields to their default values.
VIEW	To display the coordinate and job details of the selected point.
↓	To display the next softkey level.
←	To return to the first softkey level.

2.5

Operating Principles

Turn instrument on/off

Use the On/Off key on the side cover of the instrument.

Selection of language

After switching on the instrument the user is able to choose their preferred language. The language choice screen is only shown if multiple languages are loaded onto the instrument and **Lang.choice: On** is set in the instrument settings. Refer to "4.1 General Settings".

Alphanumeric keypad

The alphanumeric keypad is used to enter characters directly into editable fields.

- **Numeric fields:** Can only contain numerical values. By pressing a key of the keypad the number will be displayed.
- **Alphanumeric fields:** Can contain numbers and letters. By pressing a key of the keypad the first character written above that key will be displayed. By pressing several times you can toggle through the characters. For example: 1- >S- >T- >U- >1- >S....

Standard keyboard

To enter characters using a standard keypad, select **INPUT** and the softkeys will change to represent the alphanumeric characters available in edit mode. Select the appropriate softkey for entry of the character.

Edit fields

ESC Deletes any change and restores the previous value.



Moves the cursor to the left.



Moves the cursor to the right.



Inserts a character at the cursor position.



Deletes the character at the cursor position.



In edit mode the position of the decimal place cannot be changed. The decimal place is skipped.

Special characters

Character	Description
*	Used as wildcards in search fields for point numbers or codes. Refer to "2.6 Pointsearch".
+/-	In the alphanumeric character set "+" and "-" are treated as normal alphanumeric characters with no mathematical function.  "+" / "-" only appear in front of an entry.

PROGRAMS 1/4		▼
F1	Surveying	(1)
F2	Stakeout	(2)
F3	Free Station	(3)

In this example selecting 2 on an alphanumeric keyboard would start the Stakeout application.

2.6

Pointsearch

Description

Pointsearch is a function used by applications to find measured or fixed points in the memory storage.

It is possible to limit the point search to a particular job or to search the whole storage. The search procedure always finds fixed points before measured points that fulfill the same search criteria. If several points meet the search criteria, then the results are ordered according to the entry date. The instrument finds the most recent fixed point first.

Direct search

By entering an actual point number, for example 402, and pressing **SEARCH**, all points within the selected job and with the corresponding point number are found.

```

POINTSEARCH
Job :      J101
PtID:      402

Select job or enter
point coordinates manually!

SEARCH  ENH=0  ENH

```

SEARCH

To search for matching points within the selected job.

ENH=0

To set all ENH coordinates for the point ID to 0.

Wildcard search

The wildcard search is indicated by a "*". The asterisk is a place holder for any following sequence of characters. Wildcards should be used if the point number is not fully known, or to search for a batch of points.

Examples of point searches

- * All points are found.
- A All points with exactly the point number "A" are found.
- A* All points starting with "A" are found, for example, A9, A15, ABCD, A2A.
- *1 All points containing only one "1" are found, for example, 1, A1, AB1.
- A*1 All points starting with "A" and containing only one "1" are found, for example, A1, AB1, A51.

3

3.1

Operation

Instrument Setup

Description

This topic describes an instrument setup over a marked ground point using the laser plummet. It is always possible to set up the instrument without the need for a marked ground point.



Important features

- It is always recommended to shield the instrument from direct sunlight and avoid uneven temperatures around the instrument.
- The laser plummet described in this topic is built into the vertical axis of the instrument. It projects a red spot onto the ground, making it appreciably easier to center the instrument.
- The laser plummet cannot be used in conjunction with a tribrach equipped with an optical plummet.

Tripod

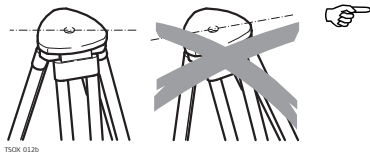

When setting up the tripod pay attention to ensuring a horizontal position of the tripod plate. Slight corrections of inclination can be made with the foot screws of the tribrach. Larger corrections must be done with the tripod legs.

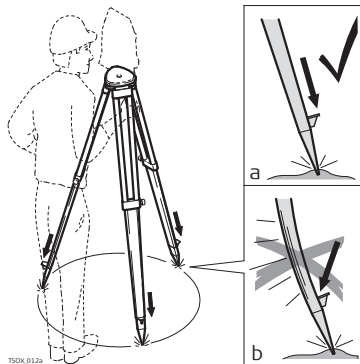

TSOK_012a

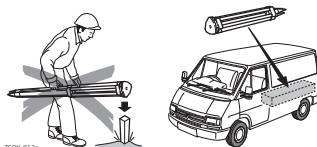

TSOK_012c

Loosen the clamping screws on the tripod legs, pull out to the required length and tighten the clamps.

- In order to guarantee a firm foothold sufficiently press the tripod legs into the ground.
- When pressing the legs into the ground note that the force must be applied along the legs.

Careful handling of tripod.

- Check all screws and bolts for correct fit.
- During transport always use the cover supplied.
- Use the tripod only for surveying tasks.

Setup step-by-step

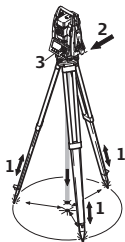

TSOK_013

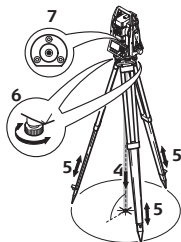

1. Extend the tripod legs to allow for a comfortable working posture. Position the tripod over the marked ground point, centering it as best as possible.
2. Fasten the tribrach and instrument onto the tripod.
3. Turn on the instrument, and, if tilt correction is set to 1- or 2-axis, the laser plummet will be activated automatically, and the **Level/Plummet** screen appears. Otherwise, press **FNC** from within any application and select **Level/Plummet**.
4. Move the tripod legs (1) and use the tribrach footscrews (6) to center the plummet (4) over the ground point.
5. Adjust the tripod legs (5) to level the circular level (7).
6. By using the electronic level, turn the tribrach footscrews (6) to precisely level the instrument. Refer to "Level up with the electronic level step-by-step".
7. Center the instrument precisely over the ground point by shifting the tribrach on the tripod plate (2).
8. Repeat steps 6. and 7. until the required accuracy is achieved.

Level up with the electronic level step-by-step

The electronic level can be used to precisely level up the instrument using the footscrews of the tribrach.

1. Turn the instrument until it is parallel to two footscrews.
2. Center the circular level approximately by turning the footscrews of the tribrach.
3. Turn on the instrument, and, if tilt correction is set to 1- or 2-axis, the laser plummet will be activated automatically, and the **Level/Plummet** screen appears. Otherwise, press **FNC** from within any application and select **Level/Plummet**.



The bubble of the electronic level and the arrows for the rotating direction of the footscrews only appear if the instrument tilt is inside a certain levelling range.

4. Center the electronic level of the first axis by turning the two footscrews. Arrows show the direction of rotation required. When the electronic level is centered the arrows are replaced by checkmarks.

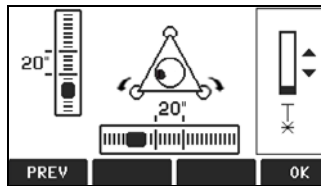

5. Center the electronic level for the second axis by turning the last footscrew. An arrow shows the direction of rotation required. When the electronic level is centered the arrow is replaced by a checkmark.



When the electronic level is centered and three checkmarks are shown, the instrument has been perfectly levelled up.

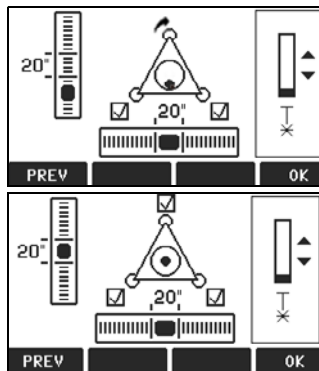

6. Accept with **OK**.

Change the intensity of the laser plummet

External influences and the surface conditions may require the adjustment of the intensity of the laser plummet.

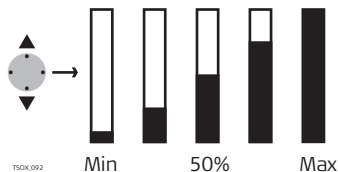

In the **Level/Plummet** screen, adjust the intensity of the laser plummet using the navigation key. The laser can be adjusted in 25% steps as required.

Position over pipes or holes

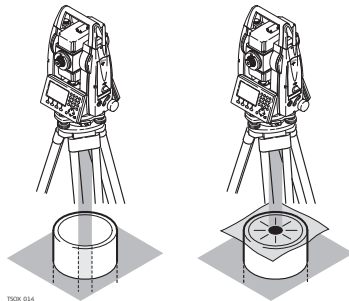

Under some circumstances the laser dot is not visible, for example over pipes. In this case, using a transparent plate enables the laser dot to be seen and then easily aligned to the center of the pipe.

3.2



Working with the Battery

Charging / first-time use

- The battery must be charged prior to using it for the first time because it is delivered with an energy content as low as possible.
- For new batteries or batteries that have been stored for a long time (> three months), it is effectual to make only one charge/discharge cycle.
- The permissible temperature range for charging is between 0°C to +40°C/+32°F to +104°F. For optimal charging we recommend charging the batteries at a low ambient temperature of +10°C to +20°C/+50°F to +68°F if possible.
- It is normal for the battery to become warm during charging. Using the chargers recommended by Leica Geosystems, it is not possible to charge the battery if the temperature is too high.

Operation / discharging

- The batteries can be operated from -20°C to +50°C/-4°F to +122°F.
 - Low operating temperatures reduce the capacity that can be drawn; very high operating temperatures reduce the service life of the battery.
 - For Li-Ion batteries, we recommend carrying out a single discharging and charging cycle when the battery capacity indicated on the charger or on a Leica Geosystems product deviates significantly from the actual battery capacity available.
-

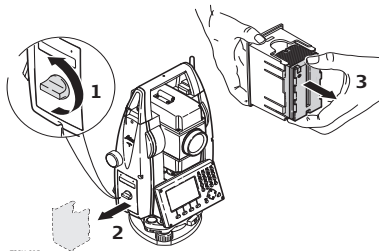
**Change the battery
step-by-step**

TSOK_015

Open the battery compartment (1) and remove the battery holder (2).

Remove the battery from the battery holder (3).

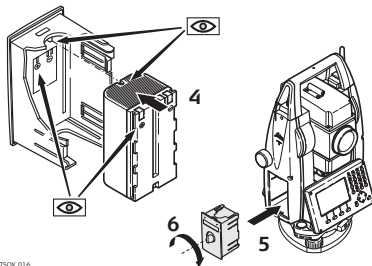

TSOK_016

Insert the new battery into the battery holder (4), ensuring that the contacts are facing outward. The battery should click into position.

Insert the battery holder back into the battery compartment (5) and turn the knob to lock the battery holder in place (6).



The polarity of the battery is displayed inside the battery housing.

3.3

Data Storage

Description

An internal memory is included in all instruments. The FlexField firmware stores all data in jobs in a database in the internal memory. Data can then be transferred to a computer or other device for post processing via a LEMO cable connected to the serial interface RS232 port.

For instruments fitted with a Communication side cover, data can also be transferred from the internal memory to a computer or other device via:

- a USB memory stick inserted into the USB host port,
- a USB cable connected to the USB device port, or
- via a Bluetooth connection.

Refer to "10 Data Management" for further information on data management and data transfer.

3.4

Main Menu

Description

The **MAIN MENU** is the starting place for accessing all functionality of the instrument. It is usually displayed immediately after the Level/Plummet screen, after switching on the instrument.



If desired, the instrument can be configured to start in a user defined place after the Level/Plummet screen, instead of the **MAIN MENU**. Refer to "5.2 Start Up Sequence".

MAIN MENU

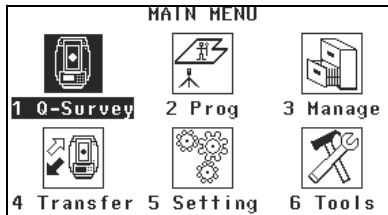

Description of the MAIN MENU functions

Function	Description
Q-Survey	Quick Survey program to begin measuring immediately. Refer to "3.5 Q-Survey Application".
Prog	To select and start applications. Refer to "9 Applications".
Manage	To manage jobs, data, codelists, formats, system memory and USB memory stick files. Refer to "10 Data Management".
Transfer	To export and import data. Refer to "10.2 Exporting Data".
Setting	To change EDM configurations, communication parameters and general instrument settings. Refer to "4 Setting".
Tools	To access instrument related tools such as check and adjust calibrations, personal start up settings, PIN code settings, licence keys and system information. Refer to "5 Tools".

3.5

Q-Survey Application

Description

After switching on and setting up correctly, the instrument is immediately ready for measuring.

Access

Select **Q-Survey** from the **MAIN MENU**.

QUICK-SURVEY

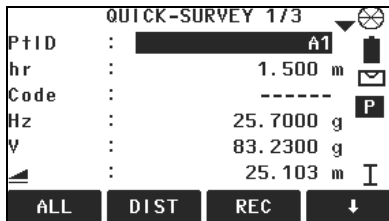

↓ CODE

To find/enter codes. Refer to "7.1 Standard Coding".

↓ STATION

To enter station data and set the station.

↓ Hz=0

To set the orientation to horizontal direction = 0.

↓ Hz← / Hz→

To set the horizontal angle reading to the left (anticlockwise) or to the right (clockwise).

The procedure for **Q-Survey** is identical to the procedure for the application **Surveying**. Therefore this procedure is only described once within the application chapter. Refer to "9.2 Surveying".

3.6 Distance Measurements - Guidelines for Correct Results

Description

A laser distancer (EDM) is incorporated into the FlexLine instruments. In all versions, the distance can be determined by using a visible red laser beam which emerges coaxially from the telescope objective. There are two EDM modes:

- Prism measurements
- Non-Prism measurements

Non-Prism measurements

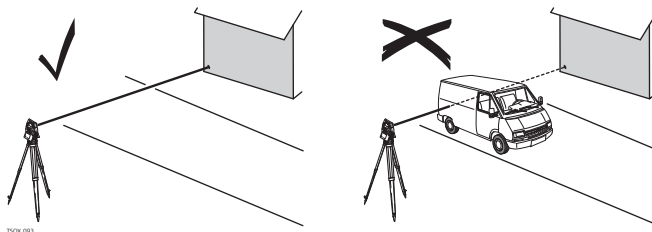

- When a distance measurement is triggered, the EDM measures to the object which is in the beam path at that moment. If a temporary obstruction, for example a passing vehicle, heavy rain, fog or snow is between the instrument and the point to be measured, the EDM may measure to the obstruction.
- Be sure that the laser beam is not reflected by anything close to the line of sight, for example highly reflective objects.
- Avoid interrupting the measuring beam while taking Non-Prism measurements or measurements using reflective foils.

- Do not measure with two instruments to the same target simultaneously.
-

Prism measurements

- Accurate measurements to prisms should be made in Prism-standard mode.
 - Measurements to strongly reflecting targets such as traffic lights in Prism mode without a prism should be avoided. The measured distances may be wrong or inaccurate.
 - When a distance measurement is triggered, the EDM measures to the object which is in the beam path at that moment. If for example people, cars, animals, or swaying branches cross the laser beam while a measurement is being taken, a fraction of the laser beam is reflected from these objects and may lead to incorrect distance values.
 - Measurements to prisms are only critical if an object crosses the measuring beam at a distance of 0 to 30 m and the distance to be measured is more than 300 m.
 - In practice, because the measuring time is very short, the user can always find a way of avoiding unwanted objects from interfering in the beam path.
-

Red laser to prism

- Prism (>3.5 km) mode enables distance measurements of over 3.5 km to standard prisms using the visible red laser beam.
-

Red laser to reflector tape

- The visible red laser beam can also be used to measure to reflective foils. To guarantee the accuracy the red laser beam must be perpendicular to the reflector tape and it must be well adjusted.
 - Make sure the additive constant belongs to the selected target (reflector).
-

4 Setting

4.1 General Settings

Access

1. Select **Setting** from the **MAIN MENU**.
2. Select **General** from the **SETTINGS MENU**.
3. Press  to scroll through the screens of available settings.

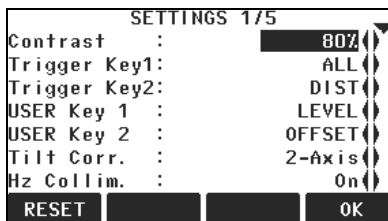

SETTINGS



DelLang

To delete a selected language.

Field	Description
Contrast	0% to 100% Sets the display contrast in 10% steps.
Trigger Key1 / Key2	Trigger Key 1 is the top end of the trigger key. Trigger Key 2 is the lower end of the trigger key. Off The trigger key is deactivated.

Field	Description	
	ALL	Sets the trigger key with the same function as ALL .
	DIST	Sets the trigger key with the same function as DIST .
USER Key 1 / Key 2	Configures  or  with a function from the FNC menu. Refer to "6 Functions".	
Tilt Corr.	Off	Tilting compensation deactivated.
	1-axis	Vertical angles refer to the plummet line.
	2-axis	Vertical angles refer to the plummet line and the horizontal directions are corrected by the standing axis tilt. For corrections depending on the Hz Corr: setting, refer to the table "Tilt and horizontal corrections".
	If the instrument is used on an unstable base, for example a shaking platform or ship, the compensator should be deactivated. This avoids the compensator drifting out of it's measuring range and interrupting the measuring process by indicating an error.	

Field	Description
Hz Corr.	On Horizontal corrections are activated. For normal operation the horizontal correction should remain active. Each measured horizontal angle will be corrected, depending on the vertical angle. For corrections depending on the Tilt Corr: setting, refer to the table "Tilt and horizontal corrections".
	Off Horizontal corrections are deactivated.
Beep	The beep is an acoustic signal after each key stroke.
	Normal Normal volume.
	Loud Increased volume.
Off	Beep is deactivated.
	Sector Beep On Sector Beep sounds at right angles (0°, 90°, 180°, 270° or 0, 100, 200, 300 gon).

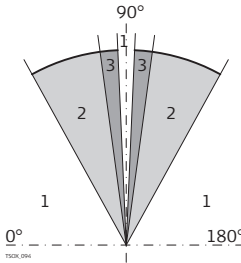
Field	Description	
	<div style="display: flex; align-items: center;">  <div style="margin-left: 20px;"> <p>1.No beep.</p> <p>2.Fast beep; from 95.0 to 99.5 gon and 105.0 to 100.5 gon.</p> <p>3.Permanent beep; from 99.5 to 99.995 gon and from 100.5 to 100.005 gon.</p> </div> </div>	
Hz Increment	Right	Set horizontal angle to clockwise direction measurement.
	Left	Set horizontal angle to counter-clockwise direction measurement. Counter-clockwise directions are displayed but are saved as clockwise directions.
V-Setting	Sets the vertical angle.	

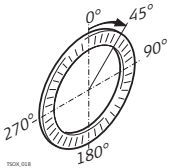
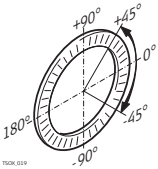
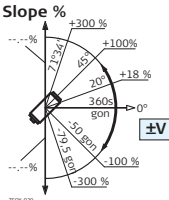

Field	Description
	<p>Zenith</p>  <p>Zenith=0°; Horizon=90°.</p>
	<p>Horiz.</p>  <p>Zenith=90°; Horizon=0°. Vertical angles are positive above the horizon and negative below it.</p>
	<p>Slope %</p>  <p>Slope %</p> <p>45°=100%; Horizon=0°. Vertical angles are expressed in % with positive above the horizon and negative below it. The % value increases rapidly. --.--% appears on the display above 300%.</p>

Field	Description
Face I Def.	<p>Sets the face I in relation to the position of the vertical drive.</p> <p>V-Left Sets face I to be when the vertical drive is on the left of the instrument.</p> <p>V-Right Sets face I to be when the vertical drive is on the right of the instrument.</p>
Language	<p>Sets the chosen language. An unlimited number of languages can be uploaded onto the instrument. The current loaded language(s) are shown.</p> <p>A selected language can be deleted by pressing DelLang. This function is available on page 2 of the SETTINGS screen if more than one language is installed, and the selected language is not the chosen operating language.</p>
Lang. Choice	<p>If multiple languages are loaded, a screen to choose the language can be shown directly after switching on the instrument.</p> <p>On The language screen is shown as the startup screen.</p> <p>Off The language screen is not shown as the startup screen.</p>
Angle Unit	Sets the units shown for all angular fields.

Field	Description
	<p>° ' " Degree sexagesimal. Possible angle values: 0° to 359°59'59"</p> <p>dec. deg Degree decimal. Possible angle values: 0° to 359.999°</p> <p>gon Gon. Possible angle values: 0 gon to 399.999 gon</p> <p>mil Mil. Possible angle values: 0 to 6399.99mil.</p> <p>The setting of the angle units can be changed at any time. The actual displayed values are converted according to the selected unit.</p>
Min. Reading	<p>Sets the number of decimal places shown for all angular fields. This is for data display and does not apply to data export or storage.</p> <p>For Angle Unit ° ' ": (0° 00' 01" / 0° 00' 05" / 0° 00' 10").</p> <p>Dec.deg: (0.0001 / 0.0005 / 0.001).</p> <p>Gon: (0.0001 / 0.0005 / 0.001).</p> <p>Mil: (0.01 / 0.05 / 0.1).</p>
Dist. Unit	<p>Sets the units shown for all distance and coordinate related fields.</p> <p>Meter Meters [m].</p> <p>US-ft US feet [ft].</p> <p>INT-ft International feet [fi].</p>

Field	Description
	ft-in/16 US feet-inch-1/16 inch [ft].
Dist.Decimal	Sets the number of decimal places shown for all distance fields. This is for data display and does not apply to data export or storage. 3 Displays distance with three decimals. 4 Displays distance with four decimals.
Temp. Unit	Sets the units shown for all temperature fields. °C Degree Celsius. °F Degree Fahrenheit.
Press.Unit	Sets the units shown for all pressure fields. hPa Hecto Pascal. mbar Millibar. mmHg Millimeter mercury. inHg Inch mercury.
Grade Unit	Sets how the slope gradient is calculated. h:v Horizontal : Vertical, for example 5 : 1. v:h Vertical : Horizontal, for example 1 : 5. % (v/h x 100), for example 20 %.

Field	Description
Data Output	<p>Sets the location for data storage.</p> <p>Int.Mem. All data is recorded in the internal memory.</p> <p>Interf. Data is recorded via the serial interface or the USB device port, depending on the port selected in the COMMUNICATION PARAMETERS screen. This Data Output setting is only required if an external storage device is connected and measurements are started at the instrument with DIST/REC or ALL. This setting is not required if the instrument is totally controlled by a datalogger.</p>
GSI Format	<p>Sets the GSI output format.</p> <p>GSI 8 81..00+12345678</p> <p>GSI 16 81..00+1234567890123456</p>
GSI Mask	<p>Sets the GSI output mask.</p> <p>Mask1 PtID, Hz, V, SD, ppm+mm, hr, hi.</p> <p>Mask2 PtID, Hz, V, SD, E, N, H, hr.</p>

Field	Description
	<p>Mask3 StationID, E, N, H, hi (Station). StationID, Ori, E, N, H, hi (Station Result). PtID, E, N, H (Control). PtID, Hz, V (Set Azimuth). PtID, Hz, V, SD, ppm+mm, hr, E, N, H (Measurement).</p>
Code record	Sets if the codeblock is saved before or after the measurement. Refer to "7 Coding".
Code	<p>Sets if the code will be used for one, or many, measurements.</p> <p>Reset after REC The set code is cleared from the measurement screen after ALL or REC is selected.</p> <p>Permanent The set code remains in the measurement screen until manually deleted.</p>
Display ill.	Off to 100% Sets the display illumination in 20% steps.
Reticle ill.	Off to 100% Sets the reticle illumination in 20% steps.
Displ.Heater	<p>On The display heater is activated.</p> <p>Off The display heater is deactivated.</p> <p> The display heater is automatically activated when the display illumination is on and the instrument temperature is $\leq 5^{\circ}\text{C}$.</p>
Pre-/Suffix	 Only used for the Stakeout application.

Field	Description	
	Prefix	Adds the character entered for Identifier in front of the original point number of the point to be staked.
	Suffix	Adds the character entered for Identifier at the end of the original point number of the point to be staked.
	Off	The staked point is stored with the same point number as the point to be staked.
Identifier		Only used for the Stakeout application. The identifier can be up to four characters and is added at the start, or end, of a point number of a point to be staked.
Sort Type	Time	Lists are sorted by time of entry.
	PtID	Lists are sorted by Point IDs.
Sort Order	Descen.	Lists are ordered in descending order of sort type.
	Ascen.	Lists are ordered in ascending order of sort type.
Double PtID		Sets if multiple points are able to be recorded with the same point ID.
	Allowed	Allows multiple points with the same point ID.

Field	Description	
	Not Allowed	Does not allow multiple points with the same point ID.
Auto-Off	Enable	The instrument switches off after 20 minutes without any activity, for example no key pressed or vertical and horizontal angle deviation is $\leq \pm 3''$.
	Disable	Automatic switch-off is deactivated.  Battery discharges quicker.

Tilt and horizontal corrections

Setting		Correction			
Tilt correction	Horizontal correction	Incline longitudinal	Incline transversal	Horizontal collimation	Tilting axis
Off	On	No	No	Yes	Yes
1-Axis	On	Yes	No	Yes	Yes
2-Axis	On	Yes	Yes	Yes	Yes
Off	Off	No	No	No	No
1-Axis	Off	Yes	No	No	No
2-Axis	Off	Yes	No	No	No

4.2 EDM Settings

Description

The settings on this screen define the active EDM, **E**lectronic **D**istance **M**easurement. Different settings for measurements are available with Non-Prism (NP) and Prism (P) EDM modes.

Access

1. Select **Settings** from the **MAIN MENU**.
2. Select **EDM** from the **SETTINGS MENU**.

EDM SETTINGS

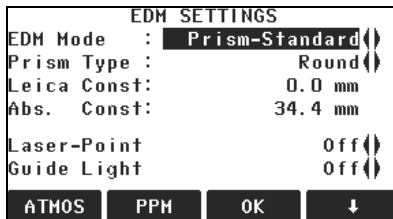

ATMOS

To enter atmospheric data ppm.

PPM

To enter an individual ppm value.

↓ SCALE

To enter projection scale details.

↓ SIGNAL





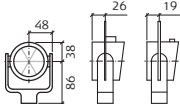

To view EDM Signal reflection value.

↓ FREQ.

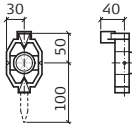
To view the EDM frequency.

Field	Description
EDM mode	Prism-Standard Fine measuring mode for high precision measurements with prisms.

Field	Description
	<p>Non-Prism-Std. For distance measurements without prisms.</p> <p>Non-Prism-Track. For continuous distance measurements without prisms.</p> <p>Prism (>3.5km) For long range distance measurements with prisms.</p> <p>Prism-Fast Quick measuring mode with prisms, with higher measuring speed and reduced accuracy.</p> <p>Prism-Tracking For continuous distance measurements with prisms.</p> <p>Tape For distance measurements using Retro reflective targets.</p> <p>FlexPoint Included for TS06 and TS09. Optional for TS02. Allows short distances, ~30 m, to be measured without a reflector.</p>
Prism Type	<p>Round</p>  <p>Standard prism GPR121/111 Leica Constant: 0.0 mm</p>

Field	Description
	<p>Mini</p>  <p>GMP111 Leica Constant: +17.5 mm</p> <p>GMP111-0 Leica Constant: 0.0 mm</p>
	<p>JpMini</p> <p>Miniprism</p>  <p>GRZ4/122 Leica Constant: +34.4 mm</p>
	<p>360°</p>   <p>GRZ101 Leica Constant: +23.1 mm</p>
	<p>360° Mini</p>   <p>GRZ101 Leica Constant: +30.0 mm</p> <p>User1 / User2</p> <p>The user can define two of their own prisms. Constants can be entered in mm in either Leica Const: or Abs. Const:. For example:</p> <p>User prism constant = -30.0 mm</p> <p>Leica Const: = +4.4 mm (34.4 + -30 = 4.4)</p> <p>Abs. Const: = -30.0 mm</p>

Field	Description
	<p>Tape  Leica Constant: +34.4 mm</p> <p>None Without prism Leica Constant: +34.4 mm</p>
Leica Const.	<p>This field displays the Leica prism constant for the selected Prism Type: Where Prism Type: is User 1 or User 2 this field becomes editable to set a user defined constant. Input can only be made in mm. Limit value: -999.9 mm to +999.9 mm.</p>
Abs. Const	<p>This field displays the absolute prism constant for the selected Prism Type: Where Prism Type: is User 1 or User 2 this field becomes editable to set a user defined constant. Input can only be made in mm. Limit value: -999.9 mm to +999.9 mm.</p>
Laser-Point	<p>Off Visible laser beam is deactivated.</p> <p>On Visible laser beam for visualising the target point is activated.</p>
Guide Light	<p>Off Guide Light is deactivated.</p> <p>On Guide Light is activated. The person at the prism can be guided by the flashing lights directly to the line of sight. The light points are visible up to a distance of 150 meters. This is useful when staking out points.</p>

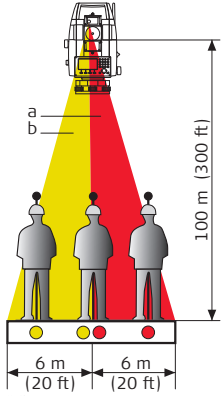
Field	Description
	<p data-bbox="710 158 1370 218">Working range: 5 m to 150 m (15 ft to 500 ft). Positioning accuracy: 5 cm at 100 m (1.97" at 330 ft).</p>  <p data-bbox="1020 239 1316 298">a) Flashing red diode b) Flashing yellow diode</p> <p>The diagram illustrates the working range and positioning accuracy of the FlexLine 58. A top-down view of the vehicle shows two flashing diodes: a red diode (a) and a yellow diode (b). The vehicle is positioned 100 m (300 ft) above three human figures. The red diode illuminates a 6 m (20 ft) area on the right, and the yellow diode illuminates a 6 m (20 ft) area on the left. The total width of the illuminated area is 12 m (40 ft).</p> <p data-bbox="710 751 749 761">TSGR_0915</p>

ATMOSPHERIC DATA (PPM)

This screen enables the entry of atmospheric parameters. Distance measurement is influenced directly by the atmospheric conditions of the air in which the measurements are taken. In order to take these influences into consideration distance measurements are corrected using atmospheric correction parameters. The refraction correction is taken into account in the calculation of the height differences and the horizontal distance. Refer to "14.7 Scale Correction" for the application of the values entered in this screen.



When PPM=0 is selected, the Leica standard atmosphere of 1013.25 mbar, 12°C, and 60% relative humidity will be applied.

PROJECTION SCALE

This screen enables entry of the scale of projection. Coordinates are corrected with the PPM parameter. Refer to "14.7 Scale Correction" for the application of the values entered in this screen.

Enter individual PPM

This screen enables the entry of individual scaling factors. Coordinates and distance measurements are corrected with the PPM parameter. Refer to "14.7 Scale Correction" for the application of the values entered in this screen.

EDM SIGNAL REFLECTION

This screen tests the EDM signal strength (reflection strength) in steps of 1%. Enables optimal aiming at distant, barely visible, targets. A percentage bar and a beeping sound, indicate the reflection strength. The faster the beep the stronger the reflection.

4.3 Communication Parameters

Description

For data transfer the communication parameters of the instrument must be set.

Access

1. Select **Settings** from the **MAIN MENU**.
2. Select **Comm** from the **SETTINGS MENU**.

COMM. - PARAMETERS

COMMUNICATION PARAMETER	
Port :	Bluetooth
Bluetooth:	Active
Baudrate :	115200
Databits :	8
Parity :	None
Endmark :	CR
Stopbits :	1
BT-PIN [] [] [] [] OK	

BT-PIN

To set a PIN code for the Bluetooth connection.



This softkey is only available for instruments with a Communication side cover. The default Bluetooth PIN is '0000'.

RESET

To reset the fields to the default Leica standard settings.

Field	Description
Port	Instrument port. If a Communication side cover is fitted the options are selectable. If there is no Communication side cover the value is set to RS232 and is uneditable.
RS232	Communication is via the serial interface.
USB	Communication is via the USB host port.

Field	Description	
	Bluetooth	Communication is via Bluetooth.
	Automatically	Communication is set to auto detect.
Bluetooth	Active	Bluetooth sensor is activated.
	Inactive	Bluetooth sensor is deactivated.

The following fields are active only when **Port: RS232** is set.

Field	Description	
Baudrate		Speed of data transfer from receiver to device in bits per second.
		1200, 2400, 4800, 9600, 14400, 19200, 38400, 57600, 115200
Databits		Number of bits in a block of digital data.
	7	Data transfer is realised with 7 databits.
	8	Data transfer is realised with 8 databits.
Parity	Even	Even parity. Available if data bit is set to 7.
	Odd	Odd parity. Available if data bit is set to 7.
	None	No parity. Available if data bit is set to 8.
Endmark	CR/LF	The terminator is a carriage return followed by a line feed.
	CR	The terminator is a carriage return.
Stopbits	1	Number of bits at the end of a block of digital data.

Leica standard settings

When **RESET** is selected the communication parameters are reset to the default Leica standard settings:

- 115200 Baud, 8 Databit, No Parity, CR/LF Endmark, 1 Stopbit.

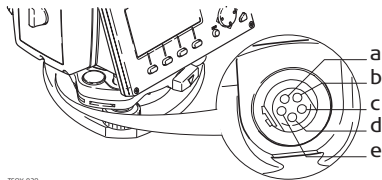
Interface plug connections

TSOK_029

- a) External battery
- b) Not connected / inactive
- c) GND
- d) Data reception (TH_RXD)
- e) Data transfer (TH_TXD)

5

Tools

5.1

Adjust

Description

The **ADJUSTMENTS** menu contains tools to be used for the electronic adjustment of the instrument and for setting adjustment reminders. Using these tools helps to maintain the measuring accuracy of the instrument.

Access

1. Select **TOOLS** from the **MAIN MENU**.
2. Select **Adjust** from the **TOOLS MENU**.
3. Select an Adjustment option from the **ADJUSTMENTS** screen.

Adjustment options

In the **ADJUSTMENT** screen there are several adjustment options.

Menu selection	Description
Hz-Collimation	Refer to "11.3 Adjusting Line-of-Sight and Vertical Index Error".
V-Index	Refer to "11.3 Adjusting Line-of-Sight and Vertical Index Error".
Tilt Axis	Refer to "11.4 Adjusting the Tilting Axis Error".
View Adjustment Data	Displays the current adjustment values that have been set for Hz-Collimation, V-index and Tilt Axis.

Menu selection	Description
Adjust Reminder	Defines the time period from the last adjustment to when a reminder message should display to do another adjustment. Options are: Never, 2 weeks, 1 month, 3 months, 6 months, 12 months. The message will display the next time the instrument is switched on after the time period has been reached.

5.2 Start Up Sequence

Description

Through the Startup tool, it is possible to record a user defined sequence of key presses so that, after switching on the instrument, a particular screen can be displayed after the Level/Plummet screen instead of the **MAIN MENU**. For example, the general **SETTINGS** screen for configuring the instrument settings.

Access

1. Select **TOOLS** from the **MAIN MENU**.
 2. Select **Startup** from the **TOOLS MENU**.
-

Auto start step-by-step

1. Press **RECORD** in the **AUTO START** screen.
2. Press **OK** to confirm the information message and begin the recording process.
3. The next key presses are stored, up to a maximum of 16. To end the recording press **ESC**.
4. If the auto start **Status:** is set to **Active**, the stored key presses will be executed automatically after switching on the instrument.



The automatic start sequence has the same effect as pressing the keys manually. Certain instrument settings can not be made in this way. Relative entries such as automatically setting **EDM mode: Prism-Fast** upon switching on the instrument, are not possible.

5.3 System Information

Description

The System information screens display instrument, system and firmware information, as well as settings for the date and time.

Access

1. Select **Tools** from the **MAIN MENU**.
2. Select **SysInfo** from the **TOOLS MENU**.

SYSTEM INFORMATION

This screen displays information about the instrument and operating system.

SYSTEM INFORMATION 1/2	
Instr. Type:	TS09ultra-1
SerialNo. :	123456
Equip. No. :	-----
RL-Type :	R1000
NextService:	04.08.2009
Date :	04.08.2008
Time :	17:33:13
SOFTW.	DATE
TIME	PREV

SOFTW.

To display details of the firmware package installed on the instrument.

DATE

To change the date and format.

TIME

To change the time.

Next step

Press **SOFTW.** to view the firmware package information.

**SOFTWARE-
INFORMATION**

Before selecting **FORMAT**, to format the internal memory, ensure that all important data is first transferred to a computer. Jobs, formats, codelists, configuration files, uploaded languages and firmware will be deleted by formatting.

Field	Description
Instr. -Firmware	Displays the firmware version number installed on the instrument.
Build No.	Displays the build number of the firmware.
Active Language	Displays the current language and version number selected for the instrument.
EDM-Firmware	Displays the version number of the EDM firmware.
Maintenance End	Displays the end date of the maintenance agreement for the instrument.
 Application Information	Displays a list of the applications available on the instrument. A tick will display in the check box beside each application that is licensed.

5.4

Licence Keys

Description

To fully activate hardware functionality, firmware applications and firmware contracts, licence keys may be required on the instrument. For all instruments, licence keys can be manually entered or uploaded via FlexOffice. For instruments fitted with a Communication side cover licence keys can also be uploaded via a USB memory stick.

Access

1. Select **Tools** from the **MAIN MENU**.
 2. Select **Lic.Key** from the **TOOLS MENU**.
-

Enter licence key

Field	Description
Method	Method of licence key entry. Either Manual Entry or Upload Key File .
Key	Licence key. Available when Method: Manual Entry .



Selecting **DELETE** from this screen will delete all firmware licence keys on the instrument and the firmware maintenance licence.

Next step

IF	THEN
a licence key is manually entered.	OK processes the entry. An acceptance or error message will display depending on the value entered. Both messages require confirmation.

IF	THEN
a licence key is to be uploaded.	OK begins the upload of the licence key file.

5.5

Instrument Protection with PIN

Description

The instrument can be protected by a Personal Identification Number. If PIN protection is activated, the instrument will always prompt for a PIN code entry before starting up. If a wrong PIN has been entered five times, a Personal UnblockKey (PUK) code is required. This can be found on the instrument delivery papers.

Activate PIN code step-by-step

1. Select **TOOLS** from the **MAIN MENU**.
2. Select **PIN** from the **TOOLS MENU**.
3. Activate PIN protection by setting **Use PIN Code: On**.
4. Enter a personal PIN Code (max. 6 numerics) in the **New PIN-Code** field.
5. Accept with **OK**.



Now the instrument is protected against unauthorised use. After switching on the instrument PIN code entry is necessary.

Lock instrument step-by-step

If PIN protection is activated, it is possible to lock the instrument from within any application without switching off the instrument.

1. Press **FNC** when within any application.
2. Select **Lock with PIN** from the **FUNCTIONS** menu.

Entering the PUK code

If a wrong PIN has been entered five times, the system will prompt for a Personal UnblockKey code. The PUK code can be found on the instrument delivery papers. If the PUK code entered is correct then the instrument will start up and reset the PIN code to default value **0** and **Use PIN Code: Off**.

Deactivate PIN code step-by-step

1. Select **TOOLS** from the **MAIN MENU**.
 2. Select **PIN** from the **TOOLS MENU**.
 3. Enter the current PIN in **PIN-CODE:**.
 4. Press **OK**.
 5. Deactivate PIN protection by setting Use **PIN Code: Off**.
 6. Accept with **OK**.
-



The instrument is now no longer protected against unauthorised use.

5.6 Loading Software

Description

To load application software or an additional language, connect the instrument to FlexOffice via the serial interface and load using "FlexOffice - Software Upload". Refer to the FlexOffice online help for further information.

For instruments fitted with a Communication side cover, the software can be loaded via a USB memory stick. This process is described below.

Access

1. Select **Tools** from the **MAIN MENU**.
2. Select **Load FW** from the **TOOLS MENU**.



- **Load FW** is only an option on the **TOOLS MENU** for those instruments fitted with a Communication side cover.
- Never disconnect the power supply during the system upload process. The battery must be at least 75% capacity before commencing the upload.

Loading firmware and languages step-by-step

1. To load firmware and languages: Select **Firmware**. The **Select File** screen will appear.
To load only languages: Select **Languages only** and skip to step 4.
2. Select the firmware file from the system folder of the USB memory stick. All firmware and language files must be stored in the system folder to be transferred to the instrument.
3. Press **OK**.

4. The **Upload Languages** screen will appear displaying all language files in the system folder of the USB memory stick. Select **Yes** or **No** for a language file to be uploaded. At least one language must be set to **Yes**.
 5. Press **OK**.
 6. Press **Yes** on the power warning message to proceed and upload the firmware and/or selected languages.
 7. Once successfully loaded, the system will shutdown and restart again automatically.
-

6



Functions

6.1

Overview

Description

Functions can be accessed by pressing **FNC**,  or  from any measurement screen.

- **FNC** opens the functions menu and a function can be selected and activated.
-  or , activates the specific function assigned to the key. Any function from the function menu can be assigned to these keys. Refer to "4.1 General Settings".

Functions

Function	Description
Level/Plummet	Activates the laser plummet and electronic level.
Offset	Refer to "6.2 Target Offset".
Non-Prism/Prism Toggle	Changes between the two EDM modes. Refer to "4.2 EDM Settings".
Delete Last Record	Deletes the last recorded data block. This can be either a measurement block or a code block.  Deleting the last record is not reversible! Only records recorded in Surveying can be deleted.
Height transfer	Refer to "6.3 Height Transfer".
Hidden point	Refer to "6.4 Hidden Point".

Function	Description
Free Coding	Starts Coding application to select a code from a codelist or enter a new code. Same functionality like the softkey CODE .
Laserpointer	Activates/deactivates the visible laser beam for illuminating the target point.
Main Menu	Returns to the MAIN MENU .
Display-Light On /Off	Activates and deactivates the display illumination light.
Distance unit	Sets the distance measurement unit.
Angle unit	Sets the angle measurement unit.
Lock with PIN	Refer to "5.5 Instrument Protection with PIN".
Check Tie	Refer to "6.5 Check Tie".
Main settings	Refer to "4.1 General Settings".
EDM Tracking	Refer to "6.6 EDM Tracking".

6.2 Target Offset

6.2.1 Overview

Availability

TS02 ✓

TS06 ✓

TS09 ✓

Description

This function calculates the target point coordinates if it is not possible to set up the reflector, or to aim at the target point directly. The offset values (length, trav. and/or height offset) can be entered. The values for the angles and distances are calculated to determine the target point.

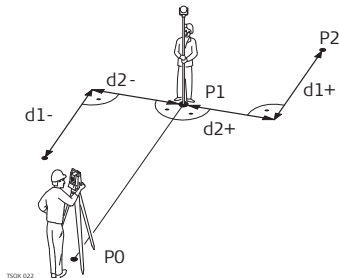

- P0 Instrument station
- P1 Measured point
- P2 Calculated offset point
- d1+ Length offset, positive
- d1- Length offset, negative
- d2+ Trav. offset, positive
- d2- Trav. offset, negative

Access

1. Press FNC when within any application.
2. Select Offset from the **FUNCTIONS** menu.

Enter offset values

Enter offset values!		
Trav. Offset:	2.000 m	
Length Offset:	0.000 m	
Height Offset:	0.000 m	
Mode	Reset after REC (↔)	
RESET	CYLNDER	OK

RESET

To reset offset values to 0.

CYLNDER

To enter cylindrical offsets.

Field	Description
Trav. Offset	Perpendicular offset. Positive if the offset point is to the right of the measured point.
Length Offset	Longitudinal offset. Positive if the offset point is further away than the measured point.
Height Offset	Height offset. Positive if the offset point is higher than the measured point.
Mode	Period for which the offset is to apply. Reset after REC The offset values are reset to 0 after the point is saved. Permanent The offset values are applied to all further measurements.

Field	Description
	The offset values are always reset to 0 when the application is quit.

Next step

- Either, press **OK** to calculate the corrected values and return to the application from which the offset function was started. The corrected angle and distances are displayed as soon as a valid distance measurement has been triggered or exists.
- Or, press **CYLINDER** to enter cylindrical offsets. Refer to "6.2.2 Cylinder Offset Subapplication".

6.2.2**Cylinder Offset Subapplication****Availability****TS02** ✓**TS06** ✓**TS09** ✓**Description**

Determines the coordinates of the center point of cylindrical objects and their radius. The horizontal angle to points on both the left and right sides of the object are measured, and the distance to the object as well.

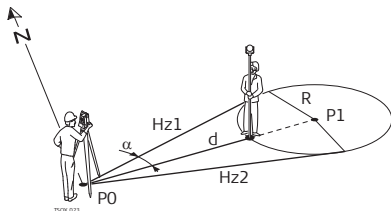

- P0 Instrument station
 P1 Center point of cylindrical object
 Hz1 Horizontal angle to a point on the left side of the object
 Hz2 Horizontal angle to a point on the right side of the object
 d Distance to the object in the middle between Hz1 and Hz2
 R Radius of cylinder
 α Azimuth from Hz1 to Hz2

Access

Press **CYLINDER** from Target Offset **Enter offset values.**

CYLINDRICAL OFFSET

CYLINDRICAL OFFSET		
Hz Left	: 52.0000 g	
Hz Right	: 95.0000 g	
	: ----- m	P
Δ Hz	: ← -21.5000 g	
PrismOffset:	0.000 m	
HzLeft	HzRight	ALL
		↓

HzLeft

To trigger measurement for the left side of the object.

HzRight

To trigger measurement for the right side of the object.

Field	Description
Hz Left	Measured horizontal direction to the left side of the object. Using the vertical hair, aim at the left side of the object, then press HzLeft .
Hz Right	Measured horizontal direction to the right side of the object. Using the vertical hair, aim at the right side of the object, then press HzRight .
	Slope distance to the reflector.
ΔHz	Deviation angle. Rotate the instrument to aim in the direction of the center point of the cylindrical object, such that Δ Hz is zero.
Prism Offset	Prism offset distance between the center of the prism and the surface of the object to be measured. If the EDM mode is Non-Prism, the value is set to zero automatically.

Next step

Once **Δ Hz:** is zero, press **ALL** to complete the measurement and display the results.

CYLINDRICAL OFFSET RESULT

CYLINDRICAL OFFSET RESULT	
PtID :	P405
Desc :	-----
East :	33.860 m
North :	14.970 m
Height:	9.016 m
Radius:	12.267 m
FINISH	NEW

FINISH

To record results and return to **Enter offset values** screen.

NEW

To measure a new cylindrical object.

Field	Description
PtID	Defined point ID of the center point.
Desc	Description of the center point if desired.
East	Easting coordinate of the center point.
North	Northing coordinate of the center point.
Height	Height of the point measured with the reflector.  This is not the calculated height of the center point.
Radius	Radius of the cylinder.

Next step

Press **FINISH** to return to the **Enter offset values** screen. From the **Enter offset values** screen, press **OK** to return to the application where **FNC** was selected.

6.3

Height Transfer

Availability

TS02 ✓

TS06 ✓

TS09 ✓

Description

This function determines the height of the instrument from measurements to a maximum of five target points, with known heights, in two faces. With measurements to several targets, the improvement is indicated in the "Δ" value.

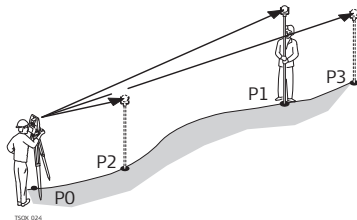

P0 Instrument station
 P1 to P3 Target points of known heights

Access

1. Press **FNC** when within any application.
2. Select **Height Transfer** from the **FUNCTIONS** menu.

Height transfer
step-by-step

1. Select a known point and input the reflector height
 - **PtHgt**: To enter the height of a fixpoint.
 - **hi**: To enter the height transfer values for the instrument.
2. Press **ALL** to complete the measurement and display the calculated height H0.

- **AddTg**: Adds another height of a known point.
- **FACE**: Measures to the same target in second face.
- **OK**: Saves the changes and sets the station height.

6.4

Hidden Point

Availability

TS02 ✓

TS06 ✓

TS09 ✓

Description

This function is used for measurements to a point that is not directly visible, using a special hidden point rod.

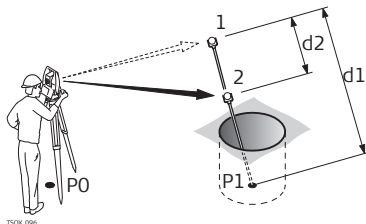

- P0 Instrument station
 P1 Hidden point
 1-2 Prisms 1 and 2
 d1 Distance between prism 1 and the hidden point
 d2 Distance between prism 1 and 2

Access

1. Press **FNC** when within any application.
2. Select **Hidden Point** from the **FUNCTIONS** menu.

Next step

If required, press **ROD/EDM** to define the rod or EDM settings.

Functions

FlexLine, 81

ROD SETTINGS

Field	Description
EDM-Mode	Changes the EDM Mode.
Prism type	Changes the prism type.
Prism Const	Displays the prism constant.
Rod Length	Total length of hidden point rod.
Dist. R1-R2	Spacing between the centers of the prisms R1 and R2.
Meas. Tol	Limit for the difference between the given and measured spacing of the prisms. If the tolerance value is exceeded, the function will issue a warning.

Next step

In the **HIDDEN POINT** screen, measure to the first and second prisms using **ALL** and the **HIDDEN POINT RESULT** screen is displayed.

HIDDEN POINT RESULT

Displays Easting, Northing and Height coordinates of the hidden point.

HIDDEN POINT RESULT	
PtID :	P408
Desc :	-----
East :	21.551 m
North :	10.141 m
Height:	11.865 m
FINISH	NEW

FINISH

To record results and return to application where **FNC** was selected.

NEW

To return to the **HIDDEN POINT** screen.

Next step

Press **FINISH** to return to the application where **FNC** was selected.

6.5

Check Tie

Availability



TS02 ✓**TS06** ✓**TS09** ✓

Description

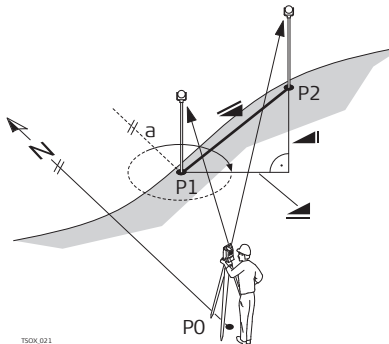
This function calculates and displays the slope and horizontal distance, height difference, azimuth, grade, and coordinate differences between the last two measured points. Valid distance measurements are required for the calculation.





TS09_021

- a Azimuth
-  Slope distance
-  Height distance
-  Horizontal distance
- P0 Instrument station
- P1 First point
- P2 Second point

Access

1. Press **FNC** when within any application.
2. Select **Check Tie** from the **FUNCTIONS** menu.

CHECK TIE

Field	Description
Bearing	Difference in bearing between the two points.
Grade	Difference in gradient between the two points.
	Difference in horizontal distance between the two points.
	Difference in slope distance between the two points.
Δ 	Difference in height between the two points.
Δ East	Difference in Easting coordinate between the two points.
Δ North	Difference in Northing coordinate between the two points.
Δ Height	Difference in the height coordinate between the two points.

Messages

The following are important messages or warnings that may appear.

Messages	Description
Less than two valid measurements!	The values cannot be calculated as there are less than two valid measurements.

Next step

Press **OK** to return to the application where **FNC** was selected.

6.6

EDM Tracking

Description

This function activates or deactivates the tracking measurement mode. The new setting is displayed for about one second and then set. The function can only be activated from within the same EDM mode and prism type. The following options are available.

EDM Mode	Tracking measurement mode Off <=> On
Prism	Prism-Standard <=> Prism-Tracking / Prism-Fast <=> Prism-Tracking.
Non-Prism	Non-Prism-Standard <=> Non-Prism-Track.



The last active measurement mode remains set when the instrument is switched off.

7

Coding

7.1

Standard Coding

Description

Codes contain information about recorded points. With the help of coding, points can be assigned to a particular group simplifying later processing.

GSI coding

Codes are always stored as free codes (WI41-49), that means that codes are not directly linked to a point. They are stored before or after the measurement depending on the setting made. Point codes (WI71-79) are not available. A code is always recorded for each measurement as long as the code is displayed in the **Code:** field. For a code not to be recorded, the **Code:** field must be cleared. This can be set to occur automatically. Refer to "4.1 General Settings".

Access

- Either, select **Q-Survey** from the **MAIN MENU** and press **↓ CODE**.
- Or, press **FNC** when within any application and select **Free Coding**.

CODING

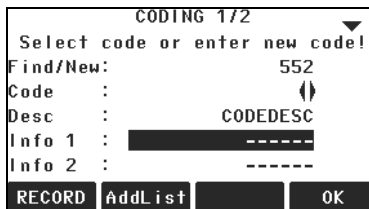

RECORD

To record the code without measurement.

AddList

To add the entered code to the codelist.

Field	Description
Find/New	Code name. After entry, the firmware searches for a matching code name, and displays these in the code field. If a matching code name doesn't exist this value becomes the new code name.
Code	List of existing code names.
Desc.	Additional remarks.
Info1 to Info8	More information lines, freely editable. Used to describe attributes of the code.

Extend / edit codes

To each code a description and a maximum of 8 attributes with up to 16 characters each can be assigned. Existing code attributes, displayed in fields **Info 1:** to **Info 8:**, can be overwritten freely with the following exceptions:

The codelist editor of FlexOffice can assign a status to the attributes.

- Attributes with status "fixed" are write-protected. They cannot be overwritten or edited.
 - For attributes with status "Mandatory" an input or a confirmation is required.
 - Attributes with status "Normal" can be edited freely.
-

7.2

Quick Coding

Availability

TS02 -

TS06 ✓

TS09 ✓

Description

Using the quick code function, a predefined code can be called directly via the keypad on the instrument. The code is selected by entering a two digit number, the measurement is then triggered and the measured data and code saved.

A total of 99 quick codes can be assigned.

The quick code number is assigned in accordance with the order in which the codes were entered, for example, 01 -> first code in the code list ... 10 -> tenth code in the code list. Alternatively each code can be assigned a unique one or two digit number in the Codelist Manager in FlexOffice.

Access

1. Select **Prog** from the **MAIN MENU**.
2. Select **Surveying** from the **PROGRAMS** menu.
3. Select **Start**
4. Press ↓ **Q-CODE**

Quick coding step-by-step

1. Press ↓ **Q-CODE**.
2. Enter a two digit number on the keypad.



A two digit code must always be entered on the keypad even if only a one digit code was assigned in the Codelist Manager.

For example: 4 -> enter 04.

3. The code is selected, the measurement triggered and the measured data and code saved. The name of the selected code is displayed after the measurement.
4. Press ↓ **Q-CODE** again to end quick coding.

Messages

The following are important messages or warnings that may appear.

Messages	Description
Attrib. cannot be changed !	Attribute with fixed status cannot be changed.
No codelist available !	No codelist in memory. Manual input for code and attributes are called automatically.
Code not found !	No code is assigned to the entered number.

FlexOffice

Codelists can be easily created and uploaded to the instrument using the supplied FlexOffice software.

8 Applications - Getting Started

8.1 Overview

Description

Applications are predefined programs, that cover a wide spectrum of surveying duties and facilitate daily work in the field. The following applications are available, although application packages for each FlexLine instrument may vary from that stated below:

Application	TS02	TS06	TS09
Surveying	✓	✓	✓
Stakeout	✓	✓	✓
Free Station	✓	✓	✓
Reference Line	✓	✓	✓
Reference Arc	Optional	✓	✓
Tie Distance	✓	✓	✓
Area & Volume	✓	✓	✓
Remote Height	✓	✓	✓
Construction	✓	✓	✓
COGO	Optional	✓	✓
Reference Plane	Optional	✓	✓
Road 2D	Optional	✓	✓

Application	TS02	TS06	TS09
Roadworks 3D	Not available	Optional	✓
TraversePRO	Not available	Optional	✓



Only softkeys unique to the applications are explained in the application chapters. Refer to "2.4 Softkeys" for descriptions of the common softkeys.

8.2

Starting an Application

Access

1. Select **Prog** from the **MAIN MENU**.
2. Press  to move through the screens of available applications.
3. Press a function key, **F1 - F4**, to select the specified application in the **PROGRAMS** menu.

Pre-settings screens

Pre-settings for Surveying is shown as an example. Any additional settings for particular applications are explained within the chapters for those applications.

SURVEYING			
[•]	F1	Set Job	(1)
[•]	F2	Set Station	(2)
[]	F3	Set Orientation	(3)
	F4	Start	(4)
F1		F2	
F3		F4	

[•] = Setting has been made.
 [] = Setting has not been made.

F1-F4
 To select menu item.

Field	Description
Set Job	To define the job where data will be saved. Refer to "8.3 Setting the Job".
Set Station	To define the current position of the instrument station. Refer to "8.4 Setting the Station".
Set Orientation	To define the orientation, horizontal direction, of the instrument station. Refer to "8.5 Setting the Orientation".
Start	Starts the selected application.

8.3 Setting the Job

Description

All data is saved in Jobs, like file directories. Jobs contain measurement data of different types, for example measurements, codes, fixed points, or stations. Jobs are individually manageable and can be exported, edited or deleted separately.

Access

Select **Set Job** in **Pre-settings** screen.

SELECT JOB

SELECT JOB		3/5
Job :	<input type="text" value="J101"/>	↔
Operator:	SJ100	
Date :	04. 08. 2008	
Time :	15:36:44	
<input type="button" value="NEW"/>		<input type="button" value="OK"/>

NEW

To create a new job.

Field	Description
Job	Name of an existing job to be used.
Operator	Name of operator, if entered.
Date	Date the selected job was created.
Time	Time the selected job was created.

Next step

- Either, press **OK** to continue with the selected job.
 - Or, press **NEW** to open the **NEW JOB** screen and create a new job.
-

Recorded data

Once a job is set up, all subsequent recorded data will be stored in this job. If no job was defined and an application was started, or if in **Q-Survey** and a measurement was recorded, then the system automatically creates a new job and names it "DEFAULT".

Next step

Press **OK** to confirm the job and return to the **Pre-Settings** screen.

8.4**Setting the Station**

Description

All measurements and coordinate computations are referenced to the set station coordinates.

The station coordinates that are set must include:

- at least grid coordinates (E, N), and
- the station height, if required.

The coordinates can be entered manually or selected from the memory.

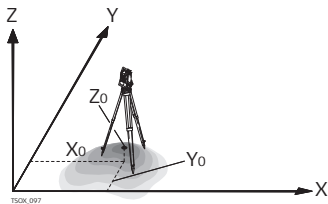
**Directions**

- X Easting
- Y Northing
- Z Height

Station coordinates

- X0 Easting coordinate of station
- Y0 Northing coordinate of station
- Z0 Height of station

Access

Select **Set Station** in the **Pre-settings** screen.

Set Station

Field	Description
Station	Station name of a previously saved station position.
hi	Height of the instrument from the ground surface.

**Next step**

If no station was set and an application was started, or if in **Q-Survey** and a measurement was recorded, then the last station is set as the current station.

The **Enter instrument height** screen appears once the station coordinates have been entered. Enter the instrument height if desired and press **OK** to return to the **Pre-Settings** screen.

8.5

Setting the Orientation

8.5.1

Overview

Description

All measurements and coordinate computations are referenced to the orientation of the set station. The orientation can be entered manually or determined from points that are either measured or selected from the memory.

Access

Select **Set Orientation** in the **Pre-settings** screen and choose:

- **Manual Angle Setting** To enter a new bearing. Refer to "8.5.2 Manual Orientation".
 - **Coordinates** To calculate and set the orientation using existing coordinates. A maximum of five target points can be used. Refer to "8.5.3 Orientation with Coordinates".
-

8.5.2 Manual Orientation

Access

Select **Manual Angle Setting** in the **ORIENTATION** screen.

MANUAL ANGLE SETTING

MANUAL ANGLE SETTING	
Bearing:	0.0000 g
hr :	1.500 m
BS ID :	301
Aim at target and press ALL/REC	
ALL	REC
Hz=0	EDM

Hz=0

To set **Bearing: 0**

Field	Description
Bearing	Horizontal direction of the station.
hr	Height of the reflector.
BS ID	Point ID of the backsight point.

Next step

- Either, press **ALL** to measure and record the distance and horizontal angles. This will calculate and set the orientation and return to the **Pre-Settings** screen.
- Or, press **REC** to record the horizontal direction only. This will set the orientation and return to the **Pre-Settings** screen.

8.5.3

Orientation with Coordinates

Diagram

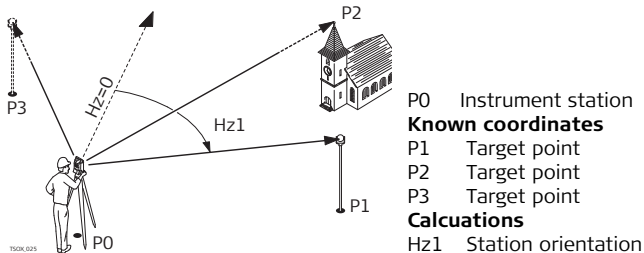

Access

Select **Coordinates** in the **ORIENTATION** screen.

Orientation with coordinates



Field	Description
BS ID	Point ID of the backsight point.

Next step

Find an existing backsight point in the pointsearch or enter ENH coordinates for a new point. Press **OK** to continue to **Sight target point**.

Sight target point

Field	Description
BS ID	Point ID of the selected, or entered backsight point.

Field	Description
hr	Height of the reflector.
Hz	Horizontal direction to the target point.
Azimuth	Azimuth to the target point.
	The horizontal distance to the target point.
	The vertical distance to the target point.  After the first measurement the finding of other target points (or the same point when changing faces) is easier by turning the instrument to set the indicated angle difference near to 0°00'00".
1/I	Status indication. Shows that the first point was measured in face I.
1/I II	Status indication. Shows that the first point was measured in faces I and II.

Next step

After each measurement the message, **Do you want to take additional measurements** appears. Selecting:

- **Yes** returns to the **Sight target point** screen to take an additional measurement. A maximum of five target points can be used.
- **No** proceeds to the **ORIENTATION RESULT** screen.

Result calculation

If more than one target point is measured then the orientation is computed using the "least squares method".

IF	THEN
the orientation is only measured in face II	the horizontal direction is based on face II.
the orientation is measured only in face I or a mixture of I and II	the horizontal direction is based on face I.
a target point is measured several times in the same face	the last valid measurement is used for the computation.

Orientation results

Field	Description
Pts	Number of points used in the calculation.
Station	Station name for which the orientation has been set.
Hz Corr	Horizontal correction
Std. Dev.	Standard deviation indicating the potential variance between the true orientation and that calculated.

Next step

- Either, press **Resid** to display the residuals.
- Or, press **OK** to set the orientation and return to the **Pre-Settings** screen.

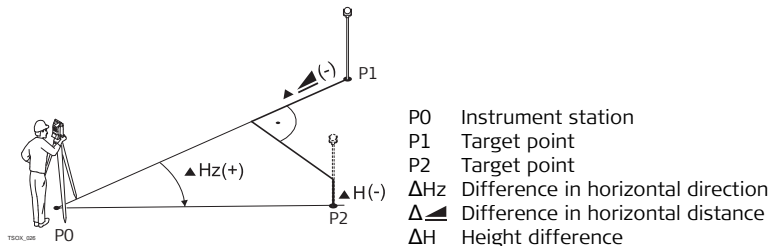
Orientation
residuals

Field	Description
BS ID	Point IDs of the target points used in calculating the orientation.
ΔH_z	The difference in horizontal direction to the target point.
Δ	The difference in horizontal distance to the target point.
Δ Height	The difference in height to the target point.



If no orientation was set and an application was started, or if in **Q-Survey** and a measurement was recorded, then the current horizontal direction is set as the orientation.

Next step

Select **Start** to begin the application.

9



9.1

Description of fields

Applications

Common Fields

The following table describes common fields that are found within the firmware applications. These fields are described here once and not repeated in the application chapters unless the field has a specific meaning within that application.

Field	Description
PtID, Point, Point 1	Point ID of the point.
hr	Height of the reflector.
Hz	Horizontal direction to the point.
V	Vertical angle to the point.
	Horizontal distance to the point.
	Slope distance to the point.
	Height to the point.
East	Easting coordinate of the point.
North	Northing coordinate of the point.
Height	Height coordinate of the point.

9.2 Surveying

Availability

TS02 ✓

TS06 ✓

TS09 ✓

Description

Surveying is an application used for the measurement of an unlimited number of points. It is comparable to **Q-Survey** from the **MAIN MENU**, but includes pre-settings for the job, station and orientation prior to beginning a survey.

Access

1. Select **Prog** from the **MAIN MENU**.
2. Select **Surveying** from the **PROGRAMS** menu.
3. Complete application pre-settings. Refer to "8 Applications - Getting Started".

SURVEYING

SURVEYING 1/3		
PtID	: P401	
hr	: 1.500 m	
Code	: 552	
Hz	: 25.7000 g	
V	: 83.2300 g	
	: 25.103 m	
<div style="display: flex; justify-content: space-around;"> ALL DIST REC ↓ </div>		

↓ IndividPt

To switch between individual and current point numbers.

↓ DATA

To view measurement data.

↓ CODE

To find/enter codes. Refer to "7.1 Standard Coding".

↓ Q-CODE

To activate quick coding. Refer to "7.2 Quick Coding".

Field	Description
Remark / Code	<p>Remark or Code name depending on the coding method. Three coding methods are available:</p> <ol style="list-style-type: none"> 1. Remark coding: This text is stored with the corresponding measurement. The code is not related to a codelist, it is just a simple remark. A codelist on the instrument is not necessary. 2. Expanded coding with codelist: Press ↓ CODE. The code that was entered is searched for within the code list and it is possible to add attributes to the code. The field name will change to Code:. 3. Quick coding: Press ↓ Q-CODE and enter the shortcut to the code. The code is selected and the measurement starts. The field name will change to Code:.

Next step

- Either, press **ALL** to record another point.
- Or, press **ESC** to exit the application.

9.3

Stakeout

Availability

TS02 ✓

TS06 ✓

TS09 ✓

Description

Stakeout is an application used to place marks in the field at predetermined points. These predetermined points are the points to be staked. The points to be staked may already exist in a job on the instrument, or be manually entered.

The application can continuously display differences, between current position and desired stake out position.

Stakeout modes

Points can be staked using different modes: Polar mode, Orthogonal to station mode and Cartesian mode.

Polar Stakeout mode

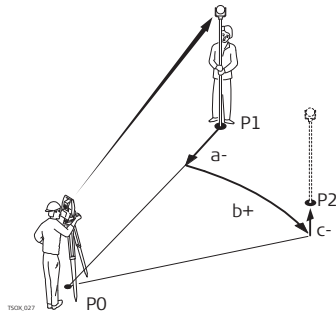

- P0 Instrument station
- P1 Current position
- P2 Point to be staked
- a- Δ : Difference in horizontal distance
- b+ Δ Hz: Difference in direction
- c+ Δ : Difference in height

Orthogonal to Station Stakeout mode

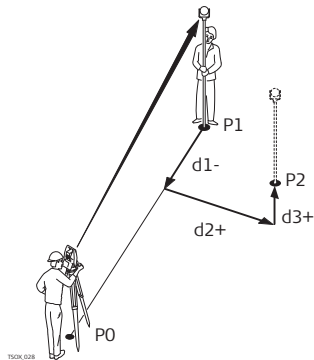

- P0 Instrument station
- P1 Current position
- P2 Point to be staked
- d1- Δ Length: Difference in longitudinal distance
- d2+ Δ Trav: Difference in perpendicular distance
- d3+ Δ Height: Difference in height

Cartesian Stakeout mode

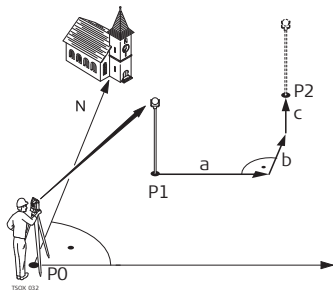

P0 Instrument station

P1 Current position

P2 Point to be staked

a Δ East: Difference in Easting coordinate

b Δ North: Difference in Northing coordinate

c Δ Height: Difference in height

Access

1. Select **Prog** from the **MAIN MENU**.
2. Select **STAKEOUT** from the **PROGRAMS** menu.
3. Complete application pre-settings. Refer to "8 Applications - Getting Started".

STAKEOUT

STAKEOUT 1/3	
Search :	*
PtID :	P401
Type :	Meas.
hr :	1.500 m
Δ Hz :	← -0.3000 g
Δ ↗ :	↑ 0.348 m
Δ ↘ :	↓ -0.846 m
ALL DIST REC ↓	

MANUAL

To manually enter coordinates of a point.



↓ B&D

To enter the direction and horizontal distance to a stake out point.



Press  to move through the pages. The bottom three measurement fields on the screen will change for the Polar, Orthogonal or Cartesian modes.

Field	Description
Search	Value for Point ID search. After entry, the firmware searches for matching points, and displays these in PtID : If a matching point doesn't exist the pointsearch screen opens.
Type	Displays the type of point selected. <ul style="list-style-type: none">• Measured, or• Fixpoint
Δ Hz	Angle offset: Positive if stake out point is to the right of the measured point.

Field	Description
Δ 	Horizontal offset: Positive if stake out point is further away than the measured point.
Δ 	Height offset: Positive if stake out point is higher than the measured point.
Δ Length	Longitudinal offset: Positive if stake out point is further away than the measured point.
Δ Trav.	Perpendicular offset: Positive if stake out point is to the right of the measured point.
Δ Height	Height offset: Positive if stake out point is higher than the measured point.
Δ East	Easting offset: Positive if stake out point is to the right of the measured point.
Δ North	Northing offset: Positive if stake out point is further away than the measured point.
Δ Height	Height offset: Positive if stake out point is higher than the measured point.

Next step

- Either, press **ALL** to record measurements for a stake out point.
- Or, press **ESC** to exit the application.

9.4

9.4.1

Free Station Starting Free Station

Availability

TS02 ✓ 5 points

TS06 ✓ 10 points

TS09 ✓ 10 points

Description

Free Station is an application used to determine the instrument's position from measurements to known points. A minimum of two known points can be used to determine the position and a maximum of 5 or 10 known points.

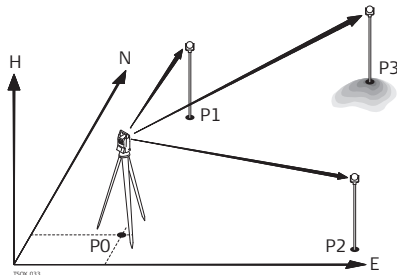

P0 Instrument station
P1 Known point
P2 Known point
P3 Known point

Access

1. Select **Prog** from the **MAIN MENU**.
2. Select **Free Station** from the **PROGRAMS** menu.
3. Complete application pre-settings. Refer to "8 Applications - Getting Started".

4. Set Accuracy Limit:

- **Status: On** to activate a warning message if the calculated standard deviation exceeds the limit.
- Set the accuracy limits for the Easting, Northing and Height coordinates and the standard deviation angle.
- Press **OK** to save the limits and return to the **Pre-settings** screen.

5. Select **Start** to begin the application.

Enter target data

Enter the name of the station and the height of the instrument in the **Enter station data** screen and press **OK**.

Next step

To access the **Sight target point** screen:

- Either, press **OK** after entering the target data fields.
 - Or, press **↓ SKIP** to skip entering the target data fields again when measuring the same point in another face.
-

Sight target point

In the **Sight target point** screen:

2 / I: Indicates that the second point was measured in face I.

2 / I II: Indicates that the second point was measured in faces I and II.

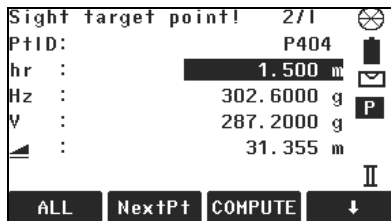

COMPUTE

To calculate and display the station coordinates, if at least two points and a distance were measured.

NextPt

To return to the **Enter target data** screen to select the next known point.

Next step

- Either, press **NextPt** to measure the next known point.
- Or, press **COMPUTE** to calculate the station position.

9.4.2

Measurement sequences

Measuring Information

The following measurement sequences are possible:

- Horizontal direction and vertical-angles only (resection)
- Distance and horizontal direction and vertical-angle
- Horizontal direction and vertical-angles to some point(s) and horizontal direction and vertical angles plus distance to other point(s).

Single face I, single face II, or dual face I and II measurements are always possible. No specific point sequence or specific face sequences are required.

Dual face measurements

When measuring the same target in both faces, the reflector height may not be changed when observing in the second face. Error checks are made for dual face measurements to ensure the same point is sighted with the other face.

- If a target point is measured several times in the same face the last valid measurement is used for computation.
- For the calculation of the station position, measured target points can be re-measured, included in calculations, or excluded from calculations.

Measurements not included in computations

Target points with 0.000 height are discarded for height processing. If a target point has a valid height of 0.000 m, use 0.001 m to include it for height processing.

9.4.3**Computation Procedure****Description**

The measuring procedure automatically determines the method of evaluation, for example resection or three point resection.

If more than the minimum required measurements are performed, the procedure uses a least squares adjustment to determine the 3D position and averages orientation and height measurements.

- The original averaged face I and face II measurements are used for the computation process.
- All measurements are treated with the same accuracy, whether these are measured in single or dual face.

- Easting and Northing are determined by the least squares method, which includes standard deviation and improvements for horizontal direction and horizontal distances.
 - The final height (H) is computed from averaged height differences based on the original measurements.
 - The horizontal direction is computed with the original averaged face I and face II measurements and the final computed plan position.
-

9.4.4

Free Station Results

Access

Press **COMPUTE** from the **Sight target point** screen after at least two points and a distance have been measured.

STATION COORDINATES

This screen displays calculated station coordinates. The final computed results are Easting, Northing and Height coordinates of the present instrument station, including the instrument height.
Standard deviations and residuals for accuracy assessments are provided.

STATION COORDINATES	
Station:	S101
hi :	1.400 m
EO :	-0.000 m
NO :	-0.000 m
HO :	0.000 m
PREV	RESID
Std.Dev	OK

RESID

To display residuals. Refer to "Target Residuals".

StdDev

To display the standard deviation of the coordinates and angle.



If the instrument height was set to 0.000 in the setup screen, then the station height refers to the height of the tilting axis.

Next step

Press **RESID** to display the target residuals.

Target Residuals

The **TARGET RESIDUALS** screen displays the computed residuals for the horizontal and vertical distances and the horizontal direction. Residual = Calculated value - Measured value.

Messages

The following are important messages or warnings that may appear.

Messages	Description
Selected point has no valid data!	This message occurs if the selected target point has no Easting or Northing coordinate.

Messages	Description
Max 5/10 points supported!	5/10 points have already been measured and another point is selected. The system supports a maximum of 10 points for TS06 TS09 and 5 points for TS02 .
Invalid data - no position computed!	The measurements may not allow final station coordinates (Eastings, Northings) to be computed.
Invalid data - no height computed!	Either the target height is invalid or insufficient measurements are available to compute a final station height.
Hz (I - II) > 0.9 deg, measure point again!	This error occurs if a point was measured in one face and the measurement in the other face differs by more than $180^\circ \pm 0.9^\circ$ for the horizontal angle.
V (I - II) > 0.9 deg, measure point again!	This error occurs if a point was measured in one face and the measurement in the other face differs by more than $360^\circ - V \pm 0.9^\circ$ for the vertical angle.
More points or distance required!	There is insufficient data measured to be able to compute a position. Either there are not enough points used or not enough distances measured.

Next step

Press **OK** to return to the **PROGRAMS** menu.

9.5 Reference Element - Reference Line

9.5.1 Overview

Availability**TS02** ✓**TS06** ✓**TS09** ✓

Description

Reference element is an overarching name for the two reference applications, Reference Line and Reference Arc.

Reference Line is an application that facilitates the easy stake out or checking of lines, for example, for buildings, sections of road, or simple excavations. It allows the user to define a reference line and then complete the following tasks with respect to that line:

- Line & offset
 - Stake out points
 - Grid stake out
 - Line segmentation stake out
-

Access

1. Select **Prog** from the **MAIN MENU**.
 2. Select **Reference Element** from the **PROGRAMS** menu.
 3. Complete application pre-settings. Refer to "8 Applications - Getting Started".
 4. Select **RefLine**
-

Next step

Define the base line for the reference line.

9.5.2

Defining the Base Line

Description

A reference line can be defined by referencing a known base line. The reference line can be offset either longitudinally, in parallel or vertically to the base line, or be rotated around the first base point as required. Furthermore the reference height can be selected as the first point, second point or interpolated along the reference line.

Define the base line

The base line is fixed by two base points. All points can be either measured, manually entered, or selected from the memory.

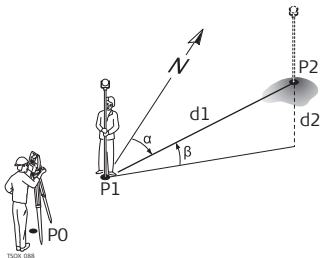

Base line

- P0 Instrument station
- P1 Start point
- P2 End point
- d1 Known distance
- d2 Difference in height
- α Azimuth
- β Elevation angle between the start and end points

Define the base line by measuring or selecting the start and end points of the line.

Next step

After defining the base line the **REFERENCE LINE - MAIN** screen will appear for defining the reference line.

9.5.3 Defining the Reference Line

Description

The base line can be offset from, either longitudinally, in parallel or vertically, or be rotated around the first base point. This new line created from the offsets is called the reference line. All measured data refers to the reference line.

Reference line

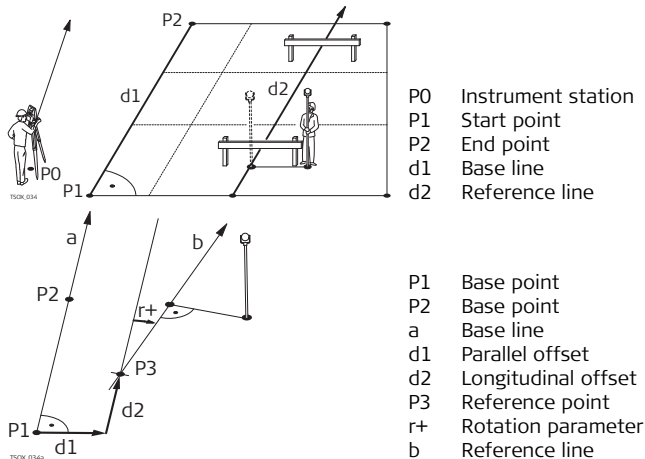

Access

After completing the measurements required for defining the base line, the **REFERENCE LINE - MAIN** screen will appear.

REFERENCE LINE - MAIN

REFERENCE LINE - MAIN 1/2	
Length :	35.497 m
Enter values to shift line	
Offset :	0.250 m
Line :	1.580 m
Height :	0.000 m
Rotate :	0.0000 g
GRID MEASURE STAKE ↓	

GRID

To stake out a grid relative to the reference line.

MEASURE

To measure Line & Offset.

STAKE

To stake out points orthogonal to the reference line.

↓ NewBL

To define a new base line.

↓ SHIFT=0

To reset all offset values to 0.

↓ SEGMENT

To subdivide a reference line into a definable number of segments and stake out the new points on the reference line.

Field	Description
Length	Length of the base line.

Field	Description
Offset	Parallel offset of the reference line relative to the base line (P1-P2). Positive values are to the right of the base line.
Line	Longitudinal offset of the start point, reference point (P3), of the reference line in the direction of base point 2. Positive values are towards base point 2.
Height	Height offset of the reference line to the selected reference height. Positive values are higher than the selected reference height.
Rotate	Rotation of the reference line clockwise around the reference point (P3).
Ref.Hgt	<p>Point 1 Height differences are computed relative to the height of the first reference point.</p> <p>Point 2 Height differences are computed relative to the height of the second reference point.</p> <p>Interpolated Height differences are computed along the reference line.</p> <p>No Height Height differences are not computed or shown.</p>

Next step

Select a softkey option, **MEASURE**, **STAKE**, **GRID** or **↓SEGMENT**, to proceed a subapplication.

9.5.4

Subapplication Measure Line & Offset

Description

The Measure Line & Offset subapplication calculates from measurements or coordinates, longitudinal offsets, parallel offsets and height differences of the target point relative to the reference line.



- | | |
|----|--------------------|
| P0 | Instrument station |
| P1 | Start point |
| P2 | End point |
| P3 | Measured point |
| P4 | Reference point |
| d1 | Δ Offset |
| d2 | Δ Line |
-

Example of height difference relative to first reference point

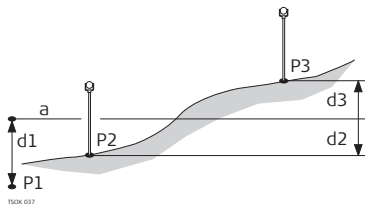

- P1 Start point
- P2 Target point
- P3 Target point
- a Reference height
- d1 Height difference between start point and the reference height
- d2 Height difference between P2 and the reference height
- d3 Height difference between P3 and the reference height

Access

Press **MEASURE** in the **REFERENCE LINE - MAIN** screen.

Measure line & offset

Field	Description
Δ Line	Calculated distance longitudinal to the reference line.
Δ Offset	Calculated distance perpendicular from the reference line.
Δ	Calculated height difference relative to the defined reference height.



Next step

- Either, press **ALL** to measure and record.
- Or, press **↓ PREV** to return to the **REFERENCE LINE - MAIN** screen.

9.5.5

Subapplication Stakeout

Description

The stakeout subapplication calculates the difference between a measured point and the calculated point. The orthogonal (Δ Line, Δ Offset, Δ ) and polar (Δ H_z, Δ , Δ ) differences are displayed.

Example orthogonal stakeout

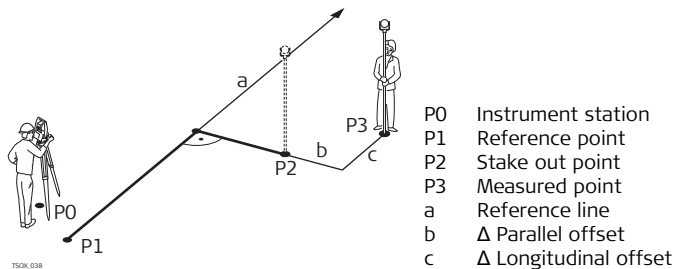

Access

Press **STAKE** from the **REFERENCE LINE - MAIN** screen.

Orthogonal stakeout

Enter the stake out elements for the target points to be staked out relative to the reference line.







Field	Description
Line	Longitudinal offset: Positive if stake out point is further away from the reference line.
Offset	Perpendicular offset: Positive if stake out point is to the right of the reference line.
Height	Height offset: Positive if stake out point is higher than the reference line.

Next step

Press **OK** to proceed to measurement mode.

**ORTHO.
STAKEOUT**

The signs for the distance and angle differences are correction values (required minus actual). The arrows indicate the direction to move to get to the stake out point.

ORTHO. STAKEOUT 1/2		
PtID	: P414	
hr	: 1.500 m	
Δ Hz	: ← -0.6764 g	P
Δ 	: ↓ -2.371 m	
Δ 	: ↑ 0.082 m	
ALL	DIST	REC
		↓

NextPt

To add the next point to be staked out.

Field	Description
ΔHz	Horizontal direction from the measured point to the stake out point. Positive if the telescope must be turned clockwise to the stake out point.
$\Delta \nearrow$	Horizontal distance from the measured point to the stake out point. Positive if the stake out point is further away than the measured point.
$\Delta \nearrow $	Height difference from the measured point to the stake out point. Positive if the stake out point is higher than the measured point.
$\Delta Offset$	Perpendicular distance from the measured point to the stake out point. Positive if the stake out point is to the right of the measured point.
$\Delta Line$	Longitudinal distance from the measured point to the stake out point. Positive if the stake out point is further away than the measured point.

Next step

- Either, press **ALL** to measure and record.
- Or, press **↓ PREV** to return to the **REFERENCE LINE - MAIN** screen.

9.5.6

Subapplication Grid Stakeout

Description

The Grid subapplication calculates and displays the stake out elements for the points on the grid, orthogonal ($\Delta Line$, $\Delta Offset$, $\Delta \nearrow |$) and polar (ΔHz , $\Delta \nearrow$, $\Delta \nearrow |$). The grid is defined without boundaries. It can be extended over the first and second base points of the reference line.

Example Grid Stakeout

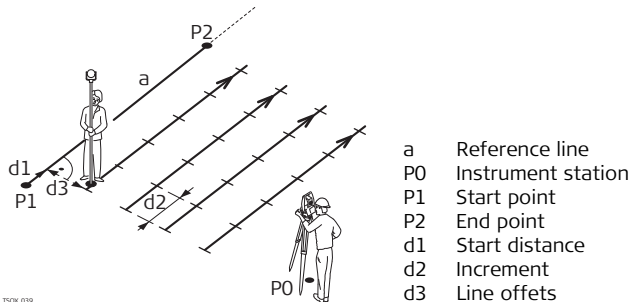

TSOK_039

Access

Press **GRID** from the **REFERENCE LINE - MAIN** screen.

GRID DEFINITION

Enter the chainage and the increment of grid points in length and cross direction of the reference line.

GRID DEFINITION	
Enter start chainage of grid!	
Start Chain:	2.000 m
Increment grid points by	
Increment :	3.500 m
Offset :	0.500 m
PREV	OK







Field	Description
Start Chain	Distance from the reference line start point to the beginning grid start point.
Increment	Length of incrementation.
Offset	Offset distance from the reference line.

Next step

Press **OK** to proceed to the **STAKEOUT GRID** screen.

STAKEOUT GRID

The signs for the distance and angle differences are correction values (required minus actual). The arrows indicate the direction to move to get to the stake out point.

STAKEOUT GRID 1/2		
PtID :	P415	
hr :	1.500 m	
Chainage :	2.000	
Offset<->:	0.000	
Δ Hz :	\rightarrow +0.4601 g	
Δ  :	\downarrow -2.464 m	
Δ  :	\uparrow 0.082 m	
ALL		DIST
REC		EDM

Field	Description
Line <->	Grid increment values. The stake out point is in the direction from the first to the second reference point.
Offset <->	Offset increment values. The stake out point is to the right of the reference line.
Δ Hz	Horizontal direction from the measured point to stake out point. Positive if the telescope must be turned clockwise to the stake out point.
Δ 	Horizontal distance from the measured point to stake out point. Positive if the stake out point is further away than the measured point.

Field	Description
$\Delta \blacktriangleleft$	Height difference from the measured point to the stake out point. Positive if the stake out point is higher than the measured point.
Δ Line	Longitudinal distance from the measured point to the stake out point. Positive if stake out point is further away than the measured point.
Δ Offset	Perpendicular distance from the measured point to the stake out point. Positive if stake out point is to the right of the measured point.

Next step

- Either, press **ALL** to measure and record.
- Or, press **ESC** to return to the **DEFINE GRID** screen and from there, press **PREV** to return to the **REFERENCE LINE - MAIN** screen.

9.5.7

Subapplication Line Segmentation

Description

The line segmentation subapplication calculates and displays the stake out elements for the points along the line, orthogonal (Δ Line, Δ Offset, $\Delta \blacktriangleleft$) and polar (Δ H_z, $\Delta \blacktriangleleft$, $\Delta \blacktriangleleft$). Line Segmentation is limited to the reference line, between the defined start and end points of the line.

Example Line Segmentation Stakeout

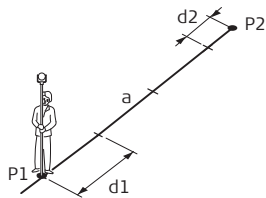

TS0X_040



- P0 Instrument station
- P1 First reference point
- P2 Second reference point
- a Reference line
- d1 Segment length
- d2 Misclosure

Access

Press **↓ SEGMENT** from the **REFERENCE LINE - MAIN** screen.

SEGMENT DEFINITION

Enter either the number of segments, or the length of segments and define how the remaining line length is treated. This misclosure can be placed at the start, at the end or distributed evenly along the line.

SEGMENT DEFINITION	
Line Length	: 35.497 m
Segment Length:	3.500 m
Segment No.	: 11
Misclosure	: 0.497 m
Distrib.	: At start ()
<div style="display: flex; justify-content: space-between; margin-top: 10px;"> PREV OK </div>	

Field	Description				
Line Length	Calculated length of the defined reference line.				
Segment Length	Length of each segment. Updated automatically if the number of segments is entered.				
Segment No.	Number of segments. Updated automatically if the segment length is entered.				
Misclosure	Any remaining line length after segment length has been entered.				
Distribution	Method of misclosure distribution. <table style="margin-left: 20px; border: none;"> <tr> <td style="padding-right: 10px;">None</td> <td>All of the misclosure will be placed after the last segment.</td> </tr> <tr> <td style="padding-right: 10px;">At start</td> <td>All of the misclosure will be placed before the first segment.</td> </tr> </table>	None	All of the misclosure will be placed after the last segment.	At start	All of the misclosure will be placed before the first segment.
None	All of the misclosure will be placed after the last segment.				
At start	All of the misclosure will be placed before the first segment.				







Field	Description
Equal	The misclosure will be equally distributed between all segments.

Next step



Press **OK** to proceed to the **STAKEOUT SEGMENT** screen.

STAKEOUT SEGMENT

The signs for the distance and angle differences are correction values (required minus actual). The arrows indicate the direction to move to get to the stake out point.

STAKEOUT SEGMENT 1/2		
PtID :	P415	
hr :	1.500 m	
Segment No:	1	
Cum. Length:	0.497	
Δ Hz :	← -2.1233 g	
Δ  :	↓ -1.450 m	
Δ  :	↑ 0.082 m	
ALL	DIST	REC EDM

Field	Description
Segment No	Segment number. Includes the misclosure segment, if applicable.
Cum.Length	Sum of the segment lengths. Changes with the current number of segments. Includes the misclosure segment length if applicable.

Field	Description
ΔHz	Horizontal direction from the measured point to the stake out point. Positive if the telescope must be turned clockwise to the stake out point.
Δ 	Horizontal distance from the measured point to the stake out point. Positive if the stake out point is further away than the measured point.
Δ 	Height difference from the measured point to the stake out point. Positive if the stake out point is higher than the measured point.
ΔLine	Longitudinal distance from the measured point to the stake out point. Positive if stake out point is further away than the measured point.
ΔOffset	Perpendicular distance from the measured point to the stake out point. Positive if stake out point is to the right of the measured point.

Messages

The following are important messages or warnings that may appear.

Messages	Description
Base line too short !	Base line is shorter than 1 cm. Choose base points such that the horizontal separation of both points is at least 1 cm.

Messages	Description
Coordinates invalid !	No coordinates or invalid coordinates for a point. Ensure that points used have at least Easting and Northing coordinates.
Save via RS232 !	Data Output: is set to Interf. in the SETTINGS menu. To be able to successfully start reference line, Data Output: must be set to Int.Mem.

Next step

- Either, press **ALL** to measure and record.
- Or, press **ESC** to return to the **DEFINE SEGMENT** screen and from there, press **PREV** to return to the **REFERENCE LINE - MAIN** screen.
- Or, continue selecting **ESC** to exit the application.

9.6**Reference Element - Reference Arc****9.6.1****Overview****Availability****TS02** Optional**TS06** ✓**TS09** ✓**Description**

Reference element is an overarching name for the two reference applications, Reference Line and Reference Arc.

The Reference Arc application allows the user to define a reference arc and then complete the following tasks with respect to the arc:

- Line & offset
- Stakeout (Point, Arc, Chord, Angle)

Access

1. Select **Prog** from the **MAIN MENU**.
2. Select **Reference Element** from the **PROGRAMS** menu.
3. Complete application pre-settings. Refer to "8 Applications - Getting Started".
4. Select **RefArc**.

Next step

Define the reference arc.

9.6.2

Defining the Reference Arc

Description

The reference arc can be defined by a center point and start point, or a start point, end point, and radius. All points can be either measured, manually entered, or selected from the memory.

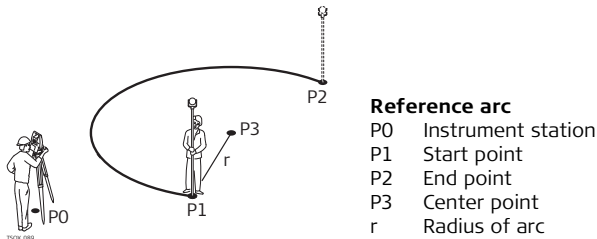



All arcs are defined in a clockwise direction and all calculations are made in two dimensions.

Access

Select **RefArc** and then the method to define the arc by:

- **Centre, Start Point.**
- **Start and End Pt, Radius.**

Reference Arc - Measure to start point

Field	Description
StartPt	Point ID of the start point.
CtrPt	Point ID of the center point.
EndPt	Point ID of the end point.
Radius	Radius of the arc.

Next step

After defining the reference arc the **REFERENCE ARC - MAIN PAGE** screen will appear.

REFERENCE ARC - MAIN PAGE

REFERENCE ARC - MAIN PAGE	
CtrPt :	-----
StartPt:	P410
EndPt :	P411
Radius :	32.000 m
NewArc	
MEASURE	
STAKE	

NewArc

To define a new base arc.

MEASURE

To measure Line & Offset.

STAKE

To stake out.

Next step

Select a softkey option, **MEASURE** or **STAKE**, to proceed a subapplication.

9.6.3

Subapplication Measure Line & Offset

Description

The Measure Line & Offset subapplication calculates from measurements or coordinates, longitudinal and orthogonal offsets and height differences of the target point relative to the reference arc.

Example reference arc - measure line & offset

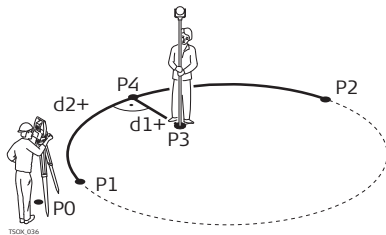

- P0 Instrument station
 P1 Start point
 P2 End point
 P3 Measured point
 P4 Reference point
 d1- Δ Offset
 d2+ Δ Line

Access

Press **MEASURE** from the **REFERENCE ARC - MAIN PAGE** screen.

Measure Line & Offset

Field	Description
Δ Line	Calculated distance longitudinal to the reference arc.
Δ Offset	Calculated distance perpendicular from the reference arc.
Δ 	Calculated height difference relative to the start point of reference arc.

Next step

- Either, press **ALL** to measure and record.
- Or, press **↓ PREV** to return to the **REFERENCE ARC - MAIN PAGE** screen.

9.6.4

Subapplication Stakeout

Description

The stakeout subapplication calculates the difference between a measured point and the calculated point. The reference arc application supports four ways to stake out:

- Stake out point
- Stake out chord
- Stake out arc
- Stake out angle

Stake out point

To stake out a point by entering a line and an offset value.

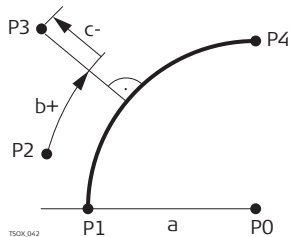

TSOX_042

- P0 Center point of arc
- P1 Start point of arc
- P2 Measured point
- P3 Stake out point
- P4 End point of arc
- a Radius of arc
- b+ Line offset
- c- Perpendicular offset

Stake out arc

To stake out a series of equidistant points along the arc.

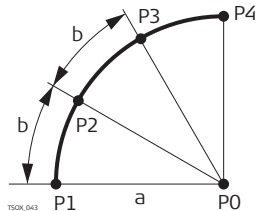

TSOX_043

- P0 Center point of arc
- P1 Start point of arc
- P2 Stake out point
- P3 Stake out point
- P4 End point of arc
- a Radius of arc
- b Arc length

Stake out chord

To stake out a series of equidistant chords along the arc.

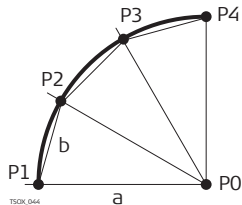

TSOX_044

- P0 Center point of arc
- P1 Start point of arc
- P2 Stake out point
- P3 Stake out point
- P4 End point of arc
- a Radius of arc
- b Chord length

Stake out angle

To stake out a series of points along the arc defined by the angle segments from the center point of the arc.

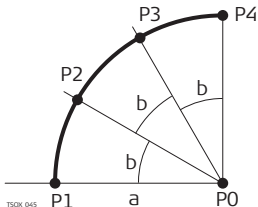

- P0 Center point of arc
- P1 Start point of arc
- P2 Stake out point
- P3 Stake out point
- P4 End point of arc
- a Radius of arc
- b Angle

Access

1. Press **STAKE** from the **REFERENCE ARC - MAIN PAGE** screen.
2. Select one of the four methods of stake out available.

Stake out point, arc, chord or angle

Enter the stake out values. Press **PT -/PT +** to toggle through the calculated stake out points.

Field	Description
Distrb.	For stakeout arc: Method of misclosure distribution. If the entered arc length is not an integer of the whole arc, there will be a misclosure.
None	All of the misclosure will be added to the last arc-section.
Equal	The misclosure will be equally distributed between all sections.







Field	Description
	Start Arc All of the misclosure will be added to the first arc-section.
Arc Length	For stakeout arc: The length of the arc-segment to stake out.
Chord Length	For stakeout chord: The length of the chord to stake out.
Angle	For stake out angle: The angle around the center point of the arc, of the points to be staked out.
Line	For stake out arc, chord and angle: Longitudinal offset from the reference arc. This is calculated by the arc length, chord length or angle and the selected misclosure distribution. For stake out point: Longitudinal offset from the reference arc.
Offset	Perpendicular offset from the reference arc.

Next step

Press **OK** to proceed to measurement mode.



**REF. ARC
STAKEOUT**

The signs for the distance and angle differences are correction values (required minus actual). The arrows indicate the direction to move to get to the stake out point.

REF. ARC STAKEOUT		
PtID:	P412	
hr :	1.500 m	
Δ Hz:	→ +0.9852 g	P
Δ 	↓ -0.514 m	
Δ 	↑ 0.082 m	
DIST		
REC		
NextPt		
		↓

NextPt

To add the next point to be staked out.

Field	Description
Δ Hz	Horizontal direction from the measured point to the stake out point. Positive if the telescope must be turned clockwise to the stake out point.
Δ 	Horizontal distance from the measured point to the stake out point. Positive if the stake out point is further away than the measured point.
Δ 	Height difference from the measured point to the stake out point. Positive if the stake out point is higher than the measured point.

Next step

- Either, press **↓ ALL** to measure and record.
- Or, press **↓ PREV** to return to the **REFERENCE ARC - MAIN PAGE** screen.
- Or, continue selecting **ESC** to exit the application.

9.7 Tie Distance

Availability

TS02 ✓

TS06 ✓

TS09 ✓

Description

Tie Distance is an application used to compute slope distance, horizontal distance, height difference and azimuth of two target points which are either measured, selected from the memory, or entered using the keypad.

Tie distance methods

The user can choose between two different methods:

- Polygonal: P1-P2, P2-P3, P3-P4.
- Radial: P1-P2, P1-P3, P1-P4.

Polygonal method

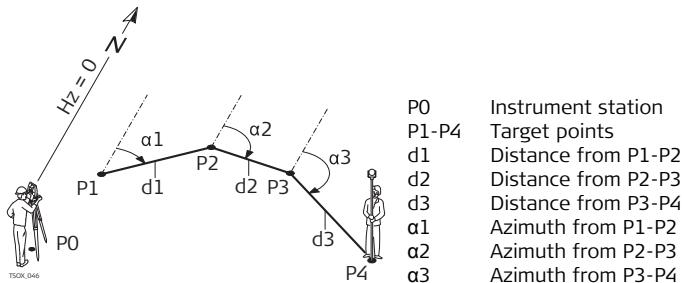

Radial method

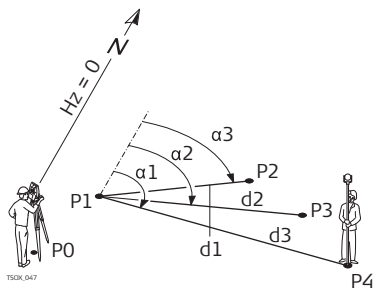

P0	Instrument station
P1-P4	Target points
d1	Distance from P1-P2
d2	Distance from P1-P3
d3	Distance from P1-P4
$\alpha 1$	Azimuth from P1-P4
$\alpha 2$	Azimuth from P1-P3
$\alpha 3$	Azimuth from P1-P2



Access

1. Select **Prog** from the **MAIN MENU**.
2. Select **Tie Distance** from the **PROGRAMS** menu.
3. Complete application pre-settings. Refer to "8 Applications - Getting Started".
4. Select **Polygonal** or **Radial**.

Tie distance measurements

After completing the measurements required, the **TIE DISTANCE RESULT** screen will appear.

**TIE DISTANCE
RESULT - Polygonal
method**

TIE DISTANCE RESULT	
Point 1:	P415
Point 2:	P416
Grade :	+2.9%
Δ  :	3.534 m
Δ  :	3.533 m
Δ  :	0.104 m
Bearing:	136.9971 g
NewPt 1	NewPt 2
	RADIAL

NewPt 1



To calculate an additional line. Application starts again at point 1.

NewPt 2

To set point 2 as the starting point of a new line. A new point 2 must be measured.

RADIAL

To switch to radial method.

Field	Description
Grade	Grade [%] between point 1 and point 2.
Δ 	Slope distance between point 1 and point 2.
Δ 	Horizontal distance between point 1 and point 2.
Δ 	Height difference between point 1 and point 2.
Bearing	Azimuth between point 1 and point 2.

Next step

Press **ESC** to exit the application.

9.8

Area & Volume

Availability

TS02 ✓

TS06 ✓

TS09 ✓

Description

Area & Volume is an application used to compute online areas to a maximum of 50 points connected by straights. The target points have to be measured, selected from memory, or entered via the keypad in a clockwise direction. The calculated area is projected onto the horizontal plane (2D) or projected onto the sloped reference plane defined by three points (3D). Furthermore a volume with constant height can be calculated in relation to the area (2D/3D).

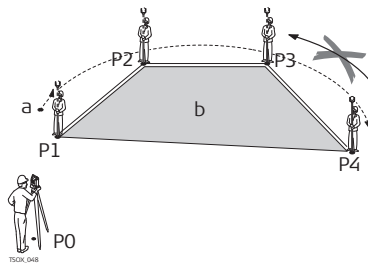

P0 Instrument station

P1 Start point

P2 Target point

P3 Target point

P4 Target point

a Perimeter, polygonal length from start point to the current measured point.

b Calculated area always closed to the start point P1, projected onto the horizontal plane.

Access

1. Select **Prog** from the **MAIN MENU**.
2. Select **Area & Volume** from the **PROGRAMS** menu.
3. Complete application pre-settings. Refer to "8 Applications - Getting Started".

Applications

FlexLine, 149

AREA & VOLUME

The graphic always shows the area projected onto the horizontal plane.

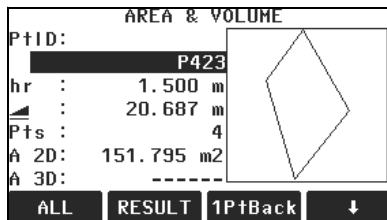
**1PtBACK**

To undo measurement or selection of the previous point.

RESULT

To display and record additional results (perimeter, volume).

↓ VOLUME

To calculate a volume with constant height. The heights have to be entered or measured.

↓ Def. 3D

To define the sloped reference plane by selecting or measuring three points.



The 2D area is calculated and displayed once three points have been measured or selected. The 3D area is calculated once the sloped reference plane is defined by three points.

Graphical representation

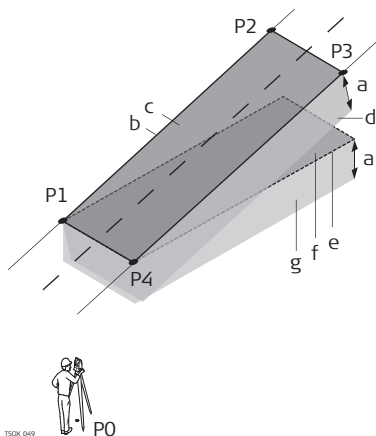

- P0 Instrument station
- P1 Target point which defines the sloped reference plane
- P2 Target point which defines the sloped reference plane
- P3 Target point which defines the sloped reference plane
- P4 Target point
- a Constant height
- b Perimeter (3D), polygonal length from the start point to the current measured point of the area (3D)
- c Area (3D), projected onto the sloped reference plane
- d Volume (3D) = $a \times c$
- e Perimeter (2D), polygonal length from the start point to the current measured point of the area (2D)
- f Area (2D), projected onto the horizontal plane
- g Volume (2D) = $f \times a$

Next step

Press **RESULT** to calculate area and volume and proceed to the **Area & Volume Result** screens.

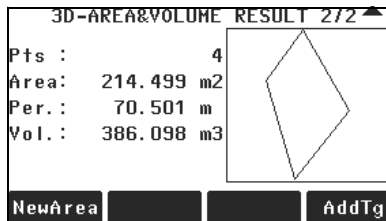
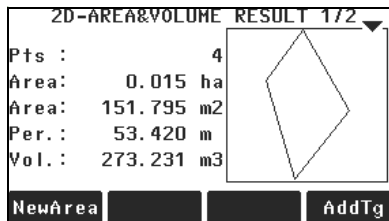
**2D/3D-AREA &
VOLUME RESULT****Next step**

Perimeter and volume are updated if further area points are added.

- Either, press **NewArea** to define a new area.
- Or, press **AddTg** to add a new target point to the existing area.
- Or, press **ESC** to exit the application.

9.9

Remote Height

Availability

TS02 ✓

TS06 ✓

TS09 ✓

Description

Remote Height is an application used to compute points directly above the base prism without a prism at the target point.

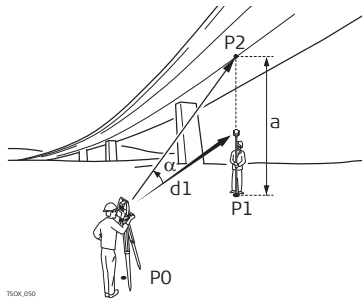

TS09_050

- P0 Instrument station
- P1 Base point
- P2 Remote point
- d1 Slope distance
- a Height difference from P1 to P2
- α Vertical angle between base point and remote point

Access

1. Select **Prog** from the **MAIN MENU**.
2. Select **Remote Height** from the **PROGRAMS** menu.
3. Complete application pre-settings. Refer to "8 Applications - Getting Started".

Remote height measurement

Measure to the base point or press **hr=?** to determine an unknown reflector height.

Next step

After measuring, the **REMOTE HEIGHT** screen appears.

REMOTE HEIGHT - Aim at remote point

Aim the instrument at the inaccessible remote point.

Field	Description
Δ 	Height difference between the base point and the remote point.
Height	Height of the remote point.

Next step

- Either, press **OK** to save the measurement and record the calculated coordinates of the remote point.
- Or, press **BASE** to enter and measure a new base point.
- Or, press **ESC** to exit the application.

9.10**Construction****9.10.1****Starting Construction****Availability****TS02** ✓**TS06** ✓**TS09** ✓**Description**

Construction is an application used to define a construction site by combining set-up of the instrument along a construction line, measuring and staking out points in relation to the line.

Access

1. Select **Prog** from the **MAIN MENU**.
2. Select **Construction** from the **PROGRAMS** menu.
3. Select **Set EDM**: to set the EDM settings. Refer to "4.2 EDM Settings".
4. Select:
 - **New construction line** - To define a new construction site, or
 - **Continue previous site** - To continue with a previous construction site (skips set-up).



If coordinates were entered by **ENH** and measured to known points, a plausibility check displays the calculated line length, the actual length and the difference.

Next step

Measure to the line start and end points and the **LAY-OUT** screen appears.

9.10.2

Layout

Description

Search or enter points for staking out relative to the defined construction line. The on-screen graphics show the position of the prism relative to the stake out point. Below the graphic, the exact values are displayed, combined with arrows to show the direction for staking out the point.



- Be aware that the line start point and the line end point are measured in the previous coordinate system. When staking out these points they appear in the old system and appear as shifted.

- During use of the application the previous orientation and station parameters will be replaced by the new calculated ones. The line start point will be set to E=0, N=0.
- The height of the line start point is always used as the reference height!

Access

- Either, select **New construction line** from the Construction pre-settings screen and measure start and end points of the line.
- Or, select **Continue previous site** from the Construction pre-settings screen.

LAY-OUT

The graphics are scaled to give a better overview. Therefore it is possible that the stake out point moves in the graphic.

LAY-OUT			
PtID:	P404		x
hr :	1.500 m		⊗
ΔLi:	-1.280 m	↑	0.181 m
ΔOf:	31.317 m	←	0.074 m
Δ \nearrow l:	-6.491 m	↑	0.099 m
DIST		REC	AsBUILT
			↓

AsBUILT

To switch to AsBuilt mode to check points relative to the construction line.

↓ ShiftLN

To enter values for shifting the line.

Field	Description
ΔLi	Longitudinal offset: Positive if target point is further away than the measured point.

Field	Description
Δ Of	Perpendicular offset: Positive if target point is to the right of the measured point.
Δ 	Height offset: Positive if target point is higher than the measured point.

Next step

- Either, press **AsBUILT** to check point locations relative to a construction line.
- Or, press **↓ ShiftLN** to enter offset values for shifting the construction line.

9.10.3

As Built Check

Description

The As built screen displays the Line, Offset and Δ  of a measured point in relation to the construction line. The on-screen graphics show the position of the measured point relative to the construction line.



The height of the line start point is always used as the reference height!

Access

Press **AsBUILT** from the **LAY OUT** screen.

AS-BUILT CHECK

The graphics are scaled to give a better overview. Therefore it is possible that the station point moves in the graphics.

AS-BUILT CHECK	
PtID:	P426
hr :	1.500 m
ΔLi :	-1.737 m
ΔOf :	0.912 m
$\Delta \nearrow$:	0.979 m
<div style="display: flex; justify-content: space-between; border-top: 1px solid black; border-bottom: 1px solid black;"> DIST REC EDM ← </div>	

LAYOUT

To switch to Layout mode to stake out points.

↓ ShiftLN

To enter values for shifting the line.

Field	Description
ΔLi	Longitudinal offset: Positive if measured point is further along the construction line from the start point.
ΔOf	Perpendicular offset: Positive if measured point is to the right of the construction line.
$\Delta \nearrow$	Calculated difference in height: Positive if measured point is higher than the construction line start point height.

9.11

9.11.1

COGO

Starting COGO

Availability

TS02 Optional

TS06 ✓

TS09 ✓

Description

COGO is an application used to perform **coordinate geometry** calculations such as, coordinates of points, bearings between points and distances between points
The COGO calculation methods are:

- Inverse and Traverse
- Intersections
- Offset
- Extension

Access

1. Select **Prog** from the **MAIN MENU**.
2. Select **COGO** from the **PROGRAMS** menu.
3. Complete application pre-settings. Refer to "8 Applications - Getting Started".
4. Select from the **COGO MAIN MENU**:
 - **Inverse & Traverse**
 - **Intersection**
 - **Offset**
 - **Extension**

9.11.2

Inverse and Traverse

Access

1. Select **Inverse & Traverse** from the **COGO MAIN MENU**.
2. Select **Inverse** or **Traverse**.

Inverse

Use the inverse subapplication to calculate the distance, direction, height difference and grade between two known points.

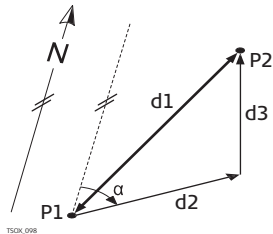
**Known**

- P1 First known point
- P2 Second known point

Unknown

- α Direction from P1 to P2
- d_1 Slope distance between P1 and P2
- d_2 Horizontal distance between P1 and P2
- d_3 Height difference between P1 and P2

Traverse

Use the traverse subapplication to calculate the position of a new point using the bearing and the distance from a known point. Offset optional.

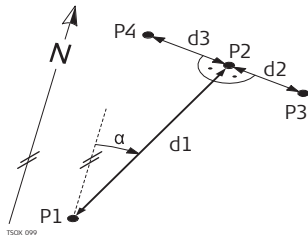
**Known**

- P1 Known point
- α Direction from P1 to P2
- d_1 Distance between P1 and P2
- d_2 Positive offset to the right
- d_3 Negative offset to the left

Unknown

- P2 COGO point without offset
- P3 COGO point with positive offset
- P4 COGO point with negative offset

9.11.3

Intersections

Access

1. Select **Intersection** from the **COGO MAIN MENU**.
2. Select the desired COGO method:
 - **Brg-Brg**
 - **Brg-Dst**
 - **Dst-Dst**
 - **Ln-Ln**

Bearing-Bearing

Use the bearing-bearing subapplication to calculate the intersection point of two lines. A line is defined by a point and a direction.

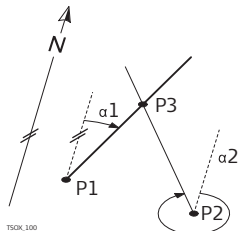

Known

- P1 First known point
- P2 Second known point
- $\alpha 1$ Direction from P1 to P3
- $\alpha 2$ Direction from P2 to P3

Unknown

- P3 COGO point

Bearing-Distance

Use the bearing-distance subapplication to calculate the intersection point of a line and a circle. The line is defined by a point and a direction. The circle is defined by the center point and the radius.

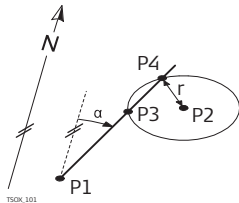
**Known**

- P1 First known point
- P2 Second known point
- α Direction from P1 to P3 and P4
- r Radius, as the distance from P2 to P4 or P3

Unknown

- P3 First COGO point
- P4 Second COGO point

Distance-Distance

Use the distance-distance subapplication to calculate the intersection point of two circles. The circles are defined by the known point as the center point and the distance from the known point to the COGO point as the radius.

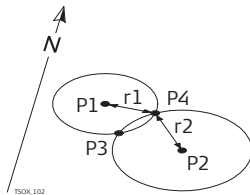
**Known**

- P1 First known point
- P2 Second known point
- $r1$ Radius, as the distance from P1 to P3 or P4
- $r2$ Radius, as the distance from P2 to P3 or P4

Unknown

- P3 First COGO point
- P4 Second COGO point

By Points

Use the line-line subapplication to calculate the intersection point of two lines. A line is defined by two points.

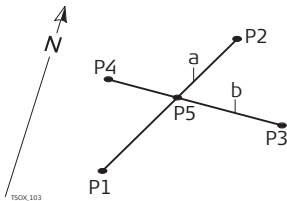

Known

- P1 First known point
- P2 Second known point
- P3 Third known point
- P4 Fourth known point
- a Line from P1 to P2
- b Line from P3 to P4

Unknown

- P5 COGO point

9.11.4

Offsets

Access

1. Select **Offset** from the **COGO MAIN MENU**.
2. Select the desired COGO method:

- **DistOff**
- **Set Pt**
- **Plane**

Distance - Offset

Use the distance-offset subapplication to calculate the distance and offset of a known point, with the basepoint in relation to a line.

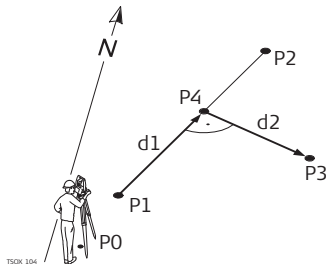
**Known**

- P0 Instrument station
- P1 Start point
- P2 End point
- P3 Offset point

Unknown

- d1 Δ Line
- d2 Δ Offset
- P4 COGO (base) point

Set point by....

Use the set point subapplication to calculate the coordinates of a new point in relation to a line from known longitudinal and offset distances.

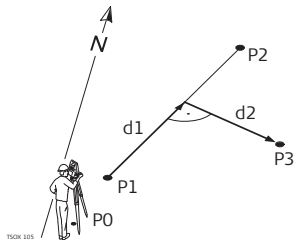
**Known**

- P0 Instrument station
- P1 Start point
- P2 End point
- d1 Δ Line
- d2 Δ Offset

Unknown

- P3 COGO point

Plane offset

Use the plane offset subapplication to calculate the coordinates of a new point and its height and offset, in relation to a known plane and offset point.

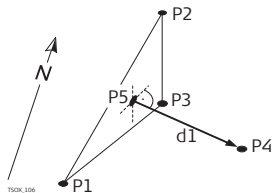

Known

- P1 Point 1 which defines plane
- P2 Point 2 which defines plane
- P3 Point 3 which defines plane
- P4 Offset point

Unknown

- P5 COGO (intersection) point
- d1 Offset

9.11.5

Extension

Access

Select **Extension** from the **COGO MAIN MENU**.

Extension

Use the Extension subapplication to calculate the extended point from a known base line.

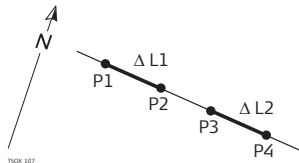

Known

- P1 Baseline start point
- P3 Baseline end point
- $\Delta L1, \Delta L2$ Distance

Unknown

- P2, P4 Extended COGO points

9.12

Road 2D

Availability

TS02 Optional**TS06** ✓**TS09** ✓

Description

Road 2D is an application used to measure or stake out points relative to a defined element. The element can be a line, curve or spiral. Chainage, incremental stake outs and offsets (left and right) are supported.

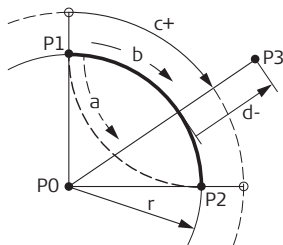

TS06.132

P0	Center point
P1	Start point of arc
P2	End point of arc
P3	Point to stake
a	Anti-clockwise
b	Clockwise
c+	Distance from start of arc, following curve
d-	Perpendicular offset from arc
r	Radius of arc

Access

1. Select **Prog** from the **MAIN MENU**.
2. Select **ROAD 2D** from the **PROGRAMS** menu.
3. Complete application pre-settings. Refer to "8 Applications - Getting Started".
4. Select the element type:
 - **Line**
 - **Curve**
 - **Spiral**

Elements

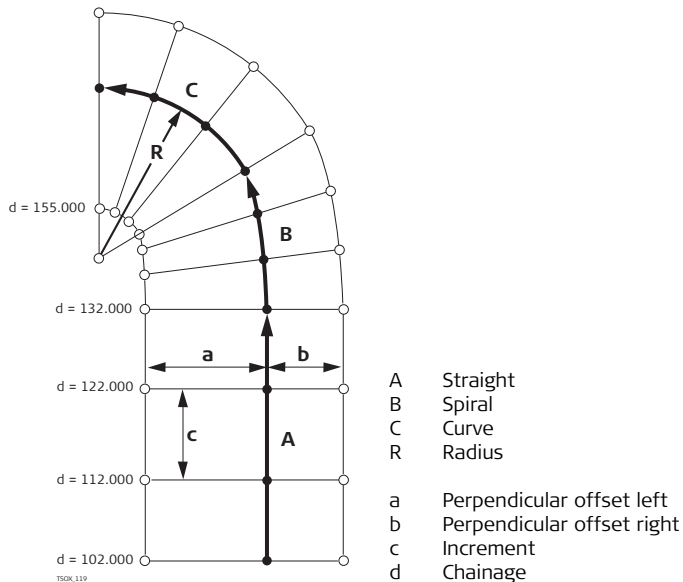

**Define the element
step-by-step**

1. Enter, measure or select from memory the start and end points.
2. For curve and spiral elements the **ROAD 2D** screen for defining the element appears.

ROAD 2D	
Select method and enter data!	
Method :	Rad/Par. ()
Radius :	400.000 m
Parameter:	600.000 m
Length :	900.000 m
Direction:	Clk-wise ()
Type :	Spir. In ()
PREV	OK

3. For a curve element:
 - Enter the radius and curve direction.
 - Press **OK**.
- For a spiral element:
 - Select the method to be used, **Rad/Par** or **Rad/Len**.
 - Enter the radius and parameter, or radius and length, depending on the method chosen.
 - Select the type and direction of the spiral.
 - Press **OK**.

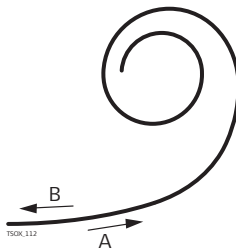

Spiral type

- A Spiral in
- B Sprial out

4. When the element has been defined the **ROAD 2D - MAIN PAGE** appears.

Chainage and method

Enter the chainage values and press:

- **STAKE:** to select the point and offset (center, left or right), to stake out and start the measurement. The correction from actual point to stake out point is shown on the display.
 - **MEASURE:** to measure, or select points from memory, to calculate the chainage, line and offset from the defined element.
-

Enter stakeout values

Enter stakeout values!		
Chainage	1100.000 m	
Offs. Left :	5.000 m	
Offs. Right:	4.000 m	
Increment :	10.000 m	
Height :	0.000 m	
PREV	RESET	OK

Next step

- If in stakeout mode, press **OK** to begin staking out.
- Or, if in measurement mode, press **ALL** to measure and record.

9.13

9.13.1

Roadworks 3D

Starting Roadworks 3D

Availability

TS02 -

TS06 Optional

TS09 ✓

Description

Roadworks 3D is an application used to stake out points or for as-built checks relative to a road alignment, including slopes. It supports the following features:

- Horizontal alignments with the elements straight, curve, and spiral (entry and exit as well as partial).
- Vertical alignments with the elements straight, curve and quadratic parabola.
- Upload of horizontal and vertical alignments which are in gsi data format of FlexOffice Road Line Editor.
- Creation, view and deletion of alignments onboard.
- Use of design height of vertical alignments or manually entered heights.
- Log file via Format manager of FlexOffice.

Roadworks 3D methods

Roadworks 3D has the following subapplications:

- Subapplication Check
- Subapplication Check Slope
- Subapplication Stake
- Subapplication Stake Slope



The application can be trialled 15 times. After 15 trials, it is necessary to enter the licence code.

**Roadworks 3D
step-by-step**

1. Create or upload road alignments.
 2. Select horizontal and/or vertical alignment files.
 3. Define stake/check/slope parameter.
 4. Select one of the Roadworks 3D subapplications
-



- The alignment file data has to be in the same data structure as FlexOffice Road Line Editor. These gsi files have unique identifiers for each element which are used by the application.
 - The alignments must be continuous because geometrical gaps and chainage equations are not supported.
 - The file name for the horizontal alignment file must have the prefix ALN, for example, ALN_HZ_Axis_01.gsi. The file name for the vertical alignment files must have the prefix PRF, for example PRF_VT_Axis_01.gsi. File names can be 16 characters long.
 - The uploaded or created road alignments are permanent and stored even if the application is closed.
 - Road alignments can be deleted onboard or via FlexOffice Data Exchange Manager.
 - Road alignments cannot be edited onboard. This needs to be done via FlexOffice Road Line Editor.
-

9.13.2

Basic Terms

Elements of a road project

Road projects consist, in general, of a horizontal and a vertical alignment.

Any project point P1 has E, N and H coordinates in a determined coordinate system and has three positions.

- P1' Position on natural surface
- P1'' Position on vertical alignment
- P1''' Position on horizontal alignment

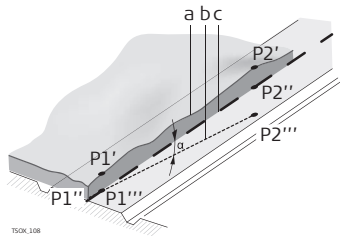

With a second point P2 the alignment is defined.

- P1' P2' Projection of the alignment onto the natural surface.
- P1'' P2'' Vertical alignment
- P1''' P2''' Horizontal alignment
- α Grade angle between the vertical and horizontal alignment.
- a Natural surface
- b Horizontal alignment
- c Vertical alignment

Horizontal geometry elements

For onboard input Roadworks 3D supports the following elements for horizontal alignments.

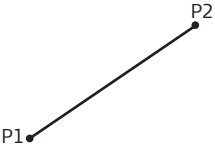
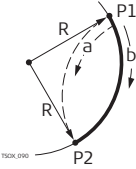
Element	Description
Straight	<p>A straight has to be defined by:</p> <ul style="list-style-type: none"> Start point (P1) and end point (P2) with known Easting and Northing coordinates.  <p>The diagram shows a solid line segment connecting point P1 at the bottom left to point P2 at the top right. The label 'TSOX_109' is located at the bottom left of the diagram.</p> <p>P1 Start point P2 End point</p>
Curve	<p>A circular curve has to be defined by:</p> <ul style="list-style-type: none"> Start point (P1) and end point (P2) with known Easting and Northing coordinates. Radius (R). Direction: Clockwise (b) or Anticlockwise (a).  <p>The diagram shows a circular arc connecting point P1 at the top right to point P2 at the bottom. Two radii, labeled 'R', are drawn from the center of the circle to P1 and P2. A dashed arrow labeled 'a' indicates an anticlockwise direction along the arc, and a solid arrow labeled 'b' indicates a clockwise direction. The label 'TSOX_090' is located at the bottom left of the diagram.</p> <p>P1 Start point P2 End point R Radius a Anticlockwise direction b Clockwise direction</p>

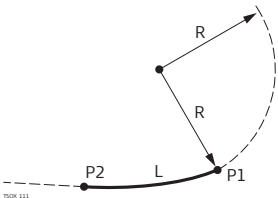
Element	Description
Spiral / Clothoid	<p>A spiral is a transition curve whose radius changes along its length. A spiral has to be defined by:</p> <ul style="list-style-type: none"> • Start point (P1) and end point (P2) with known Easting and Northing coordinates. • Radius at the start of the spiral (R). • Spiral parameter ($A = \sqrt{L \cdot R}$) or length (L) of the spiral. • Direction: Clockwise or Anticlockwise. • Spiral type: Spiral in or Spiral out.  <p> P1 Start point P2 End point R Radius L Length </p>

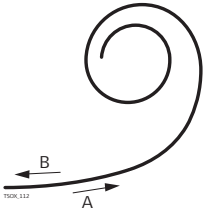
Element	Description
Spiral types	<ul style="list-style-type: none"> • Entry spiral (Spiral in = A): Spiral with a radius of infinity at the start and a given radius at the end. • Exit spiral (Spiral out = B): Spiral with a given radius at the start and radius of infinity at the end. • Partial/Ovoid spiral: A spiral with a given radius at the start and another given radius at the end.  <p style="text-align: right;"> A Entry spiral B Exit spiral </p>

Vertical geometry elements

For onboard input Roadworks 3D supports the following elements for vertical alignments.

Element	Description
Straight	A straight has to be defined by: <ul style="list-style-type: none"> • Start chainage and start height of P1. • End chainage and end height of P2, or length (L) and slope (%).

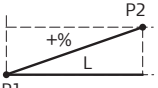
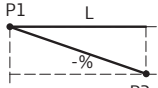
Element	Description		
			<p>P1 Start point P2 End point L Length % Slope</p>
Transition curve	<p>A circular curve has to be defined by:</p> <ul style="list-style-type: none"> • Start chainage and start height of P1. • End chainage and end height of P2. • Radius (R). • Type: Convex (crest) or Concave (sag). 		<p>a Convex b Concave</p> <p>P1 Start point P2 End point R Radius</p>

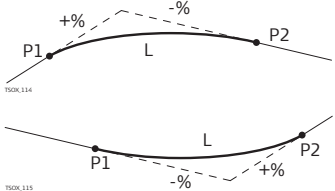
Element	Description
Quadratic parabola	<p>A quadratic parabola has the advantage that the rate of change of grade is constant, resulting in a "smoother" curve. A quadratic parabola has to be defined by:</p> <ul style="list-style-type: none"> • Start chainage and start height of P1. • End chainage and end height of P2. • Parameter, or Length (L), grade of entry straight (Grade In) and grade of exit straight (Grade Out).  <p>P1 Start point P2 End point L Length % Slope</p>

Horizontal and vertical geometry elements combined

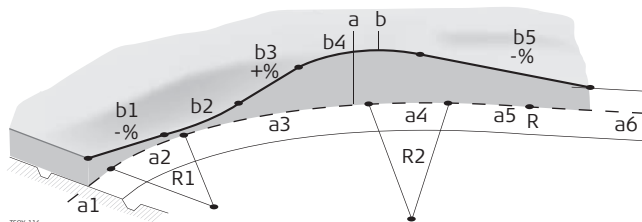

TSOX_116

a = Horizontal alignment (top view)

- R1 Radius 1
- R2 Radius 2
- a1 Straight
- a2 Curve with R1
- a3 Partial spiral with R1 and R2
- a4 Curve with R2
- a5 Spiral out with R2 and $R=\infty$
- a6 Straight

b = Vertical alignment (front view)

- b1 Straight
- b2 Curve
- b3 Straight
- b4 Parabola
- b5 Straight

- Tangent point



Start and end chainage and tangent points can be different for the horizontal and vertical alignments.

Slope elements

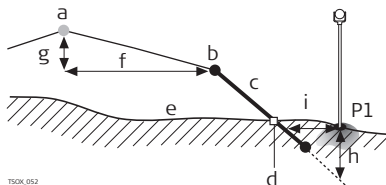

TSOK_052

- P1 Measured point
 a Horizontal alignment
 b Hinge point
 c Slope
 d Catch point
 e Natural surface
 f Defined offset
 g Defined height difference
 h Cut situation for defined slope
 i Δ Offset to catch point

Explanation of the slope elements:

- Horizontal alignment** at a defined chainage.
- Hinge point**, is defined by entered offset left/right and height difference.
- Slope** = ratio.
- Catch point**, or daylight point, indicates the point of intersection between the slope and the natural surface. Both the hinge point and the catch point lie on the slope.
- Natural surface**, is the undisturbed surface before project construction.

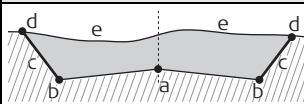
Cut / Fill	Description
Cut situation	 <p>a Horizontal alignment b Hinge point c Slope d Catch point e Natural surface</p>

TSOK_117

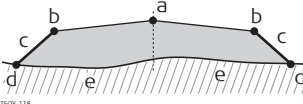
Cut / Fill	Description
Fill situation	 <p>a Horizontal alignment b Hinge point c Slope d Catch point e Natural surface</p>

9.13.3

Creating or Uploading Alignment Files

Description

Create horizontal and vertical road alignment files with FlexOffice Road Line Editor and upload them onto the instrument using the Data Exchange Manager. Alternatively, horizontal and vertical road alignments can be created onboard the instrument.

Access

1. Select **Prog** from the **MAIN MENU**.
2. Select **3D Roadworks** from the **PROGRAMS** menu.
3. Complete application pre-settings. Refer to "8 Applications - Getting Started".

Select alignment files

Field	Description
Horiz. Aln	List of available horizontal alignment files.  Using a horizontal alignment file is mandatory.
Verti. Aln	List of available vertical alignment files.

Field	Description
	 Using a vertical alignment file is not mandatory. A height can be defined manually instead.

Next step

- Either, press **New** to name and define a new alignment file.
- Or, press **OK** to select an existing alignment file and proceed to the **Define Stake/Check/Slope** values screen.

**Define Stake/
Check/Slope values**

Define Stake/Check/Slope values	
Offs. Left :	0.250 m
Offs. Right:	1.250 m
Ht. Diff. :	-1.000 m
Def. Chain :	10.000 m
Increment :	40.000 m
Height :	Use Design Hgt. (↕)
Manual Ht. :	...
<div style="display: flex; justify-content: space-around;"> STAKE CHECK STK_SLP ↓ </div>	

STAKETo start the subapplication **Stake**.**CHECK**To start the subapplication **Check**.**STK_SLP**To start the subapplication **Stake Slope**.**↓ CH_SLP**To start the subapplication **Check Slope**.

Field	Description
Offs. Left	Horizontal offset to the left of the horizontal alignment.
Offs. Right	Horizontal offset to the right of the horizontal alignment.
Ht. Diff.	Vertical offset, either up or down, from the horizontal alignment.

Field	Description
Def.Chain	Defined chainage for stake out.
Increment	Value by which the defined chainage can be incremented or decremented in subapplications Stake and Stake Slope.
Height	<p>Manual Height Height reference for height calculations. If enabled this height is used for all subapplications.</p> <p>Use Design Height The height reference for height calculations is the selected vertical alignment file.</p>
Manual Ht.	Height to be used for Manual Height .

Next step

Select a softkey option, **STAKE**, **CHECK**, **STK_SLP** or **↓ CH_SLP**, to proceed a subapplication.

9.13.4

Subapplication Stake

Description

The subapplication Stake is used to stake out points relative to an existing alignment. The height difference is relative to a vertical alignment or manually entered height.

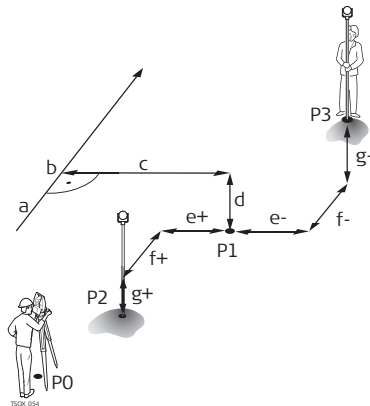









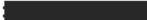



- P0 Instrument station
- P1 Target point
- P2 Measured point
- P3 Measured point
- a Horizontal alignment
- b Defined chainage
- c Offset
- d Height difference
- e+ Δ Offset, positive
- e- Δ Offset, negative
- f+ Δ Chainage, positive
- f- Δ Chainage, negative
- g+ Δ Height, positive
- g- Δ Height, negative

Access

Press **STAKE** from the **Define Stake/Check/Slope** values screen.

3D-ROAD STAKEOUT

3D-ROAD STAKEOUT 1/3		
PtID		P404 
hr	: 1.500 m	
Offset	: Center 	
Def. Chain	: 2.000 	
Δ Hz	:  -0.0029 g	
Δ 	:  -0.014 m	
Δ Height	:  -0.542 m 	
ALL		DIST
REC		EDM

Field	Description
Def.Chain	Selected chainage to stake out.
Δ Hz	Angle offset: Positive if the stake out point is to the right of the measured point.
Δ 	Horizontal offset: Positive if the stake out point is further away than the measured point.
Δ Height	Height offset: Positive if the stake out point is higher than the measured point.
Δ Chain	Longitudinal offset: Positive if the stake out point is further away than the measured point.
Δ Offset	Perpendicular offset: Positive if the stake out point is to the right of the measured point.

Field	Description
Def. East	Calculated East coordinate of the stake out point.
Def. North	Calculated North coordinate of the stake out point.
Def. Height	Calculated Height of the stake out point.

Next step

- Either, press ↓ **ALL** to measure and record.
 - Or, press **ESC** to return to the **Define Stake/Check/Slope** values screen.
-

9.13.5

Subapplication Check

Description

The subapplication Check is used for as-built checks. The points can be measured or selected from the memory. The chainage and offset values are relative to an existing horizontal alignment, and the height difference is relative to a vertical alignment or manually entered height.

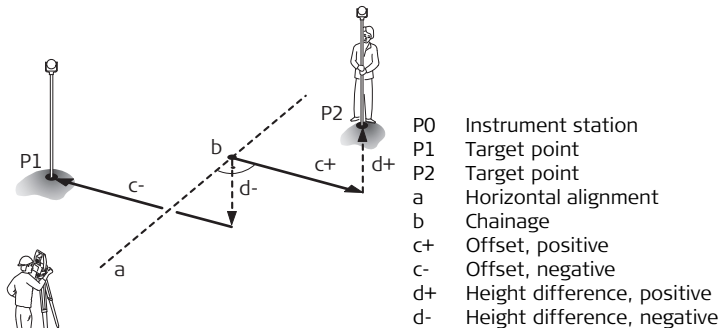





Defined chainage and Increment values will not be considered in the subapplication Check.

Access

Press **CHECK** from the **Define Stake/Check/Slope** values screen.

3D-ROAD CHECK

3D-ROAD CHECK 1/2		
PtID :	P403	
hr :	1.500 m	
Offset :	Center	
Chainage:	8.390 m	
Offset :	-0.000 m	
Ht. Diff.:	0.542 m	
ALL		↓
DIST		
REC		

Field	Description
Offset	Defined horizontal offset. Left, Right or Center.
Chainage	Current chainage from measured point.
Offset	Perpendicular offset to alignment.
Ht.Diff	Height difference between the measured point and the defined height.
ΔEast	Calculated difference in Easting coordinate between the measured point and the alignment element.
ΔNorth	Calculated difference in Northing coordinate between the measured point and the alignment element.

Next step

- Either, press **ALL** to measure and record.
- Or, press **ESC** to return to the **Define Stake/Check/Slope** values screen.

9.13.6

Subapplication Stake Slope

Description

The subapplication Stake Slope is used to stake out the catch point, which is the intersection point of a defined slope with the natural surface. The slope is always defined as starting from a hinge point. If the parameter offset right/left and height difference are not entered, the point at the defined chainage on the horizontal alignment is the hinge point.

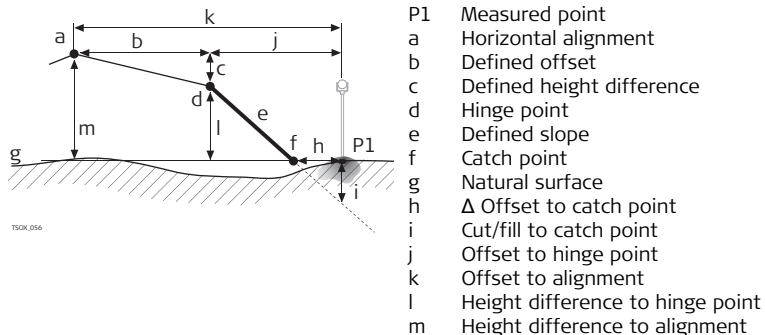

Access

Press **STK-SLP** from the **Define Stake/Check/Slope** values screen.

Define Slope for StakeOut

```

Define Slope for Stakeout!
Offset      :      Center  (left arrow) (right arrow)
Def.Chain   :      10.000  (left arrow) (right arrow)

SlopeType   :      Right down (left arrow) (right arrow)
SlopeGrade:  1.000:  2.000 h:v

PREV  RESET  OK

```

Field	Description
Offset	Horizontal offset from the horizontal alignment to define the hinge point.
Def.Chain	Defined chainage for stakeout.
SlopeType	Type of slope. Refer to "Slope Type".
SlopeGrade	Slope ratio. Refer to "Slope Grade".

Slope Type

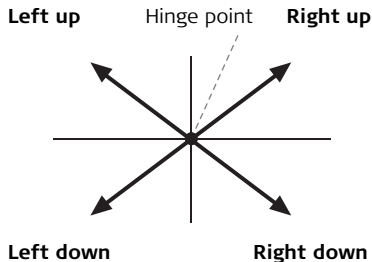

Left up

Creates an upward plane extending to the left of the defined hinge point.

Right up

Creates an upward plane extending to the right of the defined hinge point.

Left down

Creates a downward plane extending to the left of the defined hinge point.

Right down

Creates a downward plane extending to the right of the defined hinge point.





Slope Grade

Ratio of the slope. The unit for slope grade is defined in the **SETTINGS** screen. Refer to "4.1 General Settings".



Next step

Press **OK** to proceed to the **SLOPE STAKEOUT** screen.

SLOPE STAKEOUT

SLOPE STAKEOUT 173		
PfID :	P434	
hr :	1.500 m	
Def. Chain :	2.000	
ΔChain :	↓ -0.052 m	P
ΔOffset :	← 0.0880 m	
Cut :	0.0440 m	
Act. Slp :	1.000: 2.047 h:v	I
ALL	DIST	REC
		↓

Field	Description
Def.Chain	Defined chainage for stake out.
ΔChain	Difference between the defined chainage and the measured chainage.
ΔOffset	Horizontal offset between the catch point of defined slope and the measured position.
Cut/Fill	Vertical offset between the catch point of the defined slope and the measured position. A cut is above the slope, a fill is below the slope.
Act. Slp	Measured slope of the reflector position to the hinge point.
Offs. Hng	Measured offset to the horizontal alignment including offset right and offset left.

Field	Description
ΔH Hng	Height difference to the hinge point. The vertical offset between the defined height at the current chainage, and the measured position, including the defined height difference.
 Hng	Slope distance from the measured point to the hinge point.
Height	Height value of the measured point.
Act. Ch.	The measured chainage.
Offs. Aln	Measured offset to the horizontal alignment excluding offset right and offset left.
ΔH Aln	Height difference to the alignment. The vertical offset between defined height at the current chainage, and the measured position, excluding the defined height difference.
 Aln	Slope distance from the measured point to the alignment.

Sign convention

Cut situation

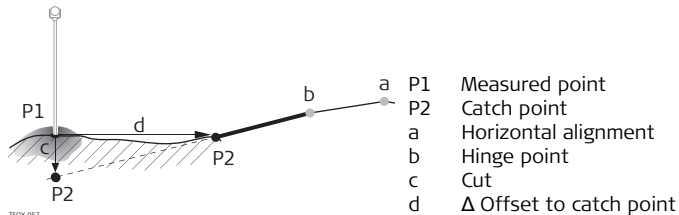

Fill situation

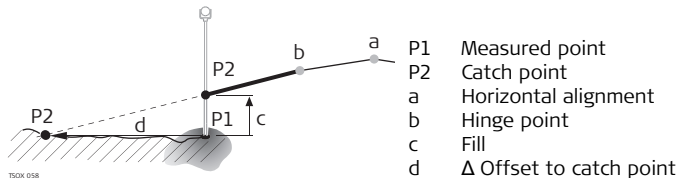

Next step

- Either, press **ALL** to measure and record.
- Or, press **ESC** to return to the **Define Stake/Check/Slope** values screen.

9.13.7

Subapplication Check Slope

Description

The subapplication Check Slope is used for as-built checks and to get information about slopes, for example on a natural surface. If the parameter offset left/right and height difference are not entered, the point on the horizontal alignment is the hinge point.

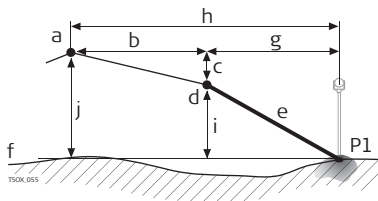

- P1 Measured point
- a Horizontal alignment
- b Defined offset
- c Defined height difference
- d Hinge point
- e Actual slope
- f Natural surface
- g Offset to hinge point
- h Offset to alignment
- i Height difference to hinge point
- j Height difference to alignment



Defined chainage and increment values will not be considered in the subapplication Check.

Access

Press **↓ CH-SLP** from the **Define Stake/Check/Slope** values screen.

Check slope values

SLP. CHK HINGE VAL. 1/3	
PtID :	P434
hr :	1.500 m
Offset :	Left
Chainage:	12.809 m
Offs. Hng:	0.250 m
Δ H Hng:	-0.832 m
Act. Slp:	1.000: 1.892 h:v
ALL	DIST
REC	↓

Field	Description
Offset	Defined horizontal offset. Left, Right or Center.
Chainage	Current chainage from measured point.
Offs. Hng	Offset to hinge. Measured offset to the horizontal alignment including offset right and offset left.
ΔH Hng	Height difference to the hinge point. The vertical offset between the defined height at the current chainage, and the measured position including defined height difference.
Act. Slp	The measured slope ratio of the measured point to the hinge point.
▲ Hng	Slope distance from the measured point to the hinge point.
Height	Height value of the measured point.

Field	Description
Offs. Aln	Measured offset to the horizontal alignment excluding offset right and offset left.
ΔH Aln	Height difference to the alignment. The vertical offset between defined height at the current chainage, and the measured position, excluding the defined height difference.
 Aln	Slope distance from the measured point to the alignment.

Next step

- Either, press **ALL** to measure and record.
- Or, press **ESC** to return to the **Define Stake/Check/Slope** values screen.
- Or, continue selecting **ESC** to exit the application.

9.14

TraversePRO

9.14.1

Overview

Availability

TS02 -

TS06 Optional

TS09 ✓



The application TraversePRO can be trialled 15 times. After 15 trials, it is necessary to enter a licence code.

Description

TraversePRO is an application used to establish control networks whereby other survey operations such as topographic surveys or point stake outs can be completed.

	<p>The TraversePRO methods include 2D helmert transformation, compass rule and transit rule.</p>
2D Helmert transformation	<p>A helmert transformation is calculated based on two control points. These must be the start point and the end, or closing, station. Shift, rotation and scale factor will be computed and applied to the traverse.</p> <p>Starting a traverse without an initial backsight measurement will automatically result in a helmert transformation, unless, the use of the start azimuth is confirmed after the the traverse closure. If this occurs then either of the other methods below could be used, or the traverse left open.</p>
Compass rule	<p>The coordinate misclosure will be distributed with respect to the length of the traverse legs. The compass rule assumes that the biggest error comes from the longest traverse observations. This method is suitable when the precision of the angles and distances are approximately equal.</p>
Transit rule	<p>The coordinate misclosure will be distributed with respect to the coordinate changes in Easting and Northing. Use this method if the angles were measured with a higher precision than the distances.</p>
TraversePRO step-by-step	<ol style="list-style-type: none">1. Start and configure TraversePRO.2. Enter station data.3. Select starting method.4. Measure a backsight point or go directly to step 5.5. Measure a foresight point.6. Repeat for the number of sets.7. Move to the next station.

TraversePRO options

- It is also possible to observe sideshots and check points during the traverse, however, check points are not included in the traverse adjustment.
- At the end of the traverse, results are displayed and an adjustment may be calculated if desired.

9.14.2

Starting and Configuring TraversePRO

Access

1. Select **Prog** from the **MAIN MENU**.
2. Select **Traverse** from the **PROGRAMS** menu.
3. Complete application pre-settings.
 - **Set Job:**

Only one traverse per job is allowed. If an adjusted or finished traverse is already part of the selected job, then select another job. Refer to "8 Applications - Getting Started".
 - **Set Tolerances:**

Use Tol.: YES to activate the use of tolerances.
Enter limits for horizontal direction (the difference between measured and calculated azimuth to the closing point), distance (the distance between known and measured closing point), and for differences in Easting, Northing and Height. If the adjustment results, or the deviation for a check point, exceed these limits a warning message appears.
Press **OK** to save the limits and return to the **Pre-settings** screen.
4. Select **Start** to begin the application.



It is not recommended to start a traverse if the memory is almost full. Doing so, may mean the traverse measurements and results cannot be saved. Accordingly, a message is displayed if less than 10% of the memory is free.

Traverse configuration

Field	Description
Traverse ID	Name of the new traverse.
Descr	Description, if desired.
Operator	Name of the user who will be using the new traverse, if desired.
Method	<p>B'F'F''B'' All points are measured in face I, then all points are measured in face II in reverse sequential order.</p> <p>B'B''F''F' The backsight point is measured in face I immediately followed by face II. Other points are measured in alternating face order.</p> <p>B'F' All points are measured in face I only.</p>
Nr. of Sets	Number of sets. Limited to 10.
Use Face-Tol	Important when measuring with face I and II. This checks if both measurements are within a defined limit. If the limit is exceeded, a warning message is displayed.
Face Tol.	The limit that will be used for checking the face tolerance.

Next step

Press **OK** to confirm the traverse configuration and proceed to the **MEASURE TRAVERSE** screen.

MEASURE TRAVERSE - Enter Station data

MEASURE TRAVERSE	
Enter Station data!	
Stat. ID	: S101
hi	: 1.400 m
Desc	: [REDACTED] -----
[FIND] [LIST] [OK] [↓]	

LEVEL

To access the electronic level / plummet screen

Field	Description
Stat. ID	Name of the station.
hi	Height of the instrument.
Descr.	Description of the station, if desired.



Every Traverse must start on a known point.

Next step

Press **OK** to confirm station data and proceed to the **TRAVERSE START** screen.

9.14.3

Measuring Traverse

Access

From the **TRAVERSE START** screen select one of the following:

1. **Without known Backsight:** Starts the traverse without a known backsight. The measurements begin to a foresight point.
 2. **With known Backsight:** Starts the traverse with a known backsight.
-

Without known backsight

Start a traverse without a known backsight

- Start on a known point without an initial measurement to a known backsight. Stop on a known point, or make a final foresight measurement to a known closing point.

If the coordinates of the start station are unknown, the Free Station application can be run before and by choosing **Start a traverse without a known backsight** the last known system azimuth from the Free Station application can be used.

If the start azimuth is unknown and a Helmert transformation will be performed at the end of the traverse, then also use **Start a traverse without a known backsight**.

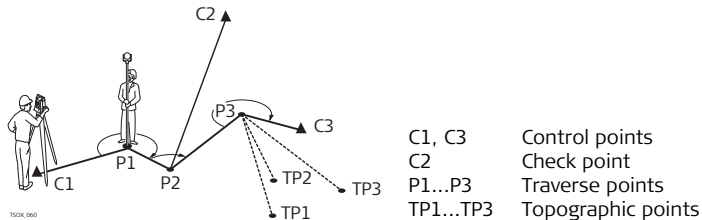

With known backsight

Start a traverse with a known backsight

- Start on a known point with an initial measurement to a known backsight.
- Stop on a known point and optionally measure to a known closing point.

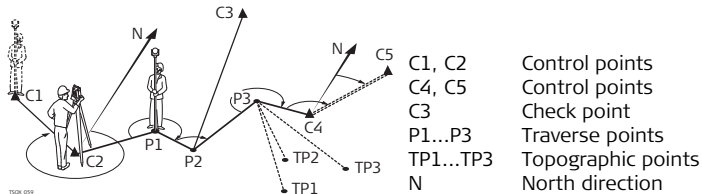

**Measure traverse -
Sight backsight**

Field	Description
BS ID	Point ID of the backsight point.
Desc.	Description of the backsight point.
Stat. ID	Name of the station.
Code	Point code, if desired.

Next step

Depending on the traverse method configured, after the measurement either the **Sight Backsight Point** screen stays active for measuring the backsight point in a second face, or the **Sight Foresight Point** screen appears for measuring the foresight point.

**Measure traverse -
Sight foresight****Next step**

Depending on the traverse method configured, after the measurement either the **Sight Foresight Point** screen stays active for measuring the foresight point in a second face, or the **Sight Backsight Point** screen appears for measuring the backsight point.

Interrupt a set

To interrupt a set, press **ESC** to exit the backsight or foresight screen. The CONTINUE WITH.... screen will appear.

CONTINUE WITH...

Field	Description
Redo last measurement	Returns to last measured point, can be either a backsight or a foresight point. The last measurement is not stored.

Field	Description
Redo whole station	Returns to first sight point screen. The data from the last station is not stored.
Exit traverse	Returns to the PROGRAMS menu. The traverse stays active and can be continued later. The data from the last station is lost.
PREV	Returns to the previous screen where ESC was pressed.

Repetitive loop for the number of sets

Alternating between screens for the backsight and foresight measurements continues according to the configured number of sets. The number of sets and the face are indicated in the top right corner of the screen. For example 1/I means set 1 in face I.

9.14.4

Moving ahead

Number of defined sets is achieved

When the number of defined sets is achieved, the **TRAVERSE MAIN** screen is displayed automatically. The accuracy of the set measurements is checked. The set can be accepted or redone.

Moving ahead with the Traverse

From the **TRAVERSE MAIN** screen, select an option to move ahead with the traverse, or press **ESC** to redo the last station.

Field	Description
Survey Sideshot	Enables the measurement of standard survey and topographic points. Measured points are stored with a TraversePRO flag. If the traverse is finally adjusted, these points will be updated. DONE To exit the Measure Sideshots screen and returns to the TRAVERSE MAIN screen.
Move to next Station	Move to the next station. The instrument can either be left on or turned off. If the instrument is turned off and then turned on again later, the message Last traverse not yet finished or processed - continue? will display. Selecting YES will re-open the Traverse to continue at the new station. The start screen for the next station is similar to the Enter Station Data screen. The point ID of the foresight point of the last station is suggested as station ID automatically. Run through the loop of backsight and foresight measurements until the number of sets is reached.

Field	Description
Measure Checkpoint	<p>By measuring a check point it is possible to check whether the Traverse is still within certain deviations. A check point is excluded from the traverse calculation and adjustment, however, all measurement data and results observed from a check point are stored.</p> <ol style="list-style-type: none"><li data-bbox="617 325 1336 381">1. Enter the name of the check point and the height of the reflector.<li data-bbox="617 391 1071 416">2. Press OK to go to the next screen.<li data-bbox="617 426 1284 482">3. Measure the check point. The differences in Easting, Northing and Height are displayed. <p>A message will appear if the tolerances defined in the TraversePRO configuration are exceeded.</p>

Next step

Close the traverse by selecting **CLOSE** in the **Sight Foresight** screen before measuring a foresight point after a backsight point measurement.

9.14.5

Closing a Traverse

Access

Press **CLOSE** in the **Sight Foresight** screen before measuring a foresight point after a backsight point measurement.

CLOSE TRAVERSE

CLOSE TRAVERSE...			
F1	At known Station to known Closing Point		
F2	To known Closing Point		
F3	At known Station only		
F4	Leave open		
F1	F2	F3	F4

F1 - F4 To select menu item.

Field	Description
At known Station to known Closing Point	<p>To close a traverse at a known station to a known closing point. Use when setup on the closing station, and the coordinates for the station and the closing point are known.</p> <p> If this method is chosen a distance measurement is mandatory.</p> <ol style="list-style-type: none"> 1. Input the data for both points. 2. Measure to the closing point. 3. The results are displayed.

Field	Description
To known Closing Point	To close a traverse to a known closing point. Use when setup on an unknown station and only the coordinates of the closing point are known. <ol style="list-style-type: none"> 1. Input the data for the point. 2. Measure to the closing point. 3. The results are displayed.
At known Station only	To close a traverse at a known station only. Use when setup on the closing station and the coordinates for it are known. <ol style="list-style-type: none"> 1. Input the data for the closing station. 2. The results are displayed.
Leave open	To leave the traverse open. There is no last traverse station. <ol style="list-style-type: none"> 1. The results are displayed.



If the traverse started without a known backsight point, and options **At known Station to known Closing Point** or **To known Closing Point** are selected, then, for calculating results, it is possible to use the system azimuth saved in the instrument from another application. For example, if Free Station was used before TraversePRO.

Next step

Select an option, from the **CLOSE TRAVERSE** menu to proceed to the **TRAVERSE RESULTS** screen.

TRAVERSE RESULTS

TRAVERSE RESULTS 1/2	
Traverse ID:	TRAV_2000
Start Stn. :	S101
End Stn. :	S101
No. of Stn. :	3
Total Dist.:	31.912 m
1D Accuracy:	1/17.8256
2D Accuracy:	1/2.9509
ADJUST ViewTol S-SHOT EndTrav	

ADJUST

To calculate an adjustment. Unavailable when the traverse is left open.

ViewTol

To view the tolerances for the traverse.

S-SHOT

To measure a sideshot.

EndTrav

To record the results and end the traverse.

Field	Description
Traverse ID	Name of the traverse.
Start Stn.	Point ID of the start station.
End Stn.	Point ID of the end station.
No. of Stn.	Number of stations in the traverse.
Total Dist.	Total distance of the traverse.
1D Accuracy	Accuracy in 1D. $1/\left(\frac{\text{Length of Traverse}}{\text{Height Misclosure}}\right)$
2D Accuracy	Accuracy in 2D. $1/\left(\frac{\text{Length of Traverse}}{\text{Linear Misclosure}}\right)$

Field	Description
L. of Error	Length/distance error.
Azimuth Err.	Azimuth closure error.
Δ East, Δ North, Δ Height	Calculated coordinates.

Next step

Press **ADJUST** from the **TRAVERSE RESULTS** screen to calculate the adjustments.

SET ADJUSTMENTS PARAMETERS

```

SET ADJUSTMENT PARAMETERS
No. of Stn. :                3
Azimuth Err:                ----, ---- g
Misc.-Distr: COMPASS (|)
Hgt. - Distr:                EQUAL (|)
Scale :                      *** **
Use Scale :                   NO (|)

```

OK

Field	Description
No. of Stn.	Number of stations in the traverse.
Azimuth Err	Azimuth closure error.
Misc.-Distr	For misclosure distribution.

Field	Description
	Angle misclosures are distributed equally. COMPASS For surveys where angles and distances were measured with equal precision. TRANSIT For surveys where angles were measured with a higher precision than the distances.
Hgt.-Distr	The height error can be distributed equally, by distance or not at all.
Scale	PPM value defined by the calculated distance between start and end point divided by the distance measured.
Use Scale	Whether to use the calculated ppm.



- Depending on the number of measured points the calculation may take some time. A message is displayed during the processing.
- Adjusted points are stored as fixpoints with an additional prefix, for example point BS-154.B is stored as CBS-154.B.
- After the adjustment the TraversePRO application is exited and the system returns to the **MAIN MENU**.

Messages

The following are important messages or warnings that may appear.

Messages	Description
Memory is almost full. Continue?	This message occurs if less than 10% of the memory is free. It is not recommended to start a traverse if the memory is almost full. Doing so, may mean that the traverse measurements and the results cannot be saved.
Current job contains an adjusted traverse. Select a different job.	Only one traverse per job is allowed. Another job must be selected.
Last traverse not yet finished or processed - continue?	The TraversePRO program was quit without closing a traverse. The traverse can be continued on a new station, left unfinished, or a new traverse started and the old traverse data overwritten.
Do you really want to start a new traverse? All existing traverse data will be overwritten.	Confirmation of this message will start a new traverse and the old traverse data will be overwritten.
REDO last station? Measurements on this station will be overwritten.	Confirming returns to the first sight point screen for the previous station measurements. The data from the last station is not stored.

Messages	Description
QUIT Traverse Application? Current Station data will be lost.	Quitting the application returns to the MAIN MENU . The traverse can be continued later, but the current station data will be lost.
Tolerances exceeded. Accept?	The tolerance limits have been exceeded. If not accepted, the calculations can be redone.
Traverse points are recalculated and newly stored.	An information message displayed while the adjustment is calculated.

Next step

- Either, after the adjustment the TraversePRO application is exited.
- Or, press **ESC** to exit the application.

9.15**Reference Plane****Availability****TS02** Optional**TS06** ✓**TS09** ✓**Description**

Reference Plane is an application used to measure points relative to a reference plane. It can be used for the following tasks:

- Measuring a point to calculate and store the perpendicular offset to the plane.
- Calculating the perpendicular distance from the intersection point to the local X- and Z-axis. The intersection point is the footprint point of the perpendicular vector from the measured point through the defined plane.

- Viewing, storing and staking out the coordinates of the intersection point.
- A reference plane is created by measuring three points on a plane. These three points define a local coordinate system:
- The first point is the origin of a local coordinate system.
 - The second point defines the direction of the local Z-axis.
 - The third point defines the plane.

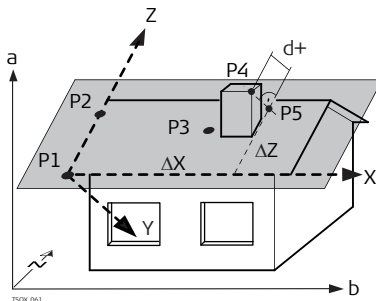

- X X-axis of local coordinate system.
- Y Y-axis of local coordinate system.
- Z Z-axis of local coordinate system.
- P1 First point, origin of local coordinate system.
- P2 Second point
- P3 Third point
- P4 Measured point. This point is probably not located on the plane.
- P5 Footprint point of the perpendicular vector from P4 to the defined plane. This point is definitely located on the defined plane.
- d+ Perpendicular distance from P4 to the plane.
- ΔX Perpendicular distance from P5 to the local X-axis.
- ΔZ Perpendicular distance from P5 to the local Z-axis.

The perpendicular distance to the plane can be positive or negative.

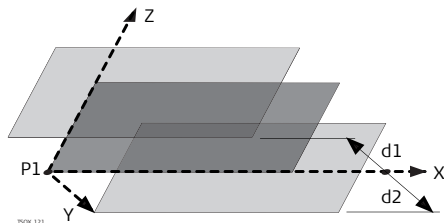

P1	Origin of plane
X	X-axis of plane
Y	Y-axis of plane
Z	Z-axis of plane
d1	Positive offset
d2	Negative offset

Access

1. Select **Prog** from the **MAIN MENU**.
2. Select **Ref Plane** from the **PROGRAMS** menu.
3. Complete application pre-settings. Refer to "8 Applications - Getting Started".

Measure plane and target points

1. Once the plane has been defined by three points, the **Measure Target point** screen appears.
2. Measure and record the target point. The results are displayed in the **REFERENCE PLANE RESULT** screen.

REFERENCE PLANE RESULT

REFERENCE PLANE RESULT	
Int. PtID:	P445
Offset :	-0.706 m
ΔX :	0.048 m
ΔZ :	9.793 m
East :	18.279 m
North :	18.082 m
Height :	6.632 m
NewTgt	STAKE
NewPlan	EXIT

NewTgt

To record and save the intersection point and to proceed to measure a new target point.

STAKE

To display stake out values for the intersection point.

NewPlan

To define a new reference plane.

Field	Description
Int. PtID	Point ID of the intersection point, the perpendicular projection of the target point on the plane.
Offset	Calculated perpendicular distance between target point and plane (intersection point).
ΔX	Perpendicular distance from the intersection point to the local Z-axis.
ΔZ	Perpendicular distance from the intersection point to the local X-axis.
East	Easting coordinate of the intersection point.
North	Northing coordinate of the intersection point.
Height	Height of the intersection point.

10 Data Management

10.1 File Management

Access

Select **Manage** from the **MAIN MENU**.

FILE MANAGEMENT

The File Management menu contains all functions for entering, editing, checking and deleting data in the field.

FILE MANAGEMENT 1/2		
F1	Job	(1)
F2	Fixpoints	(2)
F3	Measurements	(3)
F4	Codes	(4)
F1	F2	F3
F4		

F1-F4

To select menu item.

Menu item	Description
Job	To view, create and delete jobs. Jobs are a summary of data of different types, for example, fixed points, measurements or codes. The job definition consists of the job name and user. The system generates time and date at the time of creation.

Menu item	Description
Fixpoints	To view, create, edit and delete fixpoints. Valid fixed points contain at least the point ID and the coordinates E, N or H.
Measurements	To view and delete measurement data. Measurement data available in the internal memory can be searched for via a specific point search, or by viewing all points within a job.
Codes	To view, create, edit and delete codes. To each code a description and a maximum of 8 attributes with up to 16 characters each can be assigned.
Formats	To view and delete data format files.
Delete Job Memory	<p>To delete individual jobs, fixpoints and measurements of a specific job or all jobs in the memory.</p> <p> Deleting the memory cannot be undone. After confirming the message all data is permanently deleted.</p>
Memory Statistics	Displays job specific memory information such as the number of stored stations and fixpoints within a job, the number of recorded data blocks, for example measured points, or codes within a job, and the memory space occupied.

Menu item	Description
USB-File Manager	To view, delete, rename and create folders and files stored on the USB memory stick. Only available if the instrument is fitted with a Communication side cover and a USB memory stick is inserted. Refer to "10.4 Working with a USB Memory Stick" and "Appendix B Directory Structure".

Next step

- Either, select a menu option using **F1 - F4**.
- Or, press **ESC** to return to the **MAIN MENU**.

10.2

Exporting Data

Description

Job data, format files, configuration sets and codelists can be exported from the internal memory of the instrument. Data can be exported via:

The RS232 serial interface

A receiver, such as a laptop, is connected to the RS232 port. The receiver requires FlexOffice or another third party software.



If the receiver is too slow in processing data the data could be lost. With this type of data transfer the instrument is not informed about the performance of the receiver (no protocol). Therefore the success of this type of transfer is not checked.

The USB device port

For instruments fitted with a Communication side cover.

The USB device can be connected to the USB device port housed in the Communication side cover. The USB device requires FlexOffice or another third party software.

A USB memory stick

For instruments fitted with a Communication side cover. A USB memory stick can be inserted and removed from the USB host port housed in the Communication side cover. No additional software is required for the transfer.

Access

1. Select **Transfer** from the **MAIN MENU**.
2. Select **Export Data**.

DATA EXPORT

DATA EXPORT	
To	: USB-Stick
Data Type	: Measurements
Job	: Single Job
Select Job	: J101
PREV SEARCH LIST OK	

SEARCH

To search for jobs or formats within the internal memory.

LIST

To list all jobs or formats within the internal memory.

Field	Description
To	USB memory stick or RS232 serial interface.

Field	Description
Data Type	Data type to be transferred. Measurements, Fixpoints, Meas. & Fixpoints, Road Data, Code, Format, Configuration, or Backup.
Job	Select whether to export all job related data or a single job data file.
Select Job	Displays the selected job or road alignment file.
Format	If Data Type: Format Select whether to export all formats or a single format.
Formatname	If Format: Single Format Name of the format to be transferred.

Next step

1. Press **OK**.
2. If export is to a USB memory stick, select the desired file location and press **OK**.

Data type Default folder on USB memory stick

Job data:	Jobs
Format files:	Formats
Codes:	Codes
Configurations:	System
Backup:	Backup

3. Enter the file name and press **OK** or **SEND**.



Road data, Format and **Backup** are only available for data exports to a USB memory stick, not via the RS232 serial interface.



All jobs, formats, codelists and configurations will be stored in the backup folder created on the USB memory stick. The job data will be stored as individual database files for each job, which can then be imported again. Refer to "10.3 Importing Data".

Exportable job data formats

Job data can be exported from a job in dxf, gsi and xml file types, or any other user defined ASCII format. A format is defined in FlexOffice Format Manager. Refer to the online help of FlexOffice for information on creating format files.

RS232 example job data output

Within the **Data Type** setting **Measurements**, a data set could be shown as follows:

11....+00000D19	21..022+16641826	22..022+09635023
31..00+00006649	58..16+00000344	81..00+00003342
82..00-00005736	83..00+00000091	87..10+00001700

GSI-IDs			GSI-IDs continued		
11	△	PtID	41-49	△	Codes and attributes
21	△	Horizontal direction	51	△	ppm [mm]
22	△	Vertical angle	58	△	Prism constants
25	△	Orientation	81-83	△	(E, N, H) Target point
31	△	Slope distance	84-86	△	(E, N, H) Station point
32	△	Horizontal distance	87	△	Reflector height

GSI-IDs		GSI-IDs continued	
33	△	Height difference	88
			△
			Instrument height

10.3

Importing Data

Description

For instruments fitted with a Communication side cover, data can be imported to the internal memory of the instrument via a USB memory stick.

Importable data formats

When importing data, the instrument automatically stores the file in a directory folder based on the file extension. The following data formats can be imported:

File extension	Recognised as	Saved in folder
.gsi, .gsi (road)	Job data	Jobs
.dxf	Job data	Jobs
.XML	Job data	Jobs
.frt	Format file	Formats
.cls	Codelist file	Codes
.cfg	Configuration file	System

Access

1. Select **Transfer** from the **MAIN MENU**.
2. Select **Import Data**.

DATA IMPORT

DATA IMPORT			
From:	USB-Stick		
To :	Instrument		
File:	Single File		
PREV			OK

Field	Description
From	USB-Stick
To	Instrument
File	Import a single file or a backup folder.



Import data step-by-step

Importing a backup folder will overwrite the existing configuration file and code lists on the instrument, and all existing formats and jobs will be deleted.

1. Press **OK** in the **DATA IMPORT** screen to proceed to the USB memory stick file directory
2. Select the file or backup folder on the USB memory stick to be imported and press **OK**.

3. For a file: Define the name for the imported file, and, if requested, the file definition and layers, and press **OK** to import.
For a backup folder: Take note of the warning message displayed and press **OK** to proceed and import the folder.
4. A message will display once the file or backup folder has been successfully imported.

10.4

Insert a USB memory stick step- by-step

Working with a USB Memory Stick

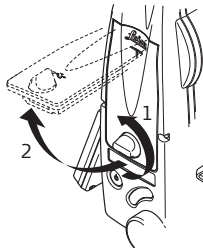

Open the compartment lid on the Communication side cover.

The USB host port is located underneath the top edge of the compartment.

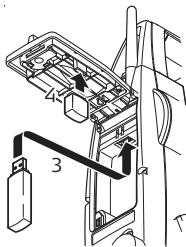

Insert the USB memory stick into the USB host port.

The cap of a Leica industrial grade USB memory stick can be stored on the underside of the compartment lid.

Close the compartment lid and turn the knob to lock the compartment closed.



Always return to the **MAIN MENU** before removing the USB memory stick.



Whilst other USB memory sticks may be used, Leica Geosystems recommends Leica industrial grade USB memory sticks and cannot be held responsible for data loss or any other error that may occur when using a non-Leica USB memory stick.



- Keep the USB memory stick dry.
- Use it only within the specified temperature range, -40°C to +85°C (-40°F to +185°F).
- Protect the USB memory stick from direct impacts.

Failure to follow these instructions could result in data loss and/or permanent damage to the USB memory stick.

Format a USB memory stick step-by-step

Formatting the USB memory stick before starting to store data is required if a completely new USB memory stick is used, or if all existing data needs to be deleted.



The formatting function on the instrument only works for Leica USB memory sticks. All other USB memory sticks should be formatted on a computer.

1. Select **Manage** from the **MAIN MENU**.
2. Select **USB-File Manager** from the **FILE MANAGEMENT** menu.
3. Press **↓ FORMAT** in the **USB-File Manager** screen.
4. A warning message will appear.



By activating the format command all data will be lost. Make sure that all important data on the USB memory stick has been backed up before formatting the USB memory stick.

5. Press **YES** to format the USB memory stick.

A message will display once the formatting of the USB memory stick is completed. Press **OK** to return to the **USB-File Manager** screen.

10.5

Working with Bluetooth

Description

Instruments fitted with a Communication side cover can communicate with external devices via a Bluetooth connection. The instrument Bluetooth is a slave only. The Bluetooth of the external device will be the master, and therefore will control the connection and any data transfer.

Establishing a connection step-by-step

1. On the instrument ensure that the communication parameters are set to **Bluetooth** and **Active**. Refer to "4.3 Communication Parameters".
2. Activate Bluetooth on the external device. The steps required depend on the Bluetooth driver and other device specific configurations. Refer to the device user manual for information on how to configure and search for a Bluetooth connection.

The instrument will appear on the external device as "TS0x_y_zzzzzz", where x = the FlexLine series (TS02, TS06 or TS09), y = the angular accuracy in arc seconds, and z = the serial number of the instrument. For example, TS02_3_1234567.

3. Some devices ask for the identification number of the Bluetooth. The default number for a FlexLine Bluetooth is 0000. This can be changed by:
 - a. Select **Settings** from the **MAIN MENU**.
 - b. Select **Comm** from the **SETTINGS MENU**.
 - c. Press **BT-PIN** from the **COMMUNICATION PARAMETER** screen.
 - d. Enter a new Bluetooth PIN number in **PIN-Code**:
 - e. Press **OK** to confirm the new Bluetooth PIN.
4. When the external Bluetooth device has located the instrument for the first time, a message will display on the instrument stating the name of the external device and requesting confirmation that connection to this device should be allowed.
 - Press **YES** to allow, or
 - Press **NO** to disallow this connection
5. The instrument Bluetooth sends out the instrument name and serial number to the external Bluetooth device.
6. All further steps must be made in accordance to the user manual of the external device.

Transferring data via Bluetooth

Using FlexOffice Data Exchange Manager, data files can be transferred from the instrument to a local folder via the Bluetooth connection. The transfer is made through the serial port configured on the computer as the Bluetooth Serial Port, however, for faster data transfer speeds we recommend using the USB or RS232 connections.

For more information about FlexOffice Data Exchange Manager refer to the comprehensive online help.

For transferring data using other external devices or software programs, refer to the user manual of the device or software. The FlexLine Bluetooth does not establish or manage the data transfer.

10.6**Working with Leica FlexOffice****Description**

The program package FlexOffice is used for the data exchange between the instrument and a computer. It contains several auxiliary programs in order to support the instrument.

Installation on a computer

The installation program can be found on the CD-ROM supplied. Insert the CD and follow the on-screen instructions. Please note that FlexOffice can only be installed on computers with MS Windows 2000, XP and Vista operating systems.



For more information about FlexOffice refer to the comprehensive online help.

11

Check & Adjust

11.1

Overview

Description

Leica Geosystems instruments are manufactured, assembled and adjusted to the best possible quality. Quick temperature changes, shock or stress can cause deviations and decrease the instrument accuracy. It is therefore recommended to check and adjust the instrument from time to time. This can be done in the field by running through specific measurement procedures. The procedures are guided and have to be followed carefully and precisely as described in the following chapters. Some other instrument errors and mechanical parts can be adjusted mechanically.

Electronic adjustment

The following instrument errors can be checked and adjusted electronically:

- Horizontal collimation error, also called line-of-sight error.
 - Vertical index error, and simultaneously the electronic level.
 - Tilting axis error.
-



For determining these errors, it is necessary to measure in both faces, but the procedure can be started in any face.

Mechanical adjustment

The following instrument parts can be adjusted mechanically:

- Circular level on the instrument and tribrach.
 - Laser plummet.
 - Screws on the tripod.
-



During the manufacturing process, the instrument errors are carefully determined and set to zero. As mentioned, these errors can change and it is highly recommended to redetermine them in the following situations:

- Before the instrument is used for the first time.
- Before every high precision survey.
- After rough or long periods of transport.
- After long periods of work or storage.
- If the temperature difference between current environment and the temperature at the last calibration is more than 10°C (18°F).

11.2

Preparation



Before determining the instrument errors, level-up the instrument using the electronic level. The **Level/Plummet** is the first screen to appear after turning on the instrument.

The tribrach, the tripod and the ground should be very stable and secure from vibrations or other disturbances.



The instrument should be protected from direct sunlight in order to avoid thermal expansion on one side only.



Before starting to work, the instrument has to become acclimatised to the ambient temperature. Approximately two minutes per °C of temperature difference from storage to working environment, but at least 15 min, should be taken into account.

11.3

Adjusting Line-of-Sight and Vertical Index Error

Line-of-sight error

The line-of-sight error, or horizontal collimation error is the deviation from the perpendicular between the tilting axis and the line of sight. The effect of the line-of-sight error to the horizontal direction increases with the vertical angle.

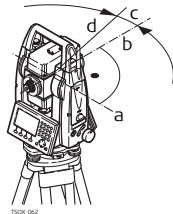

- a Tilting axis
 - b Line perpendicular to tilting axis
 - c Horizontal collimation, or line-of-sight, error
 - d Line-of-sight
-

Vertical index error The vertical circle should read exactly 90° (100 gon) when the line of sight is horizontal. Any deviation from this figure is termed vertical index error. This is a constant error that affects all vertical angle readings.

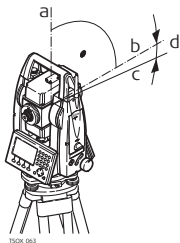

- a Mechanical vertical axis of the instrument, also called standing axis
- b Axis perpendicular to the vertical axis. True 90°
- c Vertical angle is reading 90°
- d Vertical index error



By determining the vertical index error the electronic level is adjusted automatically

Access

1. Select **Tools** from the **MAIN MENU**.
 2. Select **Adjust** from the **TOOLS MENU**.
- Select:
 - **HZ-collimation**, or
 - **V-Index**.



The procedures and conditions required to correct line-of-sight and vertical index errors are the same, therefore the procedure will only be described once.

Check and adjust step-by-step

1. Level the instrument with the electronic level. Refer to "3 Operation"- "Level up with the electronic level step-by-step".

2.

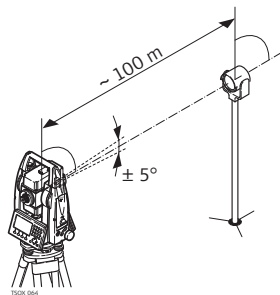

Aim at a point approximately 100 m from the instrument which is within 5° of the horizontal.

3. Press **REC** to measure to the target point.

4.

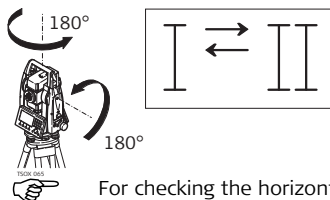

Change face and aim at the target point again

For checking the horizontal aim, the difference in Hz and V are displayed.

5. Press **REC** to measure to the target point.



The old and new calculated values are displayed.

6. Either:

- Press **MORE** to measure another set to the same target point. The final adjustment values will be the calculated average from all the measurements.
- Press **OK** to save the new adjustment data, or
- Press **ESC** to exit without saving the new adjustment data.

Messages

The following are important messages or warnings that may appear.

Messages	Description
V-angle not suitable for adjustment !	The vertical angle deviates from the required horizontal / line-of-sight, or in face II the vertical angle deviates by more than 5° from the target point. Aim at the target point with an accuracy of min. 5° or, when adjusting the tilt axis, 27° above or beneath the horizontal plane. Confirmation of the message required.
Results out of tolerance. Previous values retained !	Computed values out of tolerance. The previous values are retained and measurements should be repeated. Confirmation of the message required.
Hz-angle not suitable for adjustment !	Horizontal angle in face II deviates by more than 5° from the target point. Aim on the target point with an accuracy of min. 5°. Confirmation of the message required.

Messages	Description
Measurement Error. Try again.	Measurement error appears when, for example, there is an unstable set up. Repeat the process. Confirmation of the message required.
Time limit exceeded ! Please repeat adjustment !	Time difference between measurements for results storage exceeds 15 minutes. Repeat the process. Confirmation of the message required.

11.4

Adjusting the Tilting Axis Error

Description

The tilting axis error is caused by the deviation between the mechanical tilting axis and the line perpendicular to the vertical axis. This error affects horizontal angles. To determine this error, it is necessary to point to a target located significantly below or above the horizontal plane.



Access

The horizontal collimation error has to be determined before starting this procedure.

1. Select **Tools** from the **MAIN MENU**.
2. Select **Adjust** from the **TOOLS MENU**.
3. Select **Tilt Axis**.

**Check and adjust
step-by-step**

1. Level the instrument with the electronic level. Refer to "3 Operation"- "Level up with the electronic level step-by-step".

- 2.

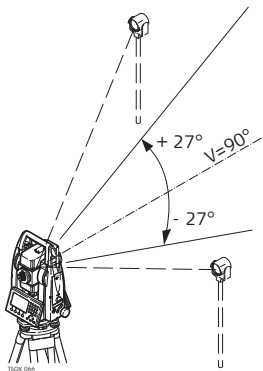

Aim at a point approximately 100 m from the instrument which is at least 27° (30 gon) above or beneath the horizontal plane.

3. Press **REC** to measure to the target point.

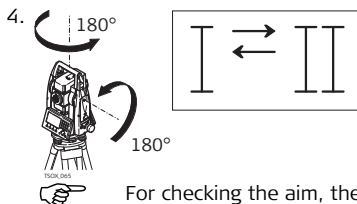

Change face and aim at the target point again

For checking the aim, the difference in Hz and V are displayed.

5. Press **REC** to measure to the target point.



The old and new calculated values are displayed.

6. Either:

- Press **MORE** to measure another set to the same target point. The final adjustment values will be the calculated average from all the measurements.
- Press **OK** to save the new adjustment data, or
- Press **ESC** to exit without saving the new adjustment data.

Messages

The same messages or warning as in "11.3 Adjusting Line-of-Sight and Vertical Index Error" may appear.

11.5

Adjusting the Circular Level of the Instrument and Tribrach

Adjust the circular level step-by-step

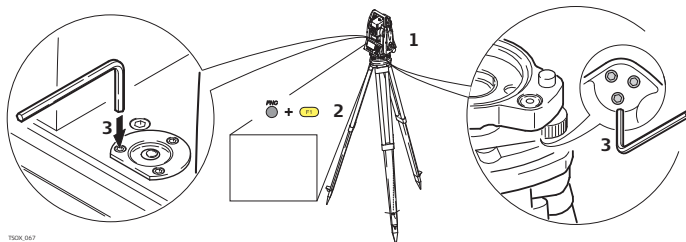

TSDM_067

1. Place and secure the tribrach onto the tripod, and then secure the instrument onto the tribrach.
2. Using the tribrach footscrews, level the instrument with the electronic level. To activate the electronic level, turn on the instrument, and, if tilt correction is set to 1- or 2-axis, the **Level/Plummet** screen appears automatically. Alternatively, press **FNC** from within any application and select **Level/Plummet**.
3. The bubbles of the instrument and tribrach levels must be centered. If one or both circular levels are not centered, adjust as follows.

Instrument: If the bubble extends beyond the circle, use the Allen key supplied to center it with the adjustment screws.

Tribrach: If the bubble extends beyond the circle, adjust it using the adjustment pin in conjunction with the adjustment screws. Turn the adjustment screws:

- To the left: and the bubble approaches the screw.

- To the right: and the bubble goes away from the screw.
4. Repeat step 3. on the instrument and tribrach until both circular levels are centered and no further adjustments are necessary.



After the adjustment, no adjustment screw should be loose.

11.6



Inspecting the Laser Plummet of the Instrument

The laser plummet is integrated into the vertical axis of the instrument. Under normal conditions of use, the laser plummet does not need adjusting. If an adjustment is necessary due to external influences, the instrument has to be returned to a Leica service department.

Inspect the laser plummet step-by-step

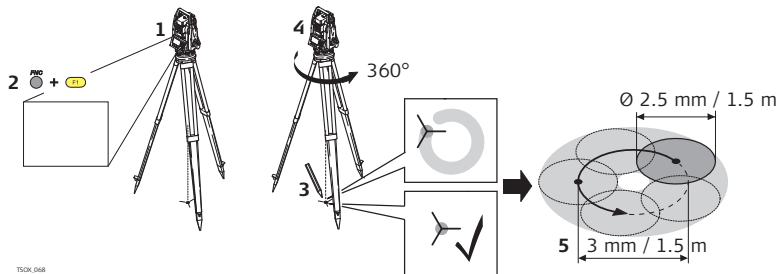

1. Set up the instrument on the tripod approximately 1.5 m above the ground and level up.
2. To activate the laser plummet, turn on the instrument, and, if tilt correction is set to 1- or 2-axis, the laser plummet will be activated automatically, and the **Level/Plummet** screen appears. Otherwise, press **FNC** from within any application and select **Level/Plummet**.



Inspection of the laser plummet should be carried out on a bright, smooth and horizontal surface, such as a sheet of paper.

3. Mark the center of the red laser dot on the ground.
4. Turn the instrument slowly through 360°, carefully observing the movement of the red laser dot.



The maximum diameter of the circular movement described by the center of the laser dot should not exceed 3 mm at a height of 1.5 m.

5. If the center of the laser dot makes a clearly circular movement, or moves more than 3 mm away from the point which was first marked, an adjustment may be required. Call your nearest Leica service department.

Depending on brightness and surface type, the size of the laser dot can vary. At a height of 1.5 m an average diameter of 2.5 mm is estimated.

11.7

Service the tripod step-by-step

Servicing the Tripod

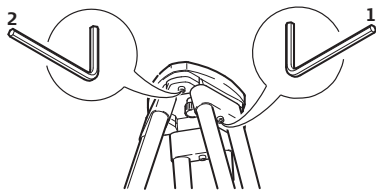

TSOK_122



The connections between metal and timber components must always be firm and tight.

1. Tighten the leg cap screws moderately with the allen key supplied.
2. Tighten the articulated joints on the tripod head just enough to keep the tripod legs open when lifting the tripod off the ground.
3. Tighten the screws of the tripod legs.

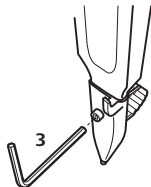

12 Care and Transport

12.1 Transport

Transport in the field

When transporting the equipment in the field, always make sure that you either:

- carry the product in its original transport container, or
 - carry the tripod with its legs splayed across your shoulder, keeping the attached product upright.
-

Transport in a road vehicle

Never carry the product loose in a road vehicle, as it can be affected by shock and vibration. Always carry the product in its transport container and secure it.

Shipping

When transporting the product by rail, air or sea, always use the complete original Leica Geosystems packaging, transport container and cardboard box, or its equivalent, to protect against shock and vibration.

Shipping, transport of batteries

When transporting or shipping batteries, the person in charge of the product must ensure that the applicable national and international rules and regulations are observed. Before transportation or shipping, contact your local passenger or freight transport company.

Field adjustment

After transport inspect the field adjustment parameters given in this user manual before using the product.

12.2

Storage

Product

Respect the temperature limits when storing the equipment, particularly in summer if the equipment is inside a vehicle. Refer to "14 Technical Data" for information about temperature limits.

Field adjustment

After long periods of storage inspect the field adjustment parameters given in this user manual before using the product.

Li-Ion batteries

- Refer to "14.6 General Technical Data of the Instrument" for information about storage temperature range.
 - Batteries can be stored within a -40 to +55°C/-40°F to +131°F temperature range, however a storage temperature range of -20°C to +30°C/-4°F to +86°F in a dry environment is recommended to minimise self-discharging of the battery.
 - At the recommended storage temperature range, batteries containing a 10% to 50% charge can be stored for up to one year. After this storage period the batteries must be recharged.
 - Remove batteries from the product and the charger before storing.
 - After storage recharge batteries before using.
 - Protect batteries from damp and wetness. Wet or damp batteries must be dried before storing or use.
-

12.3

Cleaning and Drying

Objective, eyepiece and reflectors

- Blow dust off lenses and prisms.
 - Never touch the glass with your fingers.
 - Use only a clean, soft, lint-free cloth for cleaning. If necessary, moisten the cloth with water or pure alcohol. Do not use other liquids; these may attack the polymer components.
-

Fogging of prisms

Prisms that are cooler than the ambient temperature tend to fog. It is not enough simply to wipe them. Keep them for some time inside your jacket or in the vehicle to allow them to adjust to the ambient temperature.

Damp products

Dry the product, the transport container, the foam inserts and the accessories at a temperature not greater than 40°C /104°F and clean them. Do not repack until everything is completely dry. Always close the transport container when using in the field.

Cables and plugs

Keep plugs clean and dry. Blow away any dirt lodged in the plugs of the connecting cables.

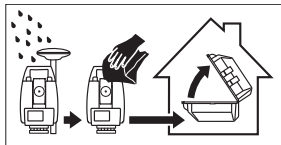

13

Safety Directions

13.1

General

Description

The following directions should enable the person responsible for the product, and the person who actually uses the equipment, to anticipate and avoid operational hazards.

The person responsible for the product must ensure that all users understand these directions and adhere to them.

13.2

Intended Use

Permitted use

- Measuring horizontal and vertical angles.
 - Measuring distances.
 - Recording measurements.
 - Visualizing the aiming direction and vertical axis.
 - Data communication with external appliances.
 - Computing by means of software.
-

Adverse use

- Use of the product without instruction.
- Use outside of the intended limits.
- Disabling safety systems.
- Removal of hazard notices.

- Opening the product using tools, for example screwdriver, unless this is specifically permitted for certain functions.
 - Modification or conversion of the product.
 - Use after misappropriation.
 - Use of products with obviously recognisable damages or defects.
 - Use with accessories from other manufacturers without the prior explicit approval of Leica Geosystems.
 - Aiming directly into the sun.
 - Inadequate safeguards at the working site, for example when measuring on roads.
 - Deliberate dazzling of third parties.
 - Controlling of machines, moving objects or similar monitoring application without additional control- and safety installations.
-

 **Warning**

Adverse use can lead to injury, malfunction and damage.

It is the task of the person responsible for the equipment to inform the user about hazards and how to counteract them. The product is not to be operated until the user has been instructed on how to work with it.

13.3

Environment



Danger

Limits of Use

Suitable for use in an atmosphere appropriate for permanent human habitation: not suitable for use in aggressive or explosive environments.

Local safety authorities and safety experts must be contacted before working in hazardous areas, or in close proximity to electrical installations or similar situations by the person in charge of the product.

13.4

Manufacturer of the product

Responsibilities

Leica Geosystems AG, CH-9435 Heerbrugg, hereinafter referred to as Leica Geosystems, is responsible for supplying the product, including the user manual and original accessories, in a completely safe condition.

Manufacturers of non Leica Geosystems accessories

The manufacturers of non Leica Geosystems accessories for the product are responsible for developing, implementing and communicating safety concepts for their products, and are also responsible for the effectiveness of those safety concepts in combination with the Leica Geosystems product.

Person in charge of the product

The person in charge of the product has the following duties:

- To understand the safety instructions on the product and the instructions in the user manual.
- To be familiar with local regulations relating to safety and accident prevention.
- To inform Leica Geosystems immediately if the product and the application becomes unsafe.

- To ensure that the national laws, regulations and conditions for the operation of radio transmitters are respected.
-

**Warning**

The person responsible for the product must ensure that it is used in accordance with the instructions. This person is also accountable for the training and the deployment of personnel who use the product and for the safety of the equipment in use.

13.5

Hazards of Use

**Warning**

The absence of instruction, or the inadequate imparting of instruction, can lead to incorrect or adverse use, and can give rise to accidents with far-reaching human, material, financial and environmental consequences.

Precautions:

All users must follow the safety directions given by the manufacturer and the directions of the person responsible for the product.

**Caution**

Watch out for erroneous measurement results if the product has been dropped or has been misused, modified, stored for long periods or transported.

Precautions:

Periodically carry out test measurements and perform the field adjustments indicated in the user manual, particularly after the product has been subjected to abnormal use and before and after important measurements.

 **Danger**

Because of the risk of electrocution, it is very dangerous to use poles and extensions in the vicinity of electrical installations such as power cables or electrical railways.

Precautions:

Keep at a safe distance from electrical installations. If it is essential to work in this environment, first contact the safety authorities responsible for the electrical installations and follow their instructions.



 **Warning**

If the product is used with accessories, for example masts, staffs, poles, you may increase the risk of being struck by lightning.

Precautions:





Do not use the product in a thunderstorm.

 **Caution**

Be careful when pointing the product towards the sun, because the telescope functions as a magnifying glass and can injure your eyes and/or cause damage inside the product.

Precautions:

Do not point the product directly at the sun.

-
-  **Warning** During dynamic applications, for example stakeout procedures there is a danger of accidents occurring if the user does not pay attention to the environmental conditions around, for example obstacles, excavations or traffic.
Precautions:
The person responsible for the product must make all users fully aware of the existing dangers.
-
-  **Warning** Inadequate securing of the working site can lead to dangerous situations, for example in traffic, on building sites, and at industrial installations.
Precautions:
Always ensure that the working site is adequately secured. Adhere to the regulations governing safety and accident prevention and road traffic.
-
-  **Warning** If computers intended for use indoors are used in the field there is a danger of electric shock.
Precautions:
Adhere to the instructions given by the computer manufacturer with regard to field use in conjunction with Leica Geosystems products.
-
-  **Caution** If the accessories used with the product are not properly secured and the product is subjected to mechanical shock, for example blows or falling, the product may be damaged or people may sustain injury.
Precautions:
When setting-up the product, make sure that the accessories are correctly adapted, fitted, secured, and locked in position.
Avoid subjecting the product to mechanical stress.

 **Caution**

During the transport, shipping or disposal of batteries it is possible for inappropriate mechanical influences to constitute a fire hazard.

Precautions:

Before shipping the product or disposing of it, discharge the batteries by running the product until they are flat.

When transporting or shipping batteries, the person in charge of the product must ensure that the applicable national and international rules and regulations are observed. Before transportation or shipping contact your local passenger or freight transport company.

 **Warning**

Using a battery charger not recommended by Leica Geosystems can destroy the batteries. This can cause fire or explosions.

Precautions:

Only use chargers recommended by Leica Geosystems to charge the batteries.

 **Warning**

High mechanical stress, high ambient temperatures or immersion into fluids can cause leakage, fire or explosions of the batteries.

Precautions:

Protect the batteries from mechanical influences and high ambient temperatures. Do not drop or immerse batteries into fluids.

 **Warning**

Short circuited battery terminals can overheat and cause injury or fire, for example by storing or transporting in pockets if battery terminals come in contact with jewellery, keys, metallized paper or other metals.

Precautions:

Make sure that the battery terminals do not come into contact with metallic objects.

 **Warning**

If the product is improperly disposed of, the following can happen:

- If polymer parts are burnt, poisonous gases are produced which may impair health.
- If batteries are damaged or are heated strongly, they can explode and cause poisoning, burning, corrosion or environmental contamination.
- By disposing of the product irresponsibly you may enable unauthorised persons to use it in contravention of the regulations, exposing themselves and third parties to the risk of severe injury and rendering the environment liable to contamination.
- Improper disposal of silicone oil may cause environmental contamination.

Precautions:

The product must not be disposed with household waste.

Dispose of the product appropriately in accordance with the national regulations in force in your country.

Always prevent access to the product by unauthorised personnel.

Product specific treatment and waste management information can be downloaded from the Leica Geosystems home page at <http://www.leica-geosystems.com/treatment> or received from your Leica Geosystems dealer.

13.6

13.6.1

General

Laser Classification

General

The following directions (in accordance with the state of the art - international standard IEC 60825-1 (2007-03) and IEC TR 60825-14 (2004-02)) provide instruction and training information to the person responsible for the product and the person who actually uses the equipment, to anticipate and avoid operational hazards.

The person responsible for the product must ensure that all users understand these directions and adhere to them.



Products classified as laser class 1, class 2 and class 3R do not require:

- laser safety officer involvement,
- protective clothes and eyewear,
- special warning signs in the laser working area

if used and operated as defined in this user manual due to the low eye hazard level.



Products classified as laser class 2 or class 3R may cause dazzle, flash-blindness and afterimages, particularly under low ambient light conditions.

13.6.2

Distancer, Measurements with Reflectors

General

The EDM module built into this product produces a visible laser beam which emerges from the telescope objective.

The laser product described in this section, is classified as laser class 1 in accordance with:

- IEC 60825-1 (2007-03): "Safety of laser products".
- EN 60825-1 (2007-10): "Safety of laser products".

Class 1 laser products are safe under reasonably foreseeable conditions of operation and are not harmful to the eyes provided that the products are used and maintained in accordance with this user manual.

Description	Value
Maximum average radiant power	0.33 mW
Pulse duration	800 ps
Pulse repetition frequency	100 MHz - 150 MHz
Wavelength	650 nm - 690 nm

13.6.3

Distancer, Measurements without Reflectors (Non-Prism mode)

General

The EDM module built into the product produces a visible laser beam which emerges from the telescope objective.

The laser product described in this section is classified as laser class 3R in accordance with:

- IEC 60825-1 (2007-03): "Safety of laser products".
- EN 60825-1 (2007-10): "Safety of laser products".

Class 3R laser products:

Direct intrabeam viewing may be hazardous (low-level eye hazard), in particular for deliberate ocular exposure. The risk of injury for laser class 3R products is limited because of:

- unintentional exposure would rarely reflect worst case conditions of (e.g.) beam alignment with the pupil, worst case accommodation,
- inherent safety margin in the maximum permissible exposure to laser radiation (MPE), natural aversion behaviour for exposure to bright light for the case of visible radiation.

Description	Value (R400/R1000)
Maximum average radiant power	5.00 mW
Pulse duration	800 ps
Pulse repetition frequency	100 MHz - 150 MHz
Wavelength	650 nm - 690 nm
Beam divergence	0.2 mrad x 0.3 mrad
NOHD (Nominal Ocular Hazard Distance) @ 0.25s	80 m / 262 ft

 **Warning**

From a safety perspective class 3R laser products should be treated as potentially hazardous.

Precautions:

Prevent direct eye exposure to the beam. Do not direct the beam at other people.

 **Warning**

Potential hazards are not only related to direct beams but also to reflected beams aimed at reflecting surfaces such as prisms, windows, mirrors, metallic surfaces etc.

Precautions:

Do not aim at areas that are essentially reflective, such as a mirror, or which could emit unwanted reflections.

Do not look through or beside the optical sight at prisms or reflecting objects when the laser is switched on, in laser pointer or distance measurement mode. Aiming at prisms is only permitted when looking through the telescope.

Labelling

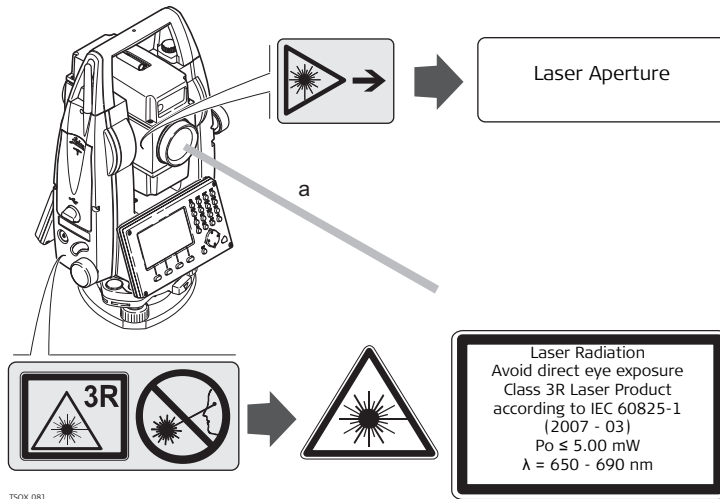

TSOX_081

a Laser beam

.....

.....

.....



.....

.....

.....

.....

.....



Complies with FDA performance standards for laser products except for deviations pursuant to Laser Notice No. 50, dated June 24, 2007.

This device complies with part 15 of the FCC Rules.

Operation is subject to the following two conditions:

(1) This device may not cause harmful interference, and

(2) this device must accept any interference received, including interference that may cause undesired operation.

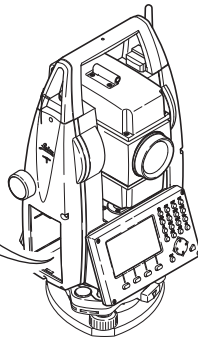

TS0X_082

13.6.4

Electronic Guide Light EGL

General

The integrated Electronic Guide Light produces a visible LED beam from the front side of the telescope. Depending on the type of telescope the EGL may be designed differently.



The product described in this section, is excluded from the scope of IEC 60825-1 (2007-03): "Safety of laser products".

The product described in this section, is classified as exempt group in accordance with IEC 62471 (2006-07) and does not pose any hazard provided that the product is used and maintained in accordance with this user manual.

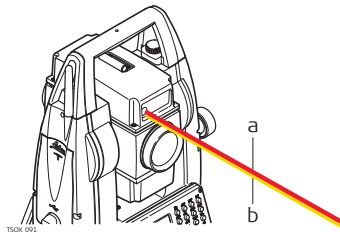

TSOK_091

- a LED beam red
- b LED beam yellow

13.6.5

Laser Plummet

General

The laser plummet built into the product produces a visible red laser beam which emerges from the bottom of the product.

The laser product described in this section, is classified as laser class 2 in accordance with:

- IEC 60825-1 (2007-03): "Safety of laser products".

Class 2 laser products:

These products are safe for momentary exposures but can be hazardous for deliberate staring into the beam.

Description	Value
Maximum average radiant power	1.00 mW
Pulse duration	0-100%
Pulse repetition frequency	1 kHz
Wavelength	620 nm - 690 nm



From a safety perspective class 2 laser products are not inherently safe for the eyes.

Precautions:

Avoid staring into the beam or pointing the beam at other people.

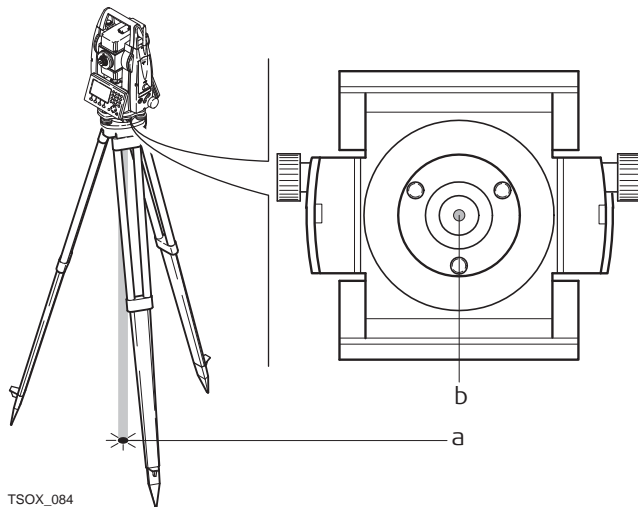

TSOX_084

- a Laser beam
- b Exit for laser beam

13.7

Electromagnetic Compatibility EMC

Description

The term Electromagnetic Compatibility is taken to mean the capability of the product to function smoothly in an environment where electromagnetic radiation and electrostatic discharges are present, and without causing electromagnetic disturbances to other equipment.

Warning

Electromagnetic radiation can cause disturbances in other equipment.

Although the product meets the strict regulations and standards which are in force in this respect, Leica Geosystems cannot completely exclude the possibility that other equipment may be disturbed.

Caution

There is a risk that disturbances may be caused in other equipment if the product is used in conjunction with accessories from other manufacturers, for example field computers, personal computers, two-way radios, non-standard cables or external batteries.

Precautions:

Use only the equipment and accessories recommended by Leica Geosystems. When combined with the product, they meet the strict requirements stipulated by the guidelines and standards. When using computers and two-way radios, pay attention to the information about electromagnetic compatibility provided by the manufacturer.

Caution

Disturbances caused by electromagnetic radiation can result in erroneous measurements.

Although the product meets the strict regulations and standards which are in force in this respect, Leica Geosystems cannot completely exclude the possibility that the product may be disturbed by very intense electromagnetic radiation, for example, near radio transmitters, two-way radios or diesel generators.

Precautions:

Check the plausibility of results obtained under these conditions.



If the product is operated with connecting cables attached at only one of their two ends, for example external supply cables, interface cables, the permitted level of electromagnetic radiation may be exceeded and the correct functioning of other products may be impaired.

Precautions:

While the product is in use, connecting cables, for example product to external battery, product to computer, must be connected at both ends.

Bluetooth

Use of product with Bluetooth:



Electromagnetic radiation can cause disturbances in other equipment, in installations, in medical devices, for example pacemakers or hearing aids and in aircraft. It can also affect humans and animals.

Precautions:

Although the product meets in combination with radio or digital cellular phone devices recommended by Leica Geosystems the strict regulations and standards which are in force in this respect, Leica Geosystems cannot completely exclude the possibility that other equipment may be disturbed or that humans or animals may be affected.

- Do not operate the product with radio or digital cellular phone devices in the vicinity of filling stations or chemical installations, or in other areas where an explosion hazard exists.
- Do not operate the product with radio or digital cellular phone devices near to medical equipment.
- Do not operate the product with radio or digital cellular phone devices in aircraft.

13.8

FCC Statement, Applicable in U.S.

Applicability

The greyed paragraph below is only applicable for FlexLine instruments without Bluetooth.



Warning

This equipment has been tested and found to comply with the limits for a Class B digital device, pursuant to part 15 of the FCC rules.

These limits are designed to provide reasonable protection against harmful interference in a residential installation.

This equipment generates, uses and can radiate radio frequency energy and, if not installed and used in accordance with the instructions, may cause harmful interference to radio communications. However, there is no guarantee that interference will not occur in a particular installation.

If this equipment does cause harmful interference to radio or television reception, which can be determined by turning the equipment off and on, the user is encouraged to try to correct the interference by one or more of the following measures:



- Reorient or relocate the receiving antenna.
- Increase the separation between the equipment and the receiver.
- Connect the equipment into an outlet on a circuit different from that to which the receiver is connected.
- Consult the dealer or an experienced radio/TV technician for help.

 **Warning**

Changes or modifications not expressly approved by Leica Geosystems for compliance could void the user's authority to operate the equipment.

Labelling FlexLine instrument

.....
.....
.....
.....
.....

 

Complies with FDA performance standards for laser products except for deviations pursuant to Laser Notice No. 50, dated June 24, 2007.
This device complies with part 15 of the FCC Rules.
Operation is subject to the following two conditions:
(1) This device may not cause harmful interference, and
(2) this device must accept any interference received, including interference that may cause undesired operation.

TSOX_085

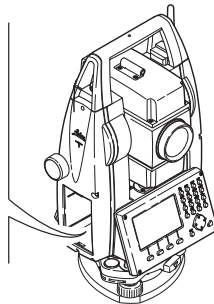

Labelling internal battery GEB211, GEB221

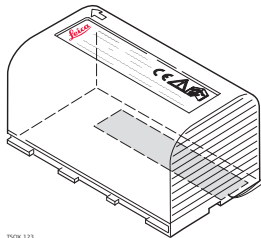

TSOK_123

This device complies with part 15 of the FCC Rules. Operation is subject to the following two conditions: (1) This device may not cause harmful interference, and (2) this device must accept any interference received, including interference that may cause undesired operation.

 US LISTED
ITE Accessory
E179078 . 70YL

14

Technical Data

14.1

Angle Measurement

Accuracy

Available angular accuracies	Standard deviation Hz, V, ISO 17123-3	Display resolution			
		["]	[°]	[mgon]	[mil]
1	0.3	1	0.0001	0.1	0.01
2	0.6	1	0.0001	0.1	0.01
3	1.0	1	0.0001	0.1	0.01
5	1.5	1	0.0001	0.1	0.01
7	2	1	0.0001	0.1	0.01

Characteristics

Absolute, continuous, diametric. Updates each 0.1 to 0.3 s.

14.2

Distance Measurement with Reflectors

Range

Reflector	Range A		Range B		Range C	
	[m]	[ft]	[m]	[ft]	[m]	[ft]
Standard prism (GPR1)	1800	6000	3000	10000	3500	12000
3 prisms (GPR1)	2300	7500	4500	14700	5400	17700
360° prism (GPZ4, GPZ122)	800	2600	1500	5000	2000	7000
Reflector tape 60 mm x 60 mm	150	500	250	800	250	800
Mini prism (GMP101)	800	2600	1200	4000	2000	7000
360° Mini prism (GRZ101)	450	1500	800	2600	1000	3300

Shortest measuring distance: 1.5 m

**Atmospheric
conditions**

Range A: Strong haze, visibility 5 km; or strong sunlight, severe heat shimmer

Range B: Light haze, visibility about 20 km; or moderate sunlight, slight heat shimmer

Range C: Overcast, no haze, visibility about 40 km; no heat shimmer

Accuracy

Accuracy refers to measurements to standard reflectors.

EDM measuring mode	Standard deviation ISO 17123-4		Measurement time, typical [s]
	TS02 / TS06	TS09	
Prism-Standard	1.5 mm + 2 ppm	1 mm + 1.5 ppm	2.4
Prism-Fast	3 mm + 2 ppm	3 mm + 1.5 ppm	0.8
Prism-Tracking	3 mm + 2 ppm	3 mm + 1.5 ppm	<0.15
Tape	5 mm + 2 ppm	5 mm + 1.5 ppm	2.4

Beam interruptions, severe heat shimmer and moving objects within the beam path can result in deviations of the specified accuracy.

Characteristics

Principle:	Phase measurement
Type:	Coaxial, visible red laser
Carrier wave:	658 nm
Measuring system:	System analyser basis 100 MHz - 150 MHz

14.3

Distance Measurement without Reflectors (Non-Prism mode)

Range

Power Pinpoint R400 (without reflector)

Kodak Gray Card	Range D		Range E		Range F	
	[m]	[ft]	[m]	[ft]	[m]	[ft]
White side, 90 % reflective	200	660	300	990	>400	>1310
Grey side, 18 % reflective	100	330	150	490	>200	>660

Ultra Pinpoint R1000 (without reflector)

Kodak Gray Card	Range D		Range E		Range F	
	[m]	[ft]	[m]	[ft]	[m]	[ft]
White side, 90 % reflective	600	1970	800	2630	>1000	>3280
Grey side, 18 % reflective	300	990	400	1310	>500	>1640

Range of Measurement: 1.5 m to 1200 m
 Range of Measurement, FlexPoint: 1.5 m to 30 m
 Display unambiguous: up to 1200 m

Atmospheric conditions

Range D: Object in strong sunlight, severe heat shimmer
 Range E: Object in shade, or overcast

Range F: Day, night and twilight

Accuracy

Standard measuring	Standard deviation ISO 17123-4	Measure time, typical [s]	Measure time, maximum [s]
0 m - 500 m	2 mm + 2 ppm	3 - 6	12
>500 m	4 mm + 2 ppm	3 - 6	12

Beam interruptions, severe heat shimmer and moving objects within the beam path can result in deviations of the specified accuracy.

Tracking measuring*	Standard deviation	Measure time, typical [s]
Tracking	5 mm + 3 ppm	0.25

* Accuracy and measure time depend on atmospheric conditions, target object and observation situation.

Characteristics

Type: Coaxial, visible red laser
Carrier wave: 658 nm
Measuring system: System analyser basis 100 MHz - 150 MHz

Laser dot size

Distance [m]	Laser dot size, approximately [mm]
at 30	7 x 10
at 50	8 x 20

14.4

Distance Measurement Reflector (>3.5 km)

Range

Ultra&Power (with reflector)	Range A		Range B		Range C	
	[m]	[ft]	[m]	[ft]	[m]	[ft]
Standard prism (GPR1)	2200	7300	7500	24600	>10000	>33000
Reflector tape 60 mm x 60 mm	600	2000	1000	3300	1300	4200

Range of measurement: From 1000 m up to 12000 m

Display unambiguous: Up to 12 km

Atmospheric conditions

Range A: Strong haze, visibility 5 km; or strong sunlight, severe heat shimmer

Range B: Light haze, visibility about 20 km; or moderate sunlight, slight heat shimmer

Range C: Overcast, no haze, visibility about 40 km; no heat shimmer

Accuracy

Standard measuring	Standard deviation ISO 17123-4	Measure time, typical [s]	Measure time, maximum [s]
Long range	5 mm + 2 ppm	2.5	12

Beam interruptions, severe heat shimmer and moving objects within the beam path can result in deviations of the specified accuracy.

Characteristics

Principle:	Phase measurement
Type:	Coaxial, visible red laser
Carrier wave:	658 nm
Measuring system:	System analyser basis 100 MHz - 150 MHz

14.5**Conformity to National Regulations****14.5.1****Products without Communication side cover**

Conformity to national regulations

Hereby, Leica Geosystems AG, declares that the instrument is in compliance with the essential requirements and other relevant provisions of applicable European Directives. The declaration of conformity may be consulted at <http://www.leica-geosystems.com/ce>.

14.5.2

Conformity to national regulations

Products with Communication side cover

- FCC Part 15 (applicable in US).
- Hereby, Leica Geosystems AG, declares that the instrument with Communication side cover is in compliance with the essential requirements and other relevant provisions of Directive 1999/5/EC. The declaration of conformity may be consulted at <http://www.leica-geosystems.com/ce>.



Class 1 equipment according European Directive 1999/5/EC (R&TTE) can be placed on the market and be put into service without restrictions in any EEA Member state.

- The conformity for countries with other national regulations not covered by the FCC part 15 or European directive 1999/5/EC has to be approved prior to use and operation.

Frequency band

2402 - 2480 MHz

Output power

Bluetooth: 2.5 mW

Antenna

Type: Mono pole

Gain: +2 dBi

14.6

General Technical Data of the Instrument

Telescope

Magnification:	30 x
Free Objective aperture:	40 mm
Focusing:	1.7 m/5.6 ft to infinity
Field of view:	1°30'/1.66 gon. 2.7 m at 100 m

Compensation

Quadruple axis compensation (2-axis compensator with Hz-collimation and V-Index).

Angular accuracy ["]	Setting accuracy		Setting range	
	["]	[mgon]	[']	[gon]
1	0.5	0.2	±4	0.07
2	0.5	0.2	±4	0.07
3	1	0.3	±4	0.07
5	1.5	0.5	±4	0.07
7	2	0.7	±4	0.07

Level

Circular level sensitivity:	6'/2 mm
Electronic level resolution:	2"

Control unit

Display: 280 x 160 pixels, LCD, backlit, 8 lines with 31 characters each, heatable (temp. < -5°).

Instrument Ports

Name	Description
RS232	5 pin LEMO-0 for power, communication, data transfer. This port is located at the base of the instrument.
USB host port*	USB memory stick port for data transfer.
USB device port*	Cable connections from USB devices for communication and data transfer.
Bluetooth*	Bluetooth connections for communication and data transfer.

* Only for instruments fitted with a Communication side cover.

Instrument Dimensions

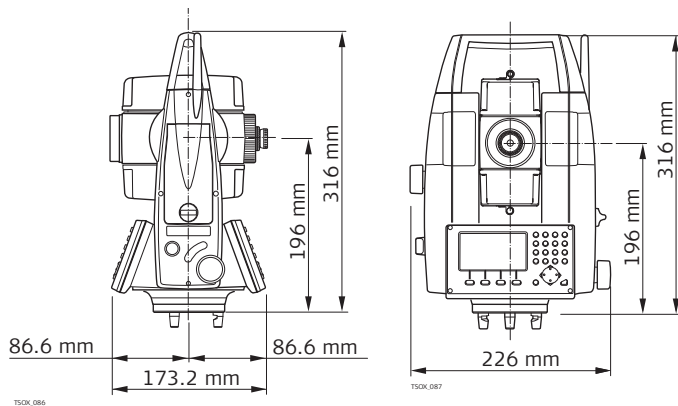

Weight

Instrument:	4.2 kg - 4.5 kg (depending on hardware configuration)
Tribrach:	760 g
Battery GEB211:	110 g
Battery GEB221:	210 g

Tilting axis height

Without tribrach:	196 mm
With tribrach (GDF111):	240 mm \pm 5 mm

Recording

Model	Memory Type	Capacity [MB]	Number of measurements
TS02	Internal memory	2	13,500
TS06 / TS09	Internal memory	10	60,000

Laser plummet

Type:	Visible red laser class 2
Location:	In standing axis of instrument
Accuracy:	Deviation from plumbline: 1.5 mm (2 sigma) at 1.5 m instrument height
Diameter of laser point:	2.5 mm at 1.5 m instrument height

Power

External supply voltage: (via serial interface)	Nominal voltage 12.8 V DC, Range 11.5 V-14 V
----------------------------------------------------	----------------------------------------------

Battery GEB211

Type:	Li-Ion
Voltage:	7.4 V
Capacity:	2.2 Ah
Operating time*:	approximately 10 hours

* Based on a single measurement every 30 s at 25°C. Operating time may be shorter if battery is not new.

Battery GEB221

Type:	Li-Ion
-------	--------

Voltage: 7.4 V
Capacity: 4.4 Ah
Operating time*: approximately 20 hours

* Based on a single measurement every 30 s at 25°C. Operating time may be shorter if battery is not new.

Environmental specifications

Temperature

Type	Operating temperature		Storage temperature	
	[°C]	[°F]	[°C]	[°F]
FlexLine instrument	-20 to +50	-4 to +122	-40 to +70	-40 to +158
Battery	-20 to +50	-4 to +122	-40 to +70	-40 to +158
USB memory stick	-40 to +85	-40 to +185	-50 to +95	-58 to +203

Protection against water, dust and sand

Type	Protection
FlexLine instrument	IP55 (IEC 60529)

Humidity

Type	Protection
FlexLine instrument	Max 95% non condensing. The effects of condensation are to be effectively counteracted by periodically drying out the instrument.

Arctic model

Operating range:



-35°C to +50°C (-31°F to +122°F)

To minimise unavoidable slowdown of display performance for the Arctic option, switch display heating on and connect the external battery. Allow for a short warm-up time.

**Electronic Guide
Light EGL**

Working range:

5 m to 150 m (15 ft to 500 ft)

Position accuracy:

5 cm at 100 m (1.97" at 330 ft)

**Automatic
corrections**

The following automatic corrections are made:

- Line of sight error
- Tilting axis error
- Earth curvature
- Standing axis tilt
- Vertical index error
- Refraction
- Compensator index error
- Circle eccentricity

14.7

Use of scale correction

Scale Correction

By entering a scale correction, reductions proportional to distance can be taken into account.

- Atmospheric correction.
 - Reduction to mean sea level.
 - Projection distortion.
-

Atmospheric correction

The distance displayed is correct if the scale correction in ppm, mm/km, which has been entered corresponds to the atmospheric conditions prevailing at the time of the measurement.

The atmospheric correction includes:

- Adjustments for air pressure
- Air temperature

For highest precision distance measurements, the atmospheric correction should be determined with:

- An accuracy of 1 ppm
 - Air temperature to 1°C
 - Air pressure to 3 mbar
-

Atmospheric corrections °C

Atmospheric corrections in ppm with temperature [°C], air pressure [mb] and height [m] at 60 % relative humidity.

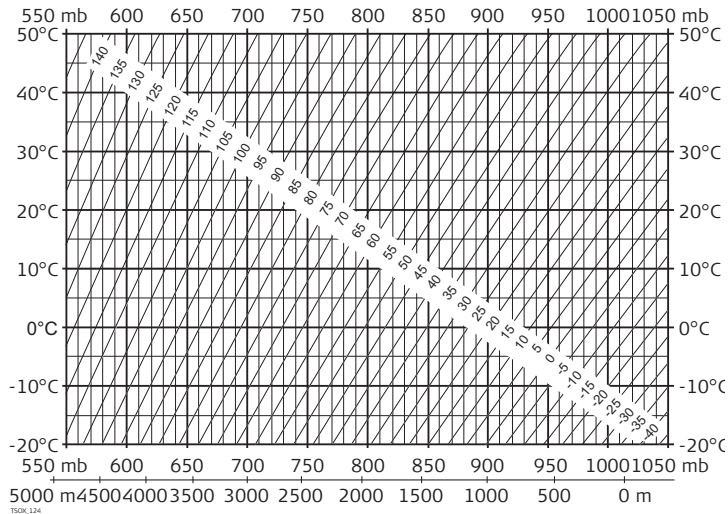

TSGK_124

Atmospheric correction °F

Atmospheric corrections in ppm with temperature [°F], air pressure [inch Hg] and height [ft] at 60 % relative humidity.

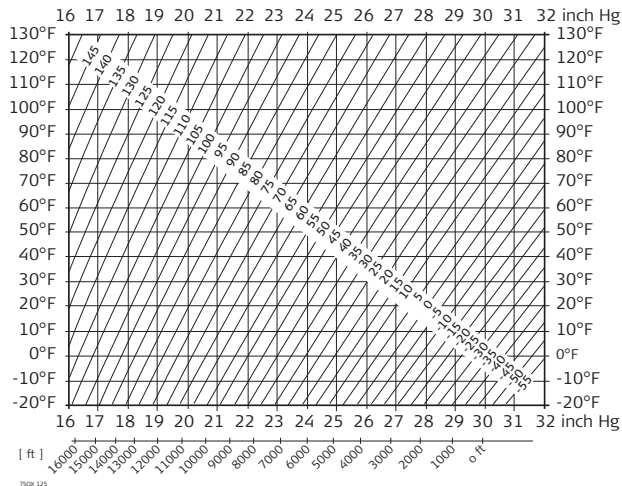



14.8

Reduction Formulas

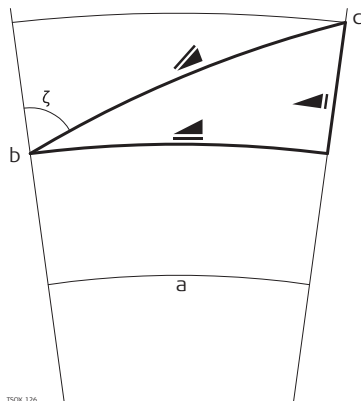
Formulas



TSOK 126

- a Mean Sea Level
- b Instrument
- c Reflector
-  Slope distance
-  Horizontal distance
-  Height difference

The instrument calculates the slope distance, horizontal distance, and height difference in accordance with the following formulas. Earth curvature ($1/R$) and mean refraction coefficient ($k = 0.13$) are automatically taken into account when calculating the horizontal distance and height difference. The calculated horizontal distance relates to the station height and not to the reflector height.

Slope distance

$$\text{▲} = D_0 \cdot (1 + \text{ppm} \cdot 10^{-6}) + \text{mm}$$

TSOK_127

- ▲ Displayed slope distance [m]
D₀ Uncorrected distance [m]
ppm Atmospheric scale correction [mm/km]
mm prism constant [mm]

Horizontal distance

$$\text{▲} = Y - A \cdot X \cdot Y$$

TSOK_128

- ▲ Horizontal distance [m]
Y ▲ * sinζ
X ▲ * cosζ
ζ = Vertical circle reading
A (1 - k/2)/R = 1.47 * 10⁻⁷ [m⁻¹]
k = 0.13 (mean refraction coefficient)
R = 6.378 * 10⁶ m (radius of the earth)

Height difference

$$\text{▲} = X + B \cdot Y^2$$

TSOK_129

- ▲ Height difference [m]
Y ▲ * sinζ
X ▲ * cosζ
ζ = Vertical circle reading
B (1 - k)/2R = 6.83 * 10⁻⁸ [m⁻¹]
k = 0.13 (mean refraction coefficient)
R = 6.378 * 10⁶ m (radius of the earth)

15 International Limited Warranty, Software License Agreement

International Limited Warranty

This product is subject to the terms and conditions set out in the International Limited Warranty which you can download from the Leica Geosystems home page at <http://www.leica-geosystems.com/internationalwarranty> or collect from your Leica Geosystems distributor.

The foregoing warranty is exclusive and is in lieu of all other warranties, terms or conditions, express or implied, either in fact or by operation of law, statutory or otherwise, including warranties, terms or conditions of merchantability, fitness for a particular purpose, satisfactory quality and non-infringement, all of which are expressly disclaimed.

Software License Agreement

This product contains software that is preinstalled on the product, or that is supplied to you on a data carrier medium, or that can be downloaded by you online pursuant to prior authorisation from Leica Geosystems. Such software is protected by copyright and other laws and its use is defined and regulated by the Leica Geosystems Software License Agreement, which covers aspects such as, but not limited to, Scope of the License, Warranty, Intellectual Property Rights, Limitation of Liability, Exclusion of other Assurances, Governing Law and Place of Jurisdiction. Please make sure, that at any time you fully comply with the terms and conditions of the Leica Geosystems Software License Agreement.

Such agreement is provided together with all products and can also be referred to and downloaded at the Leica Geosystems home page at <http://www.leica-geosystems.com/swlicense> or collected from your Leica Geosystems distributor.

You must not install or use the software unless you have read and accepted the terms and conditions of the Leica Geosystems Software License Agreement. Installation or use of the software or any part thereof, is deemed to be an acceptance of all the terms and conditions of such License Agreement. If you do not agree to all or some of the terms of such License Agreement, you may not download, install or use the software and you must return the unused software together with its accompanying documentation and the purchase receipt to the dealer from whom you purchased the product within ten (10) days of purchase to obtain a full refund of the purchase price.

16 Glossary

Instrument axis

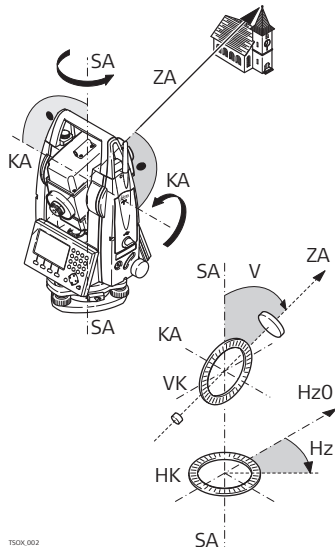

TSOX_002

ZA = Line of sight / collimation axis

Telescope axis = line from the reticle to the center of the objective.

SA = Standing axis

Vertical rotation axis of the telescope.

KA = Tilting axis

Horizontal rotation axis of the telescope. Also known as the Trunion axis.

V = Vertical angle / zenith angle

VK = Vertical circle

With coded circular division for reading the vertical angle.

H_z = Horizontal direction

HK = Horizontal circle

With coded circular division for reading the horizontal angle.

Plumb line / compensator



Direction of gravity. The compensator defines the plumb line within the instrument.

Standing axis inclination

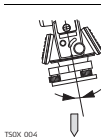

Angle between plumb line and standing axis. Standing axis tilt is not an instrument error and is not eliminated by measuring in both faces. Any possible influence it may have on the horizontal direction or vertical angle is eliminated by the dual axis compensator.

Zenith

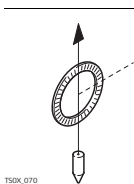

Point on the plumb line above the observer.

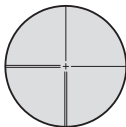
Reticle

TSDX_071

Glass plate within the telescope with reticle.

**Line-of-sight error
(horizontal
collimation)**

TSDX_005

The line-of-sight error (c) is the deviation from the perpendicular between the tilting axis and line of sight. This could be eliminated by measuring in both faces.

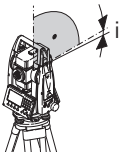
Vertical index error

TSDX_006

With a horizontal line of sight the vertical circle reading should be exactly 90° (100 gon). The deviation from this value is termed the Vertical index error (i).

Tilting axis error

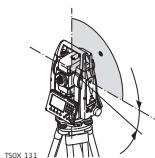

The tilting axis error is the deviation within the horizontal rotation axis, between measurements in both faces.

Explanation of displayed data

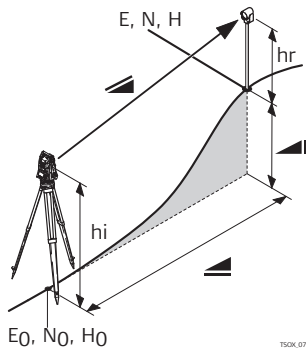

▲ Indicated meteorological corrected slope distance between instrument tilting axis and center of prism/laser dot

▲ Indicated meteorological corrected horizontal distance

▲ Height difference between station and target point

hr Reflector height above ground

hi Instrument height above ground

E_0, N_0, H_0 Easting, Northing and Height coordinates of station

E, N, H Easting, Northing and Height coordinates of target point

Appendix A Menu Tree



Menu Tree

Depending on local firmware versions the menu items may differ.



Q-Survey



Programs

- |-- Surveying
- |-- Stakeout
- |-- Free Station
- |-- Reference Element
- |-- Tie Distance
- |-- Area & Volume
- |-- Remote Height
- |-- Construction
- |-- Cogo
- |-- Road 2D
- |-- Roadworks 3D
- |-- TraversePRO
- |-- Reference Plane



Manage

- |-- Jobs
- |-- Fixpoints
- |-- Measurements
- |-- Codes
- |-- Formats
- |-- Delete Job Memory
- |-- Memory Statistics
- |-- USB-File Manager

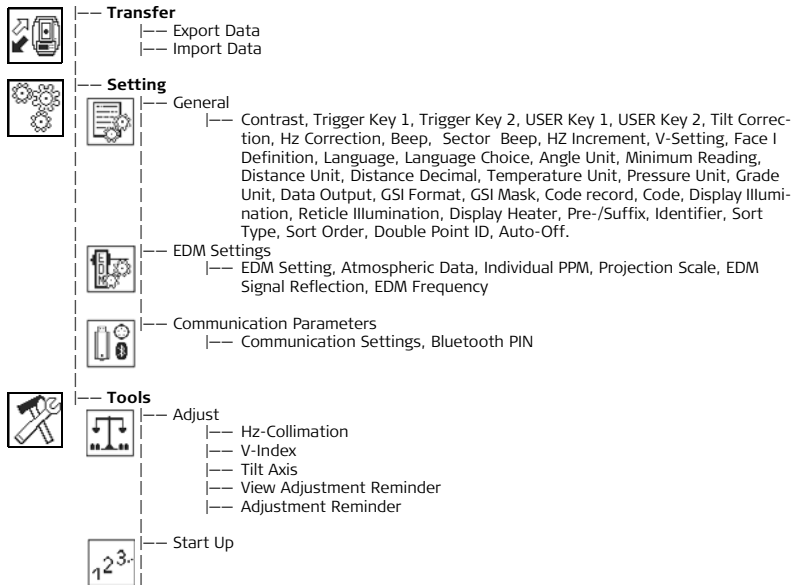

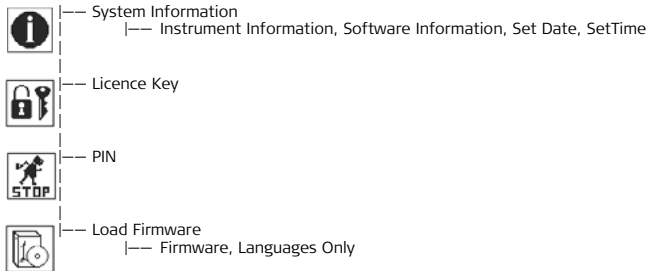

Appendix B Directory Structure

Description

On the USB memory stick, files are stored in certain directories. The following diagram is the default directory structure.

Directory Structure

-- CODES	<ul style="list-style-type: none">• Codelists (*.cls)
-- FORMATS	<ul style="list-style-type: none">• Format files (*.fmt)
-- JOB	<ul style="list-style-type: none">• GSI, DXF and LandXML files (*.*)• Logfiles created from applications
-- SYSTEM	<ul style="list-style-type: none">• Firmware files (FlexField.fw and FlexField_EDM.fw)• Language files (FlexField_Lang_xx.fw)• Licence file (*.key)• Configuration files (*.cfg)

Index

A

- Accuracy
 - Angle measurement 271
 - Non-Prism mode 275, 276
 - Prism mode 273
- Adjustment
 - Adjustment reminder 64
 - Combined adjustment 233
 - Electronic 231, 235
 - Errors, view current 63
 - Inspecting laser plummet 241
 - Line of sight 233
 - Mechanical 231
 - Of circular level on instrument 240
 - Of circular level on tribrach 240
 - Preparation 232
 - Tilt axis 237
 - Vertical index 233
- Alignments
 - Creating or uploading 181
 - Description of 173
- Angle measurement 271
- Angle unit, setting of 47, 73
- Applications
 - Area and Volume 149
 - COGO 159
 - Construction 154
 - Free Station 111
 - Reference Element 118, 136
 - Reference Plane 214
 - Remote Height 153
 - Road 2D 166
 - Roadworks 3D 171
 - Stakeout 105
 - Surveying 104
 - Tie Distance 146
 - TraversePRO 197
- Applications - Getting Started
 - Pre-settings for applications 92
 - Set accuracy limit 112
 - Set EDM 155
 - Set Job 94
 - Set Orientation 97
 - Set Station 95
 - Set Tolerances 199
- Arctic instrument 284

Area and Volume, application	149
Atmospheric data, setting of	59
Auto Start, start up sequence	64
Auto-Off, setting of	53

B

Base line	119
Battery	
Care	245
Changing of	36
Charging	35
First-time use	35
Icon	22
Labelling	270
Technical data GEB211	282
Technical data GEB221	283
Baudrate	61
Beep, setting of	44
Bluetooth	
Antenna	278
Communication parameters	61
Connection	229
Data transfer	230
Icon	23
Output power	278
PIN	60

Safety directions	267
-------------------------	-----

C

Care	244
Check & Adjust	231
Check Tie	84
Circular level, adjustment of	240
Cleaning and Drying	246
Coding	
Data management	219
Editing / Extending	88
Free coding	73
GSI coding	87
Quick code	89
Standard	87
COGO, application	159
Collimation axis	292
Communication parameters	60
Communication side cover	
Description	18
Frequency band	278
Technical data	278
Compensation	279
Compensator, icon	22
Configuration, setting of	42
Connecting Bluetooth	229

Constants, prism	57	Display illumination, setting of	51
Construction, application	154	Display, technical details of	280
Container contents	14	Distance decimal places, setting of	49
Contrast, setting of	42	Distance unit, setting of	48, 73
Coordinates, orientation with	99	Double point, setting of	52
Corrections		E	
Atmospheric	285	Edit fields, how to	26
Automatic	284	Electromagnetic compatibility EMC	266
Scale	285	Electronic adjustment	231
Cut situation, slopes	180, 194	Electronic Distance Measurement EDM	
Cylinder Offset	76	Guidelines for correct results	40
D		Icons	22
Data		Laser pointer	57
Storage	37	Non-Prism mode	274
Transfer	220	Prism (>3.5 km)	276
Data formats	224	Prism constant	57
Data management	218	Prism mode	272
Data output, setting location of	50	Prism Types	55
Databits	61	Settings	54
Date	65	Signal reflection	59
Delete job memory	219	Tracking	86
Delete last record	72	Electronic Guide Light EGL	
Dimensions, of instrument	281	Guide Light settings	57
Directory structure	299	Safety directions	262
Display heater, setting of	51	Technical data	284

Electronic level, level up instrument	32	Description of	72
Endmark	61	FNC key	19
Export data	220		
Extension, COGO application	165		
F		G	
Face, setting of	47	Glossary	292
FCC Statement	268	Grade unit, setting of	49
Fields, common	103	GSI	
File extensions	224	Coding	87
File Management	218	Output mask, setting of	50
Fill situation, slopes	181, 194	Output format, setting of	50
Firmware information	66	H	
Fixpoint data	219	Hazards of use	250
FlexField firmware	12	Height Transfer	80
FlexOffice		Hidden Point	81
Description	13	Horizontal alignment	173
Folder structure	299	Horizontal angle, setting of	45
Formats, management of	219	Hz corrections, setting of	44
Formatting		Hz increment	45
Internal memory	66	I	
USB Stick	228	Icons	22
Free coding	87	Identifier, setting location of	51
Free Station, application	111	Import data	224
Functions FNC		Individual PPM, setting of	59
Access	72		

Instrument		Language	
Components	16	Deleting	42
Configuration	42	Selection of	25
Dimensions	281	Setting of	47
Level up	32	Setting of choice	47
Ports	280	Upload language	70
Protection with PIN	68	Laser	
Settings	42	Classification	255
Setup	29	Distancer	40
Technical Data	279	Laser plummet	
Instrument information	65	Adjust intensity	34
Intended use	247	Inspect	241
Intersections, COGO application	161	Safety directions	263
Inverse and traverse, COGO application	159	Technical data	282
J		Laser pointer	
Job, management of	218	On/Off	73
K		Setting of	57
Keyboard	19	Level	279
Keys	19	Level / Plummet screen, access	72
L		Licence keys, entry of	67
Labelling	257, 260, 264, 270	Limits of use	249
		Line of sight	294
		Adjustment	233
		Lock instrument	69

M

Main menu	37
Maintenance, end date	66
Manual angle setting, orientation	98
Manual, validity of	4
Measurement data	219
Mechanical adjustment	231
Memory statistics, management of	219
Menu tree	296
Minimum reading, setting of	48

N

Navigation key	20
Non-Prism measurements	40
Non-Prism/Prism Toggle	72

O

Offsets, COGO application	163
Operating concept	12
Operating temperature	283
Operation, of instrument	29
Orientation	
Manual angle setting	98
With Coordinates	99

P

Parity	61
PIN	
Bluetooth PIN	60, 229
Instrument PIN	68
Plumb line	293
Point search	27
Points	
Multiple points with same ID	52
Ports	
Communication parameters	60
Instrument ports	280
PPM, setting of	59
Pressure unit, setting of	49
Prism	
Absolute constant	57
Icons	23
Leica constant	57
Type	55
Prism measurements	41
Projection scale, setting of	59
PUK code, use of	69
Q	
Q-CODE	89
Quadruple-axis compensation	279

Quick coding	89	Set job	94
R		Set orientation	97
Recording code, setting of	51	Set station	95
Reduction Formulas	288	Set tolerances	199
Reference Arc, application	136	Settings, configuration of	42
Reference Line, application	118	Setup	
Reference Plane, application	214	Instrument	29
Refraction coefficient	289	Tripod	29
Remote Height, application	153	Slope elements, description of	180
Remote point	154	Slope grade	191
Responsibilities	249	Slope types	191
Reticle	294	Softkeys	24
Reticle illumination, setting of	51	Software	
Road 2D, application	166	Loading	70
Road Projects, elements of	173	Software information	
Roadworks 3D, application	171	Application information	66
Rod Length	82	Firmware details	66
RS232, communication parameters	61	Stakeout, application	105
S		Standing axis	293
Safety directions	247	Start-up sequence, auto start	64
Screen	21	Stopbits	61
Search	27	Storage	245
Sector beep, setting of	44	Storage temperature	283
Serial interface, plug connections	62	Surveying, application	104
		Symbols, used in this manual	3

T

Target Offset	74
Technical data	271
Telescope	279
Temperature	
Battery	283
Instrument	283
USB stick	283
Temperature unit, setting of	49
Terminology	292
Tie Distance, application	146
Tilt and horizontal corrections	53
Tilt Axis, adjustment	237
Tilt correction, setting of	43
Tilting axis, description of	295
Time	65
Tools	
Adjust	63
Auto start	64
Licence keys	67
Load Software	70
System Information	65
Tracking, EDM	86
Transport	244

U

Traverse	
TraversePRO, application	197
With known backsight	203
Without known backsight	202
Trigger key	
Description	21
Setting of	42
Tripod	
Service	243
Setup	29
U	
Units, settings of	47
Upload languages	70
Upload licence key	67
Upload software	70
USB	
Directory Structure	299
File Manager	220
Formatting	228
Icon	23
Inserting	226
User interface	19
USER key, setting of	43

V

Vertical alignment	173
Vertical angle	
Description	292
Setting of	45
Vertical index	
Adjustment	233
Description	294
Volume, application	149

W

Weight	281
Wildcard search	28

Z

Zenith	46, 293
Zenith angle	292

Total Quality Management: Our commitment to total customer satisfaction.



Leica Geosystems AG, Heerbrugg, Switzerland, has been certified as being equipped with a quality system which meets the International Standards of Quality Management and Quality Systems (ISO standard 9001) and Environmental Management Systems (ISO standard 14001).

Ask your local Leica dealer for more information about our TQM program.

Leica Geosystems AG

Heinrich-Wild-Strasse
CH-9435 Heerbrugg
Switzerland
Phone +41 71 727 31 31

www.leica-geosystems.com

- when it has to be **right**

Leica
Geosystems