

# Dynamic Biogeochemical Models

## CHAPTER OUTLINE

<b>7.1. Introduction</b> .....	<b>175</b>
<b>7.2. Application of Biogeochemical Dynamic Models</b> .....	<b>177</b>
<b>7.3. The Streeter-Phelps River BOD/DO Model, Using STELLA</b> .....	<b>179</b>
<b>7.4. Eutrophication Models I: Simple Eutrophication Models with 2–4 State Variables</b> .....	<b>184</b>
7.4.1. Predictions of Eutrophication From Concentrations of Nutrients.....	190
<b>7.5. Eutrophication Models II: A Complex Eutrophication Model</b> .....	<b>192</b>
7.5.1. Eutrophication Models: An Overview .....	192
<b>7.6. Model of Subsurface Wetland</b> .....	<b>208</b>
7.6.1. Process Equations .....	211
7.6.2. Parameters .....	214
7.6.3. Differential Equations .....	215
7.6.4. Model Results.....	217
7.6.5. Practical Information About Forcing Functions and Parameters.....	217
7.6.6. Use of the Model for Wetland Design.....	218
<b>7.7. Global Warming Model</b> .....	<b>218</b>
<b>Problems</b> .....	<b>225</b>

## 7.1. Introduction

This chapter gives detailed examples of typical dynamic biogeochemical models and discusses the considerations that have to be made when selecting the model complexity and equations. The past 30 years have witnessed a pronounced development and application of biogeochemical models. The models are often formulated as a set of differential equations combined with some algebraic equations and a parameter list. The differential equations require the definition of an initial state.

The following biogeochemical models are included in this chapter to illustrate and demonstrate their wide applicability in ecological and environmental modelling:

1. Classical Streeter-Phelps river BOD/DO model
2. Simple eutrophication models based on up to only 2–4 state variables
3. Complex eutrophication model that has been applied to 25 case studies with modifications from case-to-case
4. Wetland model used for design and construction of wetlands for the treatment of drainage water or wastewater
5. Model for the prediction of global warming

The two eutrophication models (2 and 3) are used to show the complexity spectrum of available models. The selection of model complexity will be discussed with reference to Chapter 2, Section 2.6. Furthermore, the generality of models and their ability to develop predictions will be discussed using the eutrophication models as examples. All five of these models are discussed in detail; the reader will get a good impression of how to develop and use biogeochemical models and how to assess the advantages and disadvantages of each model. Hopefully, the reader will learn to be critical and understand the considerations involved in modelling, including the selection of balanced model complexity.

Wetland models have been very much in focus recently due to an increasing interest for these ecosystems as habitats for birds and amphibians. Wetland restoration or wetland construction is an effective method of abatement of nutrient pollution from nonpoint sources (agricultural pollution). This has increased the demand for good management models in this area. The presented wetland model has been widely applied to design and construct wetlands.

Biogeochemical models are widely used to solve a number of concrete management problems:

- Optimization of biological treatment
- Groundwater contamination
- Atmospheric acidification (see Rains model in Alcamo et al., 1990)
- Forest growth and yield (Vanclay, 1994)
- Air pollution problems (Gryning & Batchvarova, 2000)
- Agricultural production (France & Thornley, 1984)

## 7.2. Application of Biogeochemical Dynamic Models

Ecosystems are dynamic systems and biogeochemical models attempt to capture the dynamics and cycling of biochemical and geochemical compounds in the ecosystems. When models are used as an instrument in environmental management, they must account for the fate and distribution of both pollutants and of nature's own compounds. This requires the application of biogeochemical models, since they focus on the processes and transformation of various compounds in the ecosystem. As pointed out in Chapter 2, Section 2.3, the construction of dynamic models requires data, which can elucidate the dynamics of the processes included in the model. Generally, a more comprehensive database is required to build a dynamic model than a static model. Therefore, in a data-poor situation, it might be better to draw up an average situation under different circumstances using a static model than to construct an unreliable dynamic model, which contains uncertainty in the most crucial parameters

The first biogeochemical model constructed was the Streeter-Phelps BOD/DO model in 1925. It has been used numerous times as an illustration of biogeochemical models and of the practical use of ecological models in environmental management (Jørgensen, 2009). As a seminal example, it clearly illustrates the concepts of the biogeochemical models, and is presented in detail in the next section. The Streeter-Phelps model consists, opposite from most dynamic models, of only one differential equation that can be solved analytically. Here we use STELLA to simulate and demonstrate the applicability of the model solution.

Hydrodynamic models can be considered biogeochemical models, since they describe the fate and distribution of the important compound water in ecosystems. Output from hydrodynamic models is often used as forcing function in ecological models. If only the hydrology is modelled, then hydrodynamic models are not ecological models, as they do not account for biological processes. However, they are often used in conjunction with ecological models, as the distribution of chemical compounds and living organisms is dependent on the hydrodynamics. During the 1990s, 3-D hydrodynamic models were applied more frequently, and

today, well-developed ecological models such as eutrophication models are coupled with 3-D hydrodynamic models. It is important to emphasize that coupling simple ecological models with 3-D models is not feasible because the standard deviations of a validation and the reliability of the predications are determined by the weakest link in the chain of calculations. Hydrodynamic models are, however, beyond the scope of this book and will not be discussed further.

The experience gained by developing many biogeochemical models over time has shown that:

1. A good knowledge of the ecosystem is required to capture the essential features, which should be reflected in the model.
2. The scope of the model determines the complexity, which again determines the quality and quantity of the data needed for calibration and validation.
3. If good data are not available, then it is better to go for a somewhat oversimplified model instead of one that is too complex.
4. Simple models are more general than complex models. If the database allows development of a more complex model, then it will contain some processes and components specific for the considered ecosystem.

During the 1970s and the early 1980s, a great deal of experience was gained in modelling many different types of ecosystems and many different aspects, including a number of problems relating to environmental degradation. The modellers also learned which modifications were necessary when a model was applied for the same situation but on a different ecosystem from which it was originally developed. It was seen that the same model could not be applied to another ecosystem without some changes, unless the model was very simple. More and more models became well calibrated and validated. The models could often be used as a practical management tool, but in most cases it was necessary to combine the use of the model with a good knowledge of general environmental issues. Also, in cases when the model could not be applied to set up accurate predictions, it was useful for the manager to qualitatively understand the ecosystem for various management strategies. Scientists who applied models found that they were very useful to indicate research priorities and also to capture the system features of ecosystems.

### 7.3. The Streeter-Phelps River BOD/DO Model, Using STELLA

For rivers and streams, the main environmental problem is low oxygen concentration that occurs in response to the discharge of organic matter. The questions posed for the model are:

1. What is the concentration of organic matter, expressed frequently as  $BOD_5$  mg/L, as a function of time?  $BOD_5$  mg/L is the amount of oxygen that the decomposition of the organic matter will consume during a period of 5 days.
2. What is the oxygen concentration as a function of the distance from the discharge point of organic matter?
3. What is the minimum oxygen concentration?

A river model is presented in that next section that is able to answer these questions. It is developed using the STELLA software, which was introduced in Chapter 2, Section 2.3 and 5. After presentation of the classical Streeter-Phelps model, a discussion about which processes would probably be beneficial to include if the model is to be expanded to include more components and interactions will be presented.

Organic matter decomposition can be approximated by a first-order reaction. If  $L$  is the concentration of organic matter (mg/L) and  $k_1$  is the rate coefficient for the decomposition, then the following differential equation is valid:

$$dL/dt = -k_1L \quad (7.1)$$

Equation (7.1) has the following analytical solution:

$$L_t = L_0 e^{-k_1 t} \quad (7.2)$$

where  $L_t$  is the concentration at time  $t$  and  $L_0$  is the initial concentration.

$L$  is most often expressed as  $BOD_5$  mg/L oxygen consumption during a period of 5 days. If it is expressed as mg/L (average) organic matter or detritus, then the concentration, according to the processes, has to be multiplied by 1.39. In other words, 1 g of detritus or organic matter requires an average of 1.39 g oxygen to be decomposed as much as it is possible during a period of 5 days (which is nearly 100%)

Nitrification of ammonium also causes oxygen depletion and should be included in this process. If the ammonium concentration is denoted

NC (mg N/L in the form of ammonium) and it is presumed that nitrification follows a first-order reaction, then the following differential equation is valid:

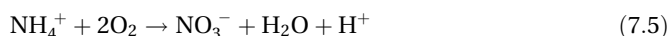
$$dNC/dt = -k_N NC \quad (7.3)$$

where  $k_N$  is the rate coefficient for the nitrification. Equation (7.3) has the following solution:

$$NC_t = NC_0 e^{-k_N t} \quad (7.4)$$

where  $NC_t$  is the concentration at time  $t$  and  $NC_0$  the initial concentration.

Notice that NC is the concentration in mg ammonium-N/L and the corresponding oxygen consumption is found from the chemical equation for the nitrification:



It means that 1 g of ammonium-N requires  $2 \cdot 32 / 14 = 4.6$  g of oxygen, which will be included in the model when the nitrification is “translated” to oxygen depletion. The factor is 4.3 not 4.6, due to the bacterial assimilation of ammonium by the nitrifying microorganisms.

Instead of a first-order expression for Eq. (2.5), one could apply a Michaelis-Menten equation (Jørgensen & Bendoricchio, 2001). According to the Michaelis-Menten expression used in eutrophication models (see Chapter 2), Eq. (7.1) could be multiplied by:

$$[Ox]/(k_{mo} + [Ox]) \quad (7.6)$$

to account for the influence of oxygen as a limiting factor of the decomposition rate. Similarly, Eq. (7.3) could be multiplied by:

$$\min ([NC]/(k_{ma} + [NC]), [Ox]/(k_{ao} + [Ox])) \quad (7.7)$$

to account for the influence of both ammonium and oxygen as possible limiting factors of the decomposition. When the model has to be erected, the Michaelis-Menten expressions will be applied, but it is also possible to get reasonably good results using the first-order expressions, which have the advantage that they can easily be solved analytically.

The decomposition of organic matter and nitrification are temperature dependent. A simple Arrhenius expression may be applied:

$$\begin{aligned} &\text{The rate coefficient at temperature (Celsius) } T \\ &= \text{rate coefficient at 20 degree Celsius} * K^{(T-20)} \end{aligned} \quad (7.8)$$

K is, with good approximation, 1.05 for organic matter decomposition while nitrification is more sensitive to temperature changes; therefore, K is 1.07–1.08 for this process (Jørgensen, 2000).

Typical values for the rate coefficients and the initial concentrations for various sources of organic matter and ammonium are shown in Table 7.1.

If the oxygen concentration is below the saturation concentration, that is, the water is in equilibrium with the atmosphere, then reaeration from the atmosphere takes place. The equilibrium concentration can be found by Henry's Law. The saturation concentration is dependent on the water temperature and salinity. In Appendix 1, Table 1, the equilibrium concentration of oxygen can be found as a function of the temperature and salinity.

Aeration is proportional to the difference between the oxygen concentration at saturation,  $O_{x_{sat}}$ , and the actual oxygen concentration,  $[Ox]$ . The driving force for the aeration is this difference. It is expressed by:

$$\text{Reaeration} = d[Ox]/dt = K_a(O_{x_{sat}} - [Ox]) \quad (7.9)$$

where  $K_a$  is the reaeration coefficient (1/24h).

$K_a$  is dependent on the water temperature and flow rate. The aeration is also proportional to the surface area relatively to the volume; it is inversely proportional to the water depth. There are several hundred empirical equations that can be used to estimate the reaeration or the reaeration coefficient. One equation often applied is:

$$K_a = 2.26 * v * \exp(0.024 * (T - 20)/d), \quad (7.10)$$

**Table 7.1** Characteristic Values for  $k_1$ ,  $k_N$  (1/24h) and Initial Concentrations (mg/L) for Various Sources to Oxygen Depletion in Streams and Rivers

Source	$k_1$	$k_N$	$L_0$	$NC_o$
Municipal waste water	0.35–0.40	0.15–0.25	180–300	20–45
Mechanically treated waste water	0.32–0.36	0.10–0.15	100–200	18–35
Biologically treated waste water	0.10–0.25	0.05–0.20	10–40	15–32
Potable water	0.05–0.10	0.03–0.06	0–2	0–1
River water (average)	0.05–0.15	0.04–0.10	1–4	0–2
Agricultural drainage water	0.08–0.20	0.04–0.12	5–25	0–10
Waste water, food industry	0.4–0.5	0.1–0.25	200–5000	20–200

where  $v$  is the water flow rate in m/s,  $T$  is the temperature in Celsius, and  $d$  is the depth of the stream or river in m.

The oxygen concentration is determined by the difference between the consumption and the reaeration. If we only consider decomposition of organic matter and nitrification, then the oxygen concentration is determined by the following differential equation:

$$d[\text{Ox}]/dt = k_a(\text{Ox}_{\text{sat}} - [\text{Ox}]) - k_1L - k_N\text{NC} \quad (7.11)$$

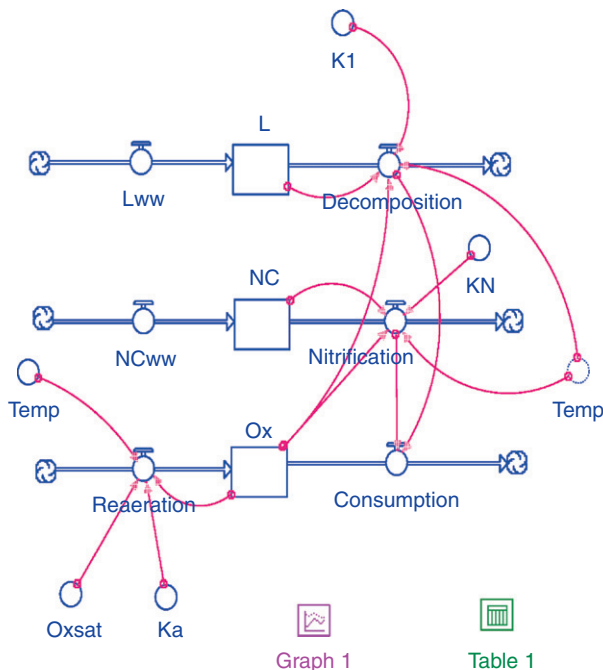
The solution of the differential equations for  $L$  and  $\text{NC}$  can be used in this differential equation to yield the following expression for the solution of  $[\text{Ox}]$  as function of time:

$$d[\text{Ox}]/dt = k_a(\text{Ox}_{\text{sat}} - [\text{Ox}]) - k_1L_0 e^{-k_1t} - k_N\text{NC}_0 e^{-k_Nt} \quad (7.12)$$

This equation can be solved analytically, but we will use STELLA to determine  $[\text{Ox}]$ ,  $L$ , and  $\text{NC}$  as a function of time in accordance with the previous Michaelis-Menten equation. It is possible to add many more processes to the model, such as primary production by phytoplankton and macrophytes producing oxygen, denitrification consuming organic matter as a carbon source, the presence of organic matter with different biodegradability, changed reaeration at turbulent flow, and so on. As always, when we develop models, the problem, the available data, and the system processes should determine the model complexity.

A diagram of the STELLA model (Figure 7.1) shows three state variables: (1) organic matter,  $L$ ; (2) ammonium-nitrogen,  $\text{NC}$ ; and (3) oxygen,  $\text{Ox}$ . These are each covered by three different connected submodels. The oxygen is consumed by the decomposition of organic matter and nitrification. The oxygen concentration influences the decomposition rate and nitrification as presented in Eqs. (7.6) and (7.7). Time is considered the independent variable, but it could also be the distance from the discharge of wastewater. For example, if the water flow rate is 1 m/s, then the time in days will correspond to  $1 \cdot 3600 \cdot 24 \text{ m} = 86400 \text{ m}$ . The model has a constant discharge, which can be considered to be agricultural drainage water along the stream shoreline. The point discharge of wastewater takes place at time 0 corresponding to the initial value of  $L$  and  $\text{NC}$ . The dilution has to be considered when the initial values are calculated. If  $1000 \text{ m}^3$  waste water/h with 30 mg/L of  $\text{BOD}_5$  and 13 mg/L ammonium-N is discharged to a river with  $5000 \text{ m}^3$  of water flow/h, then the dilution factor is 6. If the river water

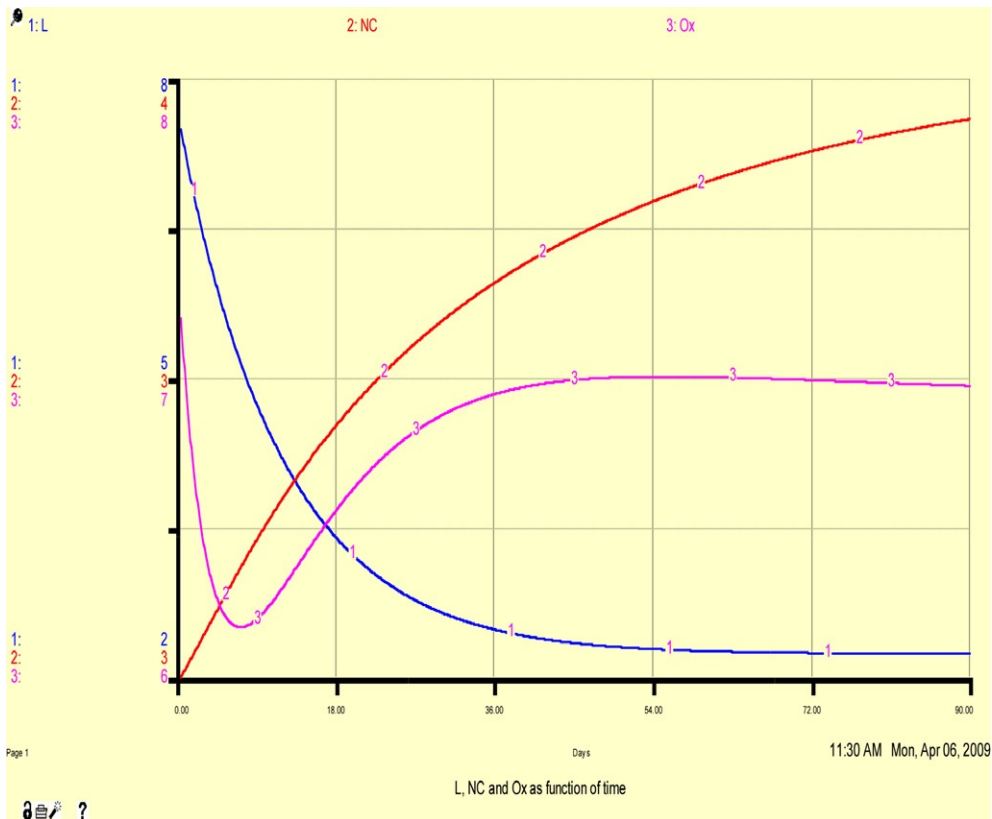




**FIGURE 7.1** Conceptual diagram of the presented river model by application of the STELLA software.

has 3 mg BOD<sub>5</sub>/L and 1 mg ammonium-N/L, then the mixture of river water and wastewater will have  $(5 \cdot 3 + 30 \cdot 1) / 6 = 7.5$  mg BOD<sub>5</sub>/L and  $(1 \cdot 5 + 13 \cdot 1) / 6 = 3$  mg ammonium-N/L, which are applied as the initial concentrations. The model should be able to give information about how these concentrations change over time. The concentration of oxygen in treated wastewater will almost always be close to 0 mg/L. If the river water has 8.6 mg/L oxygen, then the mixture of wastewater and river water will have an oxygen concentration of about 7.2 mg/L corresponding to a dilution of the wastewater by a factor 6.

The result of running the model 90 days is shown in [Figure 7.2](#), and the equations are presented in [Table 7.3](#). Notice the form of the differential equation applied in STELLA. Time can be translated to distance from the discharge point by the flow rate. If the cross-sectional area is 50m<sup>3</sup>, then the water flow of 10,000 m<sup>3</sup>/h corresponds to 200 m/h. Twenty-four hours therefore corresponds to 4800 m and 90 days to 432 km. The minimum oxygen concentration occurs after 8 days or 38.2 km. [Table 7.2](#) charts the model results in table form for every 5 days.



**FIGURE 7.2** The result of using the following initial values: for  $BOD_5$ , 7.5 mg/L; for ammonium-N, 3 mg/L; and for oxygen, 7.2 mg/L.

## 7.4. Eutrophication Models I: Simple Eutrophication Models with 2–4 State Variables

Eutrophication is the main cause of environmental degradation in lakes and reservoirs. It results from a nutrient concentration that is too high. The core questions for this model are:

1. What is the concentration of the limiting nutrient (which is often phosphorus)?
2. What is the primary production?
3. What are the transparency and the chlorophyll concentration when the eutrophication is at maximum?

**Table 7.2** Model Results

Day	BOD <sub>5</sub>	NC	Oxygen	Ox consumption	Decomp.	Nitrification
.0	7.50	3.00	7.20	1.01	0.67	0.08
5.0	5.64	3.11	6.21	0.83	0.49	0.08
10.0	4.47	3.21	6.24	0.74	0.39	0.08
15.0	3.70	3.30	6.45	0.69	0.32	0.08
20.0	3.19	3.37	6.64	0.66	0.28	0.09
25.0	2.86	3.43	6.78	0.64	0.25	0.09
30.0	2.64	3.48	6.88	0.63	0.24	0.09
35.0	2.50	3.52	6.94	0.62	0.22	0.09
40.0	2.40	3.56	6.98	0.62	0.21	0.09
45.0	2.34	3.59	7.00	0.61	0.21	0.09
50.0	2.30	3.62	7.00	0.61	0.21	0.09
55.0	2.28	3.64	7.01	0.61	0.20	0.10
60.0	2.26	3.66	7.01	0.62	0.20	0.10
65.0	2.25	3.68	7.00	0.62	0.20	0.10
70.0	2.24	3.70	7.00	0.62	0.20	0.10
75.0	2.24	3.71	6.99	0.62	0.20	0.10
80.0	2.24	3.73	6.99	0.62	0.20	0.10
85.0	2.24	3.74	6.98	0.62	0.20	0.10
Final	2.24	3.75	6.98			

Notes: Concentrations (BOD<sub>5</sub> or L, NC, or ammonium-N and oxygen) are all in mg/L and process rates are in mg/L per 24h

From a thermodynamic view, a lake can be considered an open system, which exchanges material (wastewater, evaporation, precipitation) and energy (evaporation, radiation) with the environment. However, in some lakes (e.g., the Great Lakes) the material input per year does not change the concentration measurably. In such cases, the system can be considered nearly closed, which means that it exchanges energy but not material with the environment.

The flow of energy through the lake system leads to at least one cycle of material in the system (provided that the system is at a steady state,

**Table 7.3** Model Equations (STELLA Format)

---

```

L(t) = L(t - dt) + (Lww - Decomposition) * dt
INIT L = 7.5
INFLOWS:
Lww = 0.2
OUTFLOWS:
Decomposition = (L*K1*Ox*1.05^(20-Temp)/(Ox+2.5))
NC(t) = NC(t - dt) + (NCww - Nitrification) * dt
INIT NC = 3
INFLOWS:
NCww = 0.1
OUTFLOWS:
Nitrification = NC*KN*MIN(Ox/(Ox+3), NC/(NC+1))*1.075^(
(Temp-20))
Ox(t) = Ox(t - dt) + (Reaeration - Consumption) * dt
INIT Ox = 7.2
INFLOWS:
Reaeration = Ka*(Oxsat-Ox)*exp(0.024*(Temp-20))
OUTFLOWS:
Consumption = Decomposition+4.3*Nitrification
K1 = 0.1
Ka = 0.226
KN = 0.05
Oxsat = 10
Temp = 16

```

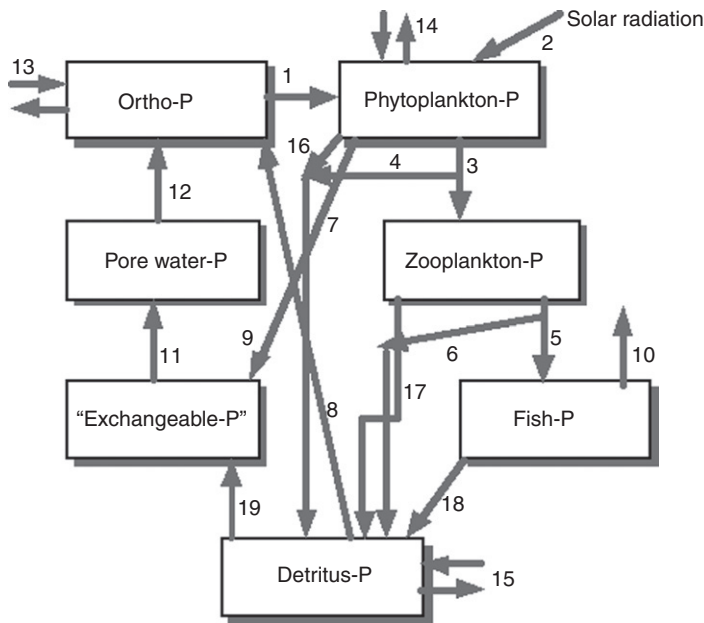
---

see Morowitz, 1968). As illustrated in Figures 2.1 and 7.3, important elements participate in cycles that control eutrophication.

The word eutrophy is generally known as “nutrient rich.” In 1919, Nauman introduced the concepts of oligotrophy and eutrophy, distinguishing between oligotrophic lakes containing little planktonic algae and eutrophic lakes containing an abundance of phytoplankton.

The eutrophication of lakes all over the world has increased rapidly during the last decades due to increased human population growth and the consequent increase in the application of synthetic fertilizers and urbanization (Vitousek et al., 1997; Jørgensen et al., 2004). The production of fertilizers has grown exponentially in this century and the concentration of phosphorus in many lakes reflects this.

The word eutrophication is used increasingly to define an artificial addition of nutrients, mainly nitrogen and phosphorus, to waters. Eutrophication is generally considered to be undesirable, but this is not always true.



**FIGURE 7.3** The phosphorus cycle. The processes are: (1) uptake of phosphorus by algae; (2) photosynthesis; (3) grazing with loss of undigested matter; (4), (5) predation with loss of undigested material; (6), (7), and (9) settling of phytoplankton; (8) mineralization; (10) fishery; (11) mineralization of phosphorous organic compounds in the sediment; (12) diffusion of pore water P; (13), (14), and (15) inputs/outputs; (16), (17), and (18) mortalities; and (19) settling of detritus.

The green color of eutrophied lakes makes swimming and boating less safe and pleasant due to the increased turbidity. From an aesthetic point of view, the chlorophyll concentration should not exceed  $100 \text{ mg m}^{-3}$ . However, the most critical effect from an ecological point of view is the reduced oxygen content of the hypolimnion caused by the decomposition of dead algae. Eutrophic lakes sometimes show a high oxygen concentration at the surface during the summer, but a low concentration of oxygen during the fall in the hypolimnion that is lethal to fish.

About 16–20 chemical elements are necessary for the growth of freshwater plants; [Table 7.4](#) lists the relative quantities of essential elements in plant tissue. The present concern about eutrophication relates to the rapidly increasing amount of phosphorus and nitrogen, which are naturally present at relatively low concentrations. Of the two, phosphorus is considered the major cause of eutrophication in lakes, because it was formerly the growth-limiting factor for algae in the majority of lakes. But as mentioned previously, its use has increased tremendously during the last decades.

Nitrogen is a limiting factor in a number of East African lakes as a result of soil nitrogen depletion by intensive erosion. However, today nitrogen

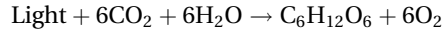
**Table 7.4** Average Freshwater Plant Elementary Composition on a Wet Weight Basis

Element	Plant content%
Oxygen	80.5
Hydrogen	9.7
Carbon	6.5
Silicon	1.3
Nitrogen	0.7
Calcium	0.4
Potassium	0.3
Phosphorus	0.08
Magnesium	0.07
Sulfur	0.06
Chlorine	0.06
Sodium	0.04
Iron	0.02
Boron	0.001
Manganese	0.0007
Zinc	0.0003
Copper	0.0001
Molybdenum	0.00005
Cobalt	0.000002

may become limiting in lakes as a result of the tremendous increase in the phosphorus concentration caused by discharge of wastewater, which contains relatively more phosphorus than nitrogen. While algae use 4 to 10 times more nitrogen than phosphorus, wastewater generally contains only 3 times as much nitrogen as phosphorus in lakes and a considerable amount of nitrogen is lost by denitrification (nitrate $\rightarrow$ N<sub>2</sub>).

The growth of phytoplankton is the key process of eutrophication, and it is important to understand the interacting processes that regulate growth. Primary production has been measured in great detail in a

number of lakes. This process represents the synthesis of organic matter and the overall process can be summarized as follows:



The composition of phytoplankton is not constant (note that [Table 7.4](#) gives only an average concentration), but reflects the concentration of the water. If the phosphorus concentration is high, then the phytoplankton will take up relatively more phosphorus — this is called luxury uptake.

As seen in [Table 7.4](#), phytoplankton consists mainly of carbon, oxygen, hydrogen, nitrogen, and phosphorus: without these elements, no algal growth takes place. This leads to the concept of limiting the nutrients mentioned earlier in Section 2.3, which is known as the law of the minimum developed by Liebig (1840). This states that the yield of any organism is determined by the substance that in relation to the needs of the organism is least abundant in the environment (Hutchinson, 1970, 1978). However, the concept has been considerably misused due to oversimplification. First of all, growth might be limited by more than one nutrient. The composition is not constant; it varies with the composition of the environment. Furthermore, growth is not at its maximum rate until the nutrients are used, and is then stopped. But the growth rate slows down when the nutrients become depleted. Another side of the problem is the consideration of the nutrient sources. It is important to set up mass balances for the most essential nutrients.

The sequences of events leading to eutrophication have often been described as follows. Oligotrophic waters will have a ratio of N:P greater than or equal to 10, which means that phosphorus is less abundant than nitrogen for the needs of phytoplankton. If sewage is discharged into the lake, then the ratio will decrease, since the N:P ratio for municipal wastewater is 3:1; consequently, nitrogen will be less abundant than phosphorus relative to the needs of phytoplankton. In this situation, however, the best remedy for the excessive growth of algae is not the removal of nitrogen from the sewage because the mass balance might then show that nitrogen-fixing algae will release an uncontrollable input of nitrogen into the lake. It is necessary to set up mass balances for each of the nutrients as these will often reveal that the input of nitrogen from nitrogen-fixing blue-green algae, precipitation, and tributaries contribute too much to the mass balance for the removal of nitrogen from the

sewage to have any effect. On the other hand, the mass balance may reveal that the phosphorus input (often more than 95%) comes mainly from sewage, which means that it is better management to remove phosphorus from the sewage than nitrogen. Thus, in environmental management it is not always important which nutrient is the most limiting, but which nutrient can most easily be made to limit algal growth.

#### 7.4.1. Predictions of Eutrophication From Concentrations of Nutrients

Dillon and Rigler (1974) developed a relationship for estimating the average summer chlorophyll a concentration (chl.a) with the N:P ratio of the water  $>12$ :

$$\log_{10}(\text{chl.a}) = 1.45 \log_{10}[(\text{P}) \cdot 1000] - 1.14 \quad (7.13)$$

For the case where the N:P ratio is  $<4$  the following equation, based upon eight case studies was evolved:

$$\log_{10}(\text{chl.a}) = 1.4 \log_{10}[(\text{N}) \cdot 1000] - 1.9 \quad (7.14)$$

(N) and (P) are expressed as mg/L while (chl.a) is found in  $\text{mg/L}^{-1}$ . If the N:P ratio is between 4 and 12, the smallest value of (chl.a) found on the basis of the two equations is recommended.

Many correlations between phosphorus concentrations and chlorophyll concentrations have been developed. Dillon and Kirchner (1975) set up a relationship between the Secchi disc transparency, SE, and phosphorus concentration. Kristensen et al. (1990) developed eight different equations that related the total phosphorus concentration ( $P_{\text{lake}}$ ) with the average transparency depth ( $z_{\text{eu}}$ ). The influence of the mean depth,  $z$ , is included in three of the equations (see [Table 7.5](#)).

The simple model presented earlier will never be as good a predictive tool as a model based on more accurate data and considering more processes. However, the semiquantitative estimations, which can be obtained by use of the simple model we have presented, are better than none at all, and in a data-poor situation it may be the only model the data can support. Furthermore, it is often an advantage to use simple models to find first estimations before a more advanced model is developed. A model with the state variables PS, NS, P<sub>sed</sub>, and N<sub>sed</sub>, and the previously mentioned regression equations is available as a simple



**Table 7.5** Relations Between Average Transparency Depth,  $z_{eu}$ , Phosphorus Concentration,  $P_{lake}$  and Mean Depth,  $z$ 

Number	Equation
1	$z_{eu} = 0.44 (+/-0.038) P - 0.54(+/-0.031)$
2	$z_{eu} = 0.36(+/-0.029) P - 0.29(+/-0.028)z + 0.51(+/-0.042)$
3	$z_{eu} = 0.39(+/-0.038) P - 0.58(+/-0.034)$
4	$z_{eu} = 0.34(+/-0.028) P - 0.29(+/-0.028)z + 0.55(+/-0.040)$
5	$z_{eu} = 0.52 (+/-0.042) P - 0.48(+/-0.031)$
6	$z_{eu} = 0.43 (+/-0.026) P - 0.20(+/-0.022)z + 0.55(+/-0.030)$
7	$z_{eu} = 0.40 (+/-0.055) P - 0.69(+/-0.064)$
8	$z_{eu} = 0.34 (+/-0.0424) P - 0.60(+/-0.041)$

After Kristensen et al., 1990.

one-layer model in the UNEP-software Pamolare. It is relatively quick and easy to use this simple model, and it is often recommended that it be used first as a modelling approach to gain insight into the most crucial processes that determine the eutrophication, before a more complex model is developed.

The differential equations for the model are:

$$dPS/dt = Q * (Pin - PS)/V - sr * PS/D + rr * Psed * AL/D \quad (7.15a)$$

$$dPsed/dt = k * sr * PS * D/AL - rr * Psed \quad (7.16a)$$

$$dNS/dt = Q * (Nin - NS)/V - sr * NS/D + rr * Nsed * AL/D \quad (7.15b)$$

$$dNsed/dt = k' * sr * NS * D/AL - rr * Nsed \quad (7.16b)$$

$Q$  is the flow rate to and from the lake. It is presumed that precipitation and evaporation are equal and that the inflows and outflows are in balance.

$PS$  is the total concentration of phosphorus in the water, including all forms (soluble phosphorus, detritus-phosphorus, and phytoplankton phosphorus).

$NS$  is the total concentration of nitrogen in the water, including all forms (soluble inorganic nitrogen [ammonium, nitrate, and nitrite], soluble organic nitrogen, detritus-nitrogen and phytoplankton nitrogen).

$Pin$  is the total phosphorus concentration in the inflowing water and  $Nin$  is the total nitrogen concentration in the inflowing water;  $sr$  is the

settling rate that could be in units of m/year based on the total amount of phosphorus and nitrogen. If it is estimated that phytoplankton and detritus in average is for instance 20% per year of total phosphorus and nitrogen, then the settling rate should be calculated as settling in  $(\text{m}/24 \text{ h}) * 365 / 5$ .

AL is the active layer of sediment, D is the water depth, and rr and rr' are the release rate of phosphorus and nitrogen, respectively. They are parameters that usually are determined by model calibration.

Notice that when sediment phosphorus and sediment nitrogen are released, the sediment nutrients are diluted by the factor AL/D, and when the settled nutrients are transferred from the water column to the sediment, the concentration becomes D/AL times higher in the sediment than in the water column.

k is the fraction of exchangeable phosphorus to total phosphorus for the settled material. A part of the settled phosphorus is bound in the sediment and cannot be released again. k accounts for exchangeable phosphorus only. If, for instance, 25% of the phosphorus is bound in the sediment, then k is 0.75.

k' is the exchangeable nitrogen to total nitrogen. Usually k' is higher than k because phosphorus compounds can be bound to a higher extent than nitrogen in the sediment by formation of calcium-hydroxo-phosphate or iron (III) phosphate.

This model has been successfully applied to Lake Washington, which is close to Seattle. The model was able to approximately predict the development of the observed phosphorus concentration (for further details see the Pamolare Software, developed by United Nations Environmental Program—International Environmental Technology Center (UNEP-IETC)).

## 7.5. Eutrophication Models II: A Complex Eutrophication Model

### 7.5.1. Eutrophication Models: An Overview

As expected, due to the importance of eutrophication in environmental management, numerous eutrophication models covering a wide spectrum of complexity have been developed. As for other ecological models, the right complexity of the model is dependent on the available data and the ecosystem. [Table 7.6](#) reviews various eutrophication models.

**Table 7.6** Various Eutrophication Models

Model Name	Number of St. Var. per Layer or Segment	Nutrients	Segments	Dimension 2L, 1D	CS or NC*	C and/or V**	Number of Case Studies
Vollenweider	1	P(N)	1	1L	CS	C+V	many
Imboden	2	P	1	2L, 1D	CS	C+V	3
O'Melia	2	P	1	1D	CS	C	1
Larsen	3	P	1	1L	CS	C	1
Lorenzen	2	P	1	1L	CS	C+V	1
Thomann 1	8	P,N,C	1	2L	CS	C+V	1
Thomann 2	10	P,N,C	1	2L	CS	C	1
Thomann 3	15	P,N,C	67	2L	CS	–	1
Chen&Orlob	15	P,N,C	sev.	2L	CS	C	min. 2
Patten	33	P,N,C	1	1L	CS	C	1
Di Toro	7	P,N	7	1L	CS	C+V	1
Biermann	14	P,N,Si	1	1L	NC	C	1
Canale	25	P,N,Si	1	2L	CS	C	1
Jørgensen	17–20	P,N,C,	1	1-2L	NC	C+V	26
Cleaner	40	P,N,C,Si	sev. sev.	L	CS	C	many
Nyholm, Lavsoe	7	P,N	1–3	1-2L	NC	C+V	25
Aster/Melodia	10	P,N,Si	1	2L	CS	C+V	1
Baikal	>16	P,N	10	3L	CS	C+V	1
Chemsee	>14	P,N,C,S	1	profile	CS	C+V	many
Minlake	9	P,N	1	1	CS	C+V	>10
Salmo	17	P,N	1	2L	CS	C+V	16

Notes:

\*CS, constant stoichiometric; NC, independent nutrient cycle.

\*\*C, calibrated; V, validated.

Table 7.6 indicates the characteristic features of the models, the number of case studies to which it has been applied (with some modification from case study-to-case study, as site-specific properties should be reflected in the selected modification, unless the model is very simple), and whether the model has been calibrated and validated.

It is not possible to review all complex models in detail. Therefore, one model among the more complex models has been selected and presented in detail here. Eutrophication models are illustrative examples because they demonstrate quite clearly the ideas behind biogeochemical models. The calibration and validation of the selected model and its use to develop scenarios will be discussed. The results demonstrate what can be achieved by using ecological models, provided that sufficient effort is expended to obtain good data and good ecological background knowledge about the modelled ecosystem.

The conceptual diagrams of the nutrient cycles are presented in Figures 2.1 and 7.3. This model was developed for Lake Glumsø — a case study that has the following advantages:

1. The lake is shallow (mean depth 1.8 m) and no formation of a thermocline takes place. The case study is thus relatively simple.
2. The lake is small (volume 420,000 m<sup>3</sup>) and well mixed, which implies it is unnecessary for a model to consider hydrodynamics and it can instead focus on ecological processes.
3. Retention time is short (<6 months), which means that any change due to a management action can be observed fairly rapidly.
4. A radical change in nutrient input occurred in April 1981, and subsequent water quality changes were observed (Jørgensen, 1986).
5. It is unique, in that a prediction of the water quality was published before any changes actually took place (Jørgensen et al. 1978). It has since been possible to validate this prediction.
6. The lake was intensely studied from 1973 to 1984. The model is therefore based on comprehensive data.

The success of this model has led to its application to at least 25 other case studies — of course with the necessary modifications.

The Lake Glumsø model is probably one of the most well-examined eutrophication models. The results represent what is obtainable in

relation to validation under almost unchanged loading, to accuracy in predictions, and to general applicability. Therefore, these results are emphasized in the following presentation.

The ecology of Lake Glumsø was investigated before the model was developed (Jørgensen et al. 1973). The phases in modelling development presented in Chapter 2 were followed very carefully to obtain a model with the predictive power needed for use as a management instrument.

Figures 2.1 and 7.3 are the conceptual diagrams of the N- and P-flows of the model. Many of the equations can be found in other eutrophication models. It seems of little value to present all of the model's equations, and the following sections are devoted to the most characteristic features of the model to illustrate typical modelling considerations. They are:

1. Independent cycling of N, P, and C, which is a result of the two-step process description of phytoplankton growth.
2. A more detailed description of the water-sediment interactions is extremely important for many lakes where a significant amount of the nutrient is stored in the sediment.
3. The equation applied for the description of the grazing of phytoplankton by zooplankton, which takes into account a threshold concentration of phytoplankton and a carrying capacity of the lake.

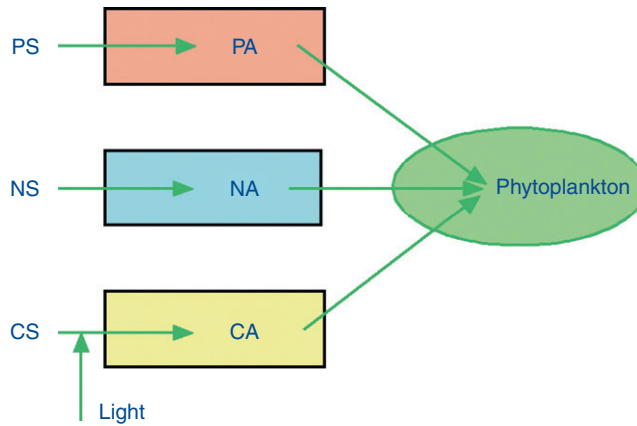
The two steps describing the phytoplankton growth are (see also Figure 7.4):

1. Uptake of nutrients according to Monod's kinetics
2. Growth determined by the internal substrate concentration

In other words, independent nutrient cycles of phosphorus, nitrogen, and carbon are considered. Phytoplankton biomass, as well as carbon, phosphorus, and nitrogen in algal cells must be included as state variables, all expressed in the units  $\text{g}/\text{m}^3$ . This is more complex than the constant stoichiometric approach, which is applied in most eutrophication models (see Table 7.6). The most frequent equation applied for this approach is:

$$\text{Growth of phytoplankton} = \mu_{\max} \min \left( \text{NS}/(\text{k}_n + \text{NS}), (\text{PS}/(\text{PS} + \text{k}_p)) \right) \quad (7.17)$$

where  $\mu_{\max}$  is the maximum growth rate and  $\text{k}_n$  and  $\text{k}_p$  are Michaelis-Menten half saturation constants. It presumes that phosphorus and



**FIGURE 7.4** The two-steps model of phytoplankton growth. The first step is uptake of nutrients PS, NS, and CS, followed by a growth of phytoplankton, which is dependent on the nutrient concentrations in the phytoplankton cells, PA, NA, and CA. The carbon uptake is dependent on the light, while the uptake of phosphorus and nitrogen can take place even in darkness. It is a more physiologically correct description of phytoplankton growth than the equations (7.17)

nitrogen (and maybe also silica and carbon) are taken up in a given ratio. Jørgensen (1976a) showed that it was impossible to obtain an accurate time at which the maximum phytoplankton concentration and production occurred using the simpler noncausal Monod's kinetic for phytoplankton growth. The proportions of nitrogen and phosphorus in both zooplankton and fish should be included in the model to ensure element conservation. The two-step phytoplankton growth (see Figure 7.4) is described using a growth rate coefficient  $\mu_{\max}$ , which is limited by four factors:

1. A temperature factor:

$$FT1 = \exp(A(T - T_{\text{opt}})) (T_{\text{max}}T)/(T_{\text{max}} - T_{\text{opt}})A(T_{\text{max}} - T_{\text{opt}}) \quad (7.18)$$

where  $A$ ,  $T_{\text{opt}}$ , and  $T_{\text{max}}$  are species dependent constants.  $T$  is temperature.

2. A factor for intracellular nitrogen, NC:

$$FN3 = 1 - NC_{\text{min}}/NC \quad (7.19)$$

3. A parallel factor for intracellular phosphorus:

$$FP3 = 1 - PC_{\text{min}}/PC; \text{ and similarly} \quad (7.20)$$

4. A factor for intracellular carbon:

$$FC3 = 1 - CC_{\text{min}}/CC \quad (7.21)$$

The phytoplankton growth is limited only by the minimum of the last three factors. It means that we have:

$$d\text{Phyt}/dt = \mu_{\max} \text{FT1} \cdot \min(\text{FP3}, \text{FN3}, \text{FC3}) \quad (7.22)$$

NC, PC, and CC are determined by nutrient uptake rates:

$$\text{UC} = \text{UC}_{\max} \text{FC1} \cdot \text{FC2} \cdot \text{FRAD} \quad (7.23)$$

$$\text{UN} = \text{UN}_{\max} \text{FN1} \cdot \text{FN2} \quad (7.24)$$

$$\text{UP} = \text{UP}_{\max} \cdot \text{FP1} \cdot \text{FP2} \quad (7.25)$$

where  $\text{UC}_{\max}$ ,  $\text{UN}_{\max}$ , and  $\text{UP}_{\max}$  are species-dependent constants (maximum uptake rates); generally,  $\text{UC}_{\max}$  will be greater the smaller the size of the considered phytoplankton. FCI, FNI, and FPI are expressions that give the limitations in uptake:

$$\text{FC1} = (\text{FC}_{\max} - \text{FCA}) / (\text{FCA}_{\max} - \text{FCA}_{\min}) \quad (7.26)$$

$$\text{FN1} = (\text{FN}_{\max} - \text{FNA}) / (\text{FNA}_{\max} - \text{FNA}_{\min}) \quad (7.27)$$

$$\text{FP1} = (\text{FP}_{\max} - \text{FPA}) / (\text{FPA}_{\max} - \text{FPA}_{\min}) \quad (7.28)$$

where  $\text{FCA}_{\max}$ ,  $\text{FCA}_{\min}$ ,  $\text{FNA}_{\max}$ ,  $\text{FNA}_{\min}$ ,  $\text{FPA}_{\max}$ , and  $\text{FPA}_{\min}$  are constants indicating the maximum and minimum contents, respectively, of nutrients in phytoplankton. FCA, FNA, and FPA are determined as CC/PHYT, NC/PHYT, and PC/PHYT. FC2, FN2, and FP2 give the limitations in uptake caused by the nutrient level in the lake water:

$$\text{FC2} = \text{C} / (\text{KC} + \text{C}) \quad (7.29)$$

$$\text{FN2} = \text{NS} / (\text{NS} + \text{KN}) \quad (7.30)$$

$$\text{FP2} = \text{PS} / (\text{PS} + \text{KP}) \quad (7.31)$$

C, NS, and PS are the concentrations of soluble inorganic forms in the water of carbon, nitrogen, and phosphorus. These expressions are in accordance with the Michaelis-Menten formulation. KC, KN, and KP are half-saturation constants. FRAD is a complex expression, covering the influence of solar radiation. This influence is integrated over depth and the self-shading effect is included.

The intracellular nitrogen, phosphorus, and carbon can now be determined by differential equations:

$$d\text{NC}/dt = \text{UN} \cdot \text{PHYT} - (\text{SA} + \text{GZ}/\text{F} + \text{Q}/\text{V})\text{NC} \quad (7.32)$$

$$d\text{PC}/dt = \text{UP} \cdot \text{PHYT} - (\text{SA} + \text{GZ}/\text{F} + \text{Q}/\text{V})\text{PC} \quad (7.33)$$

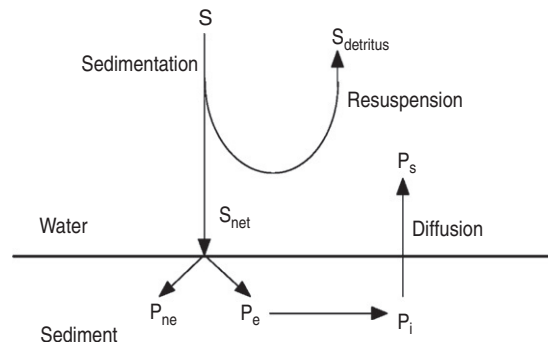
$$d\text{CC}/dt = \text{UC} \cdot \text{PHYT} - (\text{SA} + \text{RESP} + \text{GZ}/\text{F} + \text{Q}/\text{V})\text{CC} \quad (7.34)$$

where PHYT is the phytoplankton concentration, GZ, is the grazing rate corresponding to gross zooplankton growth, F is a yield factor (approximately 2/3, i.e., zooplankton utilizes 66.7% of the food), Q is the outflow rate, SA is the settling rate ( $\text{day}^{-1}$ ), and V is the volume. RC is the respiration rate, found as:

$$RC = RC_{\max}(CC/CC_{\max})^{2/3} \quad (7.35)$$

A more detailed sediment submodel is another characteristic feature of the presented model. As the sediment accumulates nutrients, it is important to describe quantitatively the processes determining the mass flows from sediment to water, particularly in shallow lakes, where the sediment may contain the major part of nutrients. To what extent will accumulated compounds in the sediment be redissolved in the lake water? The exchange processes between mud and water of phosphorus and nitrogen have been extensively studied, as these processes are important for the eutrophication of lakes. Several of the very early developed models did not consider the importance of these sediment water interactions and ignored the exchange of nutrients between mud and water. As pointed out by Jørgensen, Kamp-Nielsen, and Jacobsen (1975), this will inevitably produce a poor result. Ahlgren (1973) applied a constant flow of nutrients between sediment and water, and Dahl-Madsen and Strange-Nielsen (1974) used a simple first-order kinetic to describe the exchange rate.

A more comprehensive submodel (Figure 7.5) for the exchange of phosphorus has been developed by Jørgensen et al. (1975). The settled



**FIGURE 7.5** Sedimentation,  $S$ , divided into  $S_{\text{detritus}}$  and  $S_{\text{net}}$ .  $P_{\text{ne}}$ , nonexchangeable phosphorus in unstabilized sediment;  $P_{\text{e}}$ , exchangeable phosphorus in unstabilized sediment;  $P_{\text{i}}$ , phosphorus in interstitial water; and  $P_{\text{s}}$ , dissolved phosphorus in water.



material,  $S$ , is divided into  $S_{\text{detritus}}$  and  $S_{\text{net}}$ , the first is mineralized by microbiological activity in the water body, and the latter is material actually transported to the sediment.  $S_{\text{net}}$  can also be divided into two flows:

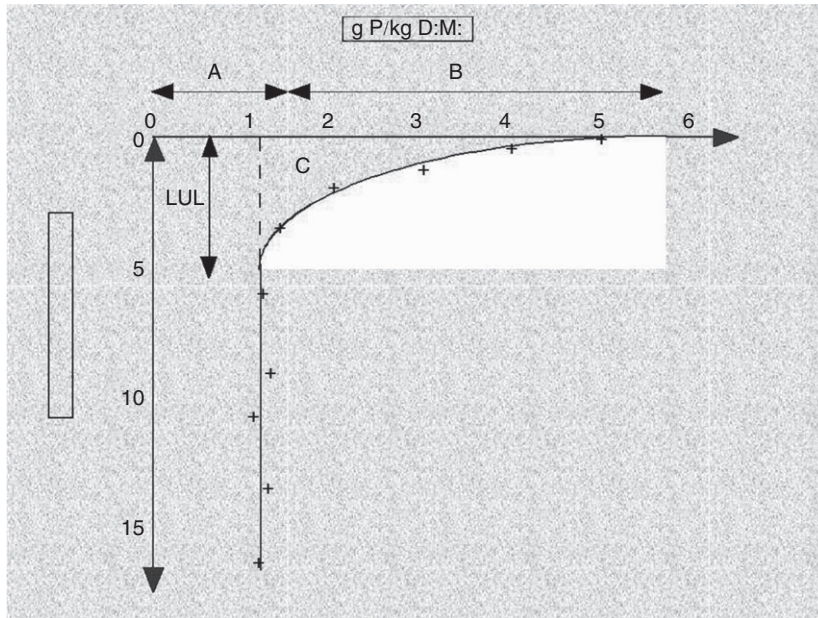
$$S_{\text{net}} = S_{\text{net,s}} + S_{\text{net,e}} \quad (7.36)$$

where  $S_{\text{net,s}}$  = flow to the stable nonexchangeable sediment, and  $S_{\text{net,e}}$  = mass flow to the exchangeable unstable sediment.

Correspondingly,  $P_{\text{ne}}$  and  $P_{\text{e}}$  — nonexchangeable and exchangeable phosphorus concentrations — both based on the total dry matter in the sediment, can also be distinguished. An analysis of the phosphorus profile in the sediment (Figure 7.6) produces the ratio,  $f$ , of the exchangeable to the total settled phosphorus:

$$f = (S_{\text{net}} - S_{\text{net,s}})/S_{\text{net}} = S_{\text{net,e}}/S_{\text{net}} \quad (7.37)$$

$$\text{and } dP_{\text{e}}/dt = a f S_{\text{net,e}} - K_5 * P_{\text{e}} K_6^{(T-20)} \quad (7.38)$$



**FIGURE 7.6** Analysis of core from Lake Esrom. mg P/g dry matter is plotted against the depth. The area C represents exchangeable phosphorus,  $f = (B.A^{-1})$ , and LUL is the unstabilized layer.

where  $a$  = factor for converting water concentration units to concentration units in the sediment ( $\text{mg P kg}^{-1} \text{ DM}$ ).  $S_{\text{net,e}}$  is found from sediment profile studies. The increases of the stabilized sediment are found by numerous methods — the application of lead isotopes, for example, is a fast and reliable method. Exchangeable phosphorus is mineralized similarly to detritus in a water body, and a first-order reaction as indicated gives a reasonably good description of the conversion of  $P_e$  into interstitial phosphorus,  $P_i$ :  $K_5 * P_e K_6^{(T-20)}$ , where  $K_5$  = a rate coefficient,  $K_6$  = a temperature coefficient, and  $T$  = temperature.

Finally, the interstitial phosphorus,  $P_i$ , is transported by diffusion from the pore water to the lake water. This process, which has been studied by Kamp-Nielsen (1975), can be described following the empirical equation (valid at  $7^\circ\text{C}$ ):

$$\text{Release of P} = 1.21 (P_i - P_s) - 1.7 \text{ (mg P m}^{-2} \text{ 24h}^{-1}) \quad (7.39)$$

where  $P_s$  is the dissolved phosphorus in the lake water.

It thus turns out that:

$$d P_i / dt = K_5 * P_e K_6^{(T-20)} - (1.21(P_i - P_s) - 1.7) \times T / 280 \quad (7.40)$$

$T$  is the absolute temperature as the release rate was found to be proportional to  $T$ . Notice that the phosphorus released from the sediment is diluted in the lake water corresponding to the ratio between the active sediment layer and the depth of the lake — see also the four state variable eutrophication model presented in [Section 7.3](#).

This submodel was validated in three case studies (Jørgensen et al., 1975) examining sediment cores in the laboratory. Kamp-Nielsen (1975) added an adsorption term to these equations.

A similar submodel for the nitrogen release has been set up by Jacobsen and Jørgensen (1975). The nitrogen release from sediment is expressed as a function of the nitrogen concentration in the sediment and the temperature, considering both aerobic and anaerobic conditions.

The grazing on phytoplankton by zooplankton,  $Z$ , and the predation on zooplankton by fish,  $F$ , are both expressed by a modified Monod expression:

$$\mu_Z = \mu_{Z_{\text{max}}}(\text{PHYT} - \text{GL}) / (\text{PHYT} - \text{KA}) \quad (7.41)$$

$$\mu_F = \mu_{F_{\text{max}}}(\text{ZOO} - \text{KS}) / (\text{ZOO} - \text{KZ}) \quad (7.42)$$

where GL, KA, KS, and KZ are constants. These expressions are according to Steele (1974). GL and KS express the very low concentrations at which grazing and predation do not take place. The time to find the food and the energy spent on searching after food is simply too high at low concentration.

The following points in the model were changed from 1979 to 1983 and this gave a better validation:

1. FC3, FN3, and FP3 were changed to:

$$(CC - CC_{\min}) / (CC_{\max} - CC_{\min}) \quad (7.43)$$

and similarly for FN3 and FP3.

2. The  $T_{\text{opt}}$  in the temperature factor was changed to the actual temperature in the lake water during the summer months to allow for temperature adaptation.
3. The temperature dependence of phytoplankton respiration was changed to an exponential expression.
4. RC was changed to:

$$RC = RC_{\max} CC / CC_{\max} \quad (7.44)$$

The exponent 2/3 in Eq. (7.35) is valid for individual cells as the surface is approximately proportional to the weight or volume of the cells, but since phytoplankton concentration is used here, application of the exponent 2/3 is irrelevant.

5. As previously mentioned, only part of the settled phosphorus is exchangeable. In the Lake Glumsø study it was found that 15% of the settled phosphorus was nonexchangeable to account for the observed phosphorus profile in the sediment. In the new version, exchangeable and nonexchangeable nitrogen were also distinguished. These changes gave a better correspondence between the modelled and the observed nitrogen balance.
6. A carrying capacity of zooplankton was introduced to give a better simulation of zooplankton and phytoplankton. Carrying capacities are often observed in ecosystems (see Eq. 2.4), but their necessity in this case may be because of a simulation of the grazing process that is too simple. Phytoplankton might not be grazed by all zooplankton species present, and some species might use detritus

as a food source. The zooplankton growth rate,  $mZ$ , is computed in accordance with these modifications as:

$$\mu Z = \mu Z_{\max} \cdot FPH \cdot FT2 \cdot F2CK \quad (7.45)$$

where  $FPH = (PHYT - GL)/(PHYT - KA)$  — see the expression [Eq. \(7.41\)](#) —  $FT2$  is a temperature regulation expression, and  $F2CK$  accounts for carrying capacity:

$$F2CK = 1 - ZOO/CK \quad (7.46)$$

$$\text{where } CK = 26 \text{ mg/L} \quad (7.47)$$

was chosen in this case.

An intensive measuring period was applied to improve parameter estimation as described in Chapter 2. The results of this effort can be summarized as follows:

- (A) The previously applied expression for the influence of temperature on phytoplankton growth — a simple Arrhenius expression  $1.05^{(T-20)}$  — produced unacceptable parameters with standard deviations that were too high. A better expression, [Eq. \(7.18\)](#), was introduced as a result of the intensive measuring period.
- (B) It was possible to improve the parameter estimation, which gives, for some of the parameters, more realistic values. Whether this would give an improved validation when observations from a period with drastic changes in the nutrients loading are available could not be stated.
- (C) Two zooplankton state variables based on phytoplankton grazing and detritus feeding were tested but did not produce any advantages.
- (D) The other expressions applied for process descriptions were confirmed.

It is necessary to validate models against an independent set of measurements. No general method of validation is available, but almost the same method suggested by WMO (1975) for validation of hydrological models was applied for this model. [Table 7.7](#) provides results of the validation improved as described previously. The following numerical validation criteria were applied:

**Table 7.7** Numerical Validation of the Described Model

Validation Criteria	State Variable	Value
Y	All	0.31
R	Ptotal (P4)	0.26
R	Psoluble (P5)	0.16
R	Ntotal (N4)	0.02
R	Nsoluble (NS)	0.14
R	Phytoplankton (CA)	0.10
R	Zooplankton (Z)	0.27
R	Production	0.03
A	Ptotal (P4)	0.12
A	Psoluble (P5)	0.18
A	Ntotal (N4)	0.07
A	Nsoluble (NS)	0.03
A	Phytoplankton (CA)	0.15
A	Zooplankton (Z)	0.00
A	Production	0.08
TE	Ptotal (P4)	105 days
TE	Psoluble (P5)	60 days
TE	Ntotal (N4)	15 days
TE	Nsoluble (NS)	15 days
TE	Phytoplankton, (CA)	0 days*
		120 days**
TE	Zooplankton (Z)	60 days
TE	Production	0 days

Notes:

\*Based on measuring suspended matter 1–60  $\mu\text{m}$ .

\*\*Based on chlorophyll.

1. Y, coefficient of variation of the residuals of errors for the state variables for the validation period, defined as:

$$Y = \frac{\sqrt{(-y_c - y_m)^2}}{n Y_{a,m}} \quad (7.48)$$

where  $y_c$  = calculated values of the state variables,  $y_m$  = measured values of the state variables,  $n$  = number of comparisons, and  $Y_{a,m}$  = average of measured values over the validation period.

- (2) R, the relative error of mean values:

$$R = (Y_{a,c} - Y_{a,m})/Y_{a,m} \quad (7.49)$$

where  $Y_{a,c}$  is the average of measured values over the validation period.

- (3) A, the relative error of maximum values:

$$A = (Y_{\max,c} - Y_{\max,m})/Y_{\max,m} \quad (7.50)$$

where  $Y_{\max,c}$  is the maximum value of the calculated state variable in the validation period, and  $Y_{\max,m}$  is the maximum value of the measured state variable in the validation period. A for the phytoplankton concentration or the production (dPhyt/dt) are often considered the most important validation criteria, as they describe the “worst-case” situation. This is also often reflected in validations of prognoses.

- (4) TE, timing error:

$$TE = \text{Date of } Y_{\max,c} - \text{date of } Y_{\max,m} \quad (7.51)$$

Y, R, and A produce the errors in relative terms. By multiplying by 100, the errors are obtained as a percentage. The standard deviation, Y, for all measured state variables, is 31%. It is the standard deviation for one comparison of model value and measured value. As the standard deviation for a comparison of  $n$  sets of model values and measured values is  $\sqrt{n}$  times smaller and  $n$  is in the order of 225, the overall average picture of the lake is given with a standard deviation of about 2%, which is acceptable. Y is generally 5 times larger for hydrodynamics models (WMO, 1975).

The relative errors of mean values, R, are 3% for production, 10% for phytoplankton, and 2% for nitrogen — all acceptable values. The relative error for total phosphorus is 26% and for zooplankton 27%, which must be considered too high. The relative errors of the maximum values, A, are from 0 to 18%, which is acceptable. The ability of the model to predict maximum production and maximum phytoplankton concentration has special interest for a eutrophication model; the relative errors of 8 and 15%, respectively, are fully acceptable.

The ability to predict the time when maximum values occur is expressed by using TE. Production and phytoplankton (use for suspended matter 1–60 m) have good agreement between model values and measured values. TE for total and soluble nitrogen is also acceptable, while the zooplankton and phosphorus values are on the high side. All in all the validation has demonstrated that the model should have value as a predictive tool, although the dynamics of phosphorus and zooplankton could be improved.

The changes in the model made between 1979 and 1983 included the six points mentioned earlier and improved the validation further, as Y was reduced from 31 to 16%.

As mentioned in the introduction to this model, it has been applied with modifications to 25 other case studies. The changes in the model were all based on ecological observations. [Table 7.8](#) reviews the modifications needed in the 25 case studies to get a workable model. By calibration carried out according to Chapter 2, it was found that the most crucial parameters were all in the range of values found in the literature. Note that the parameters were all found by:

1. Using literature values as initial guesses (see Jørgensen, S.E., Nors Nielsen and L.A. Jørgensen, 1991 and Jørgensen, L.A. Nors Nielsen and S.E. Jørgensen, 2000)
2. Using frequent measuring periods to get good first estimations of parameters
3. A first rough calibration of the model to improve parameter estimations
4. Use of an automatic calibration procedure to allow a finer calibration of 6–8 of the most important (most sensitive to the phytoplankton concentration) parameters with ranges partly based on the frequent measurements. This procedure was repeated at least twice and only when the same parameter values were found was the calibration considered satisfactory.

The presented model and other models of similar complexity are widely applied as environmental management tools. They represent what can be achieved by the use of ecological models, provided all steps of the procedure shown in Section 2.3 are carefully included in the model development. Eutrophication models represent the type of ecological model that has received most attention and effort during the last

**Table 7.8** Survey of Eutrophication Studies Based Upon the Application of a Modified Glumsø Model

<b>Ecosystem</b>	<b>Modification</b>	<b>Level*</b>
Glumsø, version A	Basis version	7
Glumsø, version B	Nonexchangeable nitrogen	7
Ringkøbing Firth	Boxes, nitrogen fixation	5
Lake Victoria	Boxes, thermocline, other food chain	4
Lake Kyoga	Other food chain	4
Lake Mobuto Sese Seko	Boxes, thermocline, other food chain	4
Lake Fure	Boxes, nitrogen fixation, thermocline	7
Lake Esrom	Boxes, Si-cycle, thermocline	4
Lake Gyrstinge	Level fluctuations, sediment exposed to air	4–5
Lake Lyngby	Basis version	6
Lake Bergunda	Nitrogen fixation	2
Broia Reservoir	Macrophytes, 2 boxes	2
Lake Great Kattinge	Resuspension	5
Lake Svogerslev	Resuspension	5
Lake Bue	Resuspension	5
Lake Kornerup	Resuspension	5
Lake Søbygaard	SDM	7
Lake Balaton	Adsorption to suspended matter	2
Roskilde Fjord	Complex hydrodynamics	4
Lagoon of Venice	Ulva/Zostera competition	6
Lake Annone	SDM	6
Lake Balaton	SDM	6
Lake Mogan, Ankara	Only P cycle, competition submerged vegetation/ phytoplankton + SDM	6
Stadsgraven, Copenhagen	4–6 interconnected basins	5 (level 6: 93)
Internal lakes of Copenhagen	5–6 interconnected basins	5

SDM, Structurally Dynamic Model.

for\*, see p. 207



35 years. The results reflect what could be obtained for all ecosystem models, if sufficient effort is used in their examination and development.

Level 1: Conceptual diagram selected

Level 2: Verification carried out

Level 3: Calibration using intensive measurements

Level 4: Calibration of entire model

Level 5: Validation — object function and regression coefficient are found

Level 6: Validation of a prognosis for significant changed loading or development of structurally dynamic models (SDMs)

Level 7: Validation of a prognosis and development of SDMs

As the validation was acceptable, the model was applied to predict the production, phytoplankton concentration, and transparency under conditions in which the phosphorus input to the lake was reduced 90%. Such a reduction was easy to achieve by a well-controlled chemical precipitation. Before the reduction of the phosphorus input, the lake was very eutrophied, which can be seen by the following typical observations:

Total P  $\text{g}/\text{m}^3$ : 1.1

Phytoplankton concentration peak value: ( $\text{mg chl. a}/\text{m}^3$ ) 850

Production ( $\text{g C}/(\text{m}^2 \text{ year})$ ) 1050

Minimum transparency at spring bloom (m) 0.18

Fortunately, the water residence time of Lake Glumsø is only 6 months, so it was possible to validate the simulation properly within a few years. A comparison of the prediction and the actual observations after 90% reduction of the phosphorus input is shown in [Table 7.9](#). The standard deviations indicated in the table are for the prediction based on the validation results shown earlier and for the measurement based on a general determination of the standard deviations for measurement on 10%, relatively.

The prediction validation is fully acceptable except for the daily production ( $\text{g C}/(\text{m}^2 \text{ 24h})$ ) at spring bloom during the second year. In the beginning of the second year, the phytoplankton species shifted from *Scenedesmus* to various species of diatoms. It is always more difficult

**Table 7.9** Validation of the Prognosis for Glumsø Lake

Comparison of:	Prediction			Measurements	
	Time	Value	St. Dev.	Value	St. Dev.
Min. transparency	1 year	0.20 m	0.03	0.20 m	0.02
Min. transparency	2 year	0.30 m	0.05	0.25 m	0.025
Min. transparency	3 year	0.45m	0.07	0.50 m	0.05
Max. production	2 year	6.0 gC/24hm <sup>2</sup>	0.3	11.0 gC/24hm <sup>2</sup>	1.1
Max. production	3 year	5.0 gC/24hm <sup>2</sup>	0.3	6.2 gC/24hm <sup>2</sup>	0.6
Max. chl.a.	1 year	750 mg/m <sup>3</sup>	112	800 mg/m <sup>3</sup>	80
Max. chl.a	2 year	520 mg/m <sup>3</sup>	78	550 mg/m <sup>3</sup>	55
Max. chl.a	3 year	320 mg/m <sup>3</sup>	48	380 mg/m <sup>3</sup>	38
Annual production	2 year	720 gC/y m <sup>2</sup>	15*	750 gC/y m <sup>3</sup>	19*
Annual production	3 year	650 gC/y m <sup>3</sup>	13*	670 gC/y m <sup>3</sup>	17*

Notes:

\*A standard deviation of 8% is used for the prognosis divided by  $\sqrt{15}$  and 10% divided by  $\sqrt{15}$  for the measurements, because the determination of the annual production is based on 15 measurements and 15 prognosis values.

to predict accurately a rate, such as production, than a state variable, such as phytoplankton.

The shift implied that the well-determined parameters for phytoplankton were no longer valid, which may explain the discrepancy between the prediction and the observations, particularly the second year after reducing the phosphorus loading. However, the shift has clearly demonstrated the need for a structurally dynamic modelling approach, as discussed in Chapter 10 (see also Jørgensen et al., 2004).

## 7.6. Model of Subsurface Wetland

The model presented in this section very clearly illustrates the basic ideas behind biogeochemical models. It was developed as a result of a Danida project promoting the cooperation between Copenhagen and Dar es Salaam University in Tanzania. Later, the UNEP-IETC developed software based on this model that could be used by developing

countries to design subsurface wetlands. The software was called Sub-wet. Fleming College, the center for alternative waste water treatment, wanted to use the software for wetland design in cold climates, so they supported further development of the software to be applied both for warm and cold climates. This version of the software is denoted Sub-wet 2.0 and it is available for download from the home page of UNEP-IETC (2009). See also Jørgensen, Chon, and Recknagel (2009). The model presentation in the next section follows the Sub-wet 2.0 manual used as the basis for the model information.

The scope of the model is to design and manage a subsurface wetland based on defined removal efficiencies of organic matter (expressed in terms of BOD<sub>5</sub>), nitrate, ammonium, organic nitrogen, and phosphorus. Thus, it is necessary to know the:

1. Water flow
2. Concentrations of the previously mentioned constituents in the water
3. Required removal efficiencies for these constituents (i.e., their concentrations in the treated water).

The modelled subsurface wetland consists of a constructed or a natural wetland area. The constructed wetland has gravel soil, ensuring a good water flow through the wetland. The core design parameter is the area and the volume of the wetland (denoted V and A).

The conceptual diagram of the model is presented in [Figures 7.7–7.9](#). [Figure 7.7](#) illustrates the organic matter sub-model, while [Figure 7.8](#) illustrates the nitrogen submodel with three different nitrogen compounds (organic nitrogen, ammonium and nitrate). [Figure 7.9](#) illustrates the phosphorus submodel. The model state variables are: BOD<sub>5</sub>, nitrate (NIT), ammonium (AMM), total phosphorus (TP), and organic nitrogen (ORN) in 5 successive boxes, denoted A, B, C, D, and E. Totally, the model has 25 state variables, all using the units mg/L or g/m<sup>3</sup>:

BOD<sub>5</sub>-A, BOD<sub>5</sub>-B, BOD<sub>5</sub>-C, BOD<sub>5</sub>-D, BOD<sub>5</sub>-E (mg O<sub>2</sub>/L)

NIT-A, NIT-B, NIT-C, NIT-D, NIT-E (mg N/L)

AMM-A, AMM-B, AMM-C, AMM-D, AMM-E (mg N/L)

TPO-A, TPO-B, TPO-C, TPO-D, TPO-E (mg P/L)

ORN-A, ORN-B, ORN-C, ORN-D, ORN-E (mg N/L)

The model variables are expressed by three letters (e.g., NIT for nitrate), followed by IN, OUT, or A,B,C,D,E, with the parameters using two letters.

The model has the following forcing functions, which the user must specify for a given model run:

Volume of wetland ( $\text{m}^3$ ; possible range 10–10,000,000)

Flow of water (QIN, expressed as  $\text{m}^3/24 \text{ h}$ ; possible range 1–1,000,000)

Porosity (as fraction of POR; no unit; range 0–1; default value 0.46)

Input concentration of  $\text{BOD}_5$  (BOD-IN;  $\text{mg O}_2/\text{L}$ ; range 0–1000)

Input concentration of ammonium (AMM-IN;  $\text{mg N/L}$ ; range 0–100)

Input concentration of nitrate (NIT-IN;  $\text{mg N/L}$ ; range 0–100)

Input concentration of total phosphorus (TPO-IN;  $\text{mg P/L}$ ; range 0–50)

Concentration in of organic nitrogen (ORN-IN;  $\text{mg N/L}$  (range 0–200)

Fraction of  $\text{BOD}_5$  as suspended matter (POM; no unit; range 0–1)

Fraction of organic-N matter as suspended matter (PON; no unit)

Fraction of phosphorus as suspended matter (POP; no unit)

Average oxygen concentration in Box A (AOX;  $\text{mg/L}$ ; range 0–20)

Average oxygen concentration in Box B (BOX;  $\text{mg/L}$ ; range 0–20)

Average oxygen concentration in Box C (COX;  $\text{mg/L}$ ; range 0–20)

Average oxygen concentration in Box D (DOX;  $\text{mg/L}$ ; range 0–20)

Average oxygen concentration in Box E (EOX;  $\text{mg/L}$ ; range 0–20)

Default value for AOX, BOX, COX, DOX, EOX = 0.4  $\text{mg/L}$

Average Temperature (TEMP; as function of time; daily average temperature is listed for the number of days to be simulated with the model)

The length of model simulations must be indicated as number of days.

The following forcing functions are calculated, and included in the forcing function table, along with the forcing functions:

Retention time,  $\text{RTT} (= \text{VOL} \cdot \text{POR} / \text{Q}; 24\text{h})$

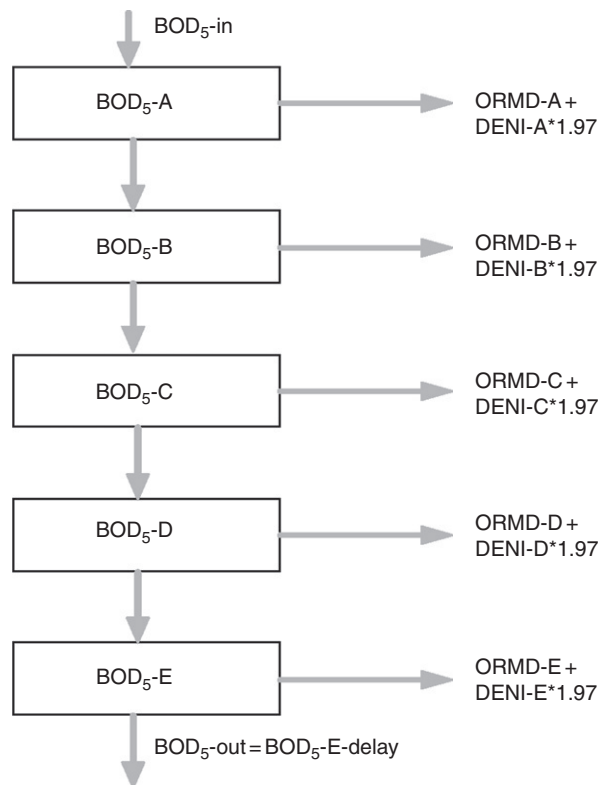
Retention time per box,  $\text{RTB} (= \text{RTT} / 5; 24\text{h})$

Box volume,  $\text{BOV} (= \text{VOL} \cdot \text{POR} / 5)$

### 7.6.1. Process Equations

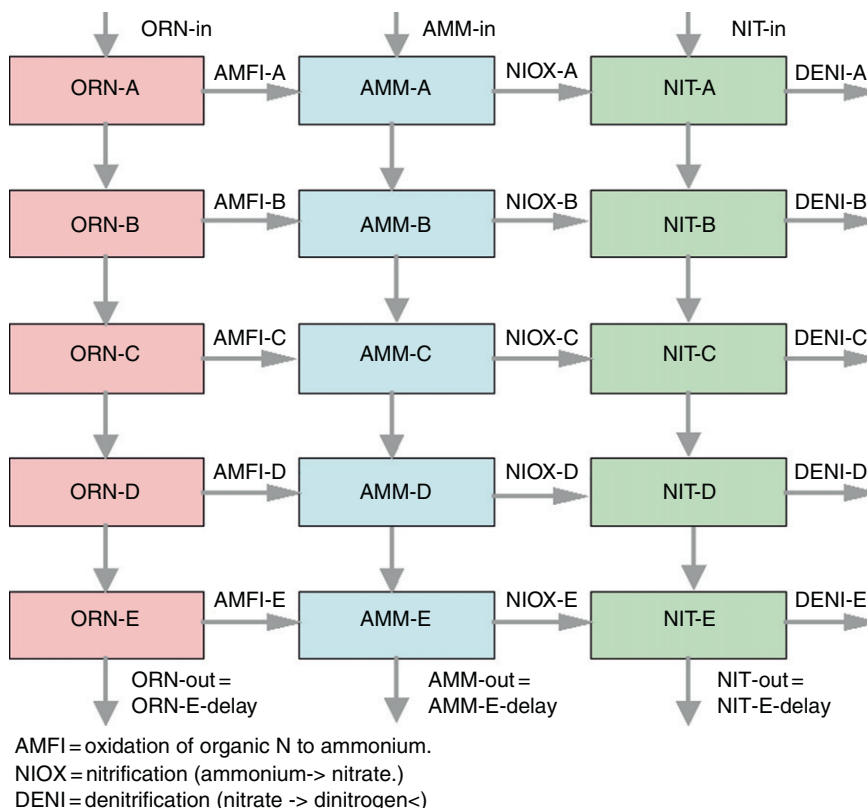
A continuous transfer takes place from one state variable to another in the model simulations. This section identifies the processes that take place in the subsurface wetland. It is noted that the same processes take place in each box, although the concentrations are different in each box. Thus, the equations are repeated in the model program with an indication of the concentrations in the five different model boxes — A,B,C,D, and E. All of the processes are expressed by four letters, followed by A, B, C, D, or E, corresponding to the five boxes. It is reiterated that the model expressions are the same for each box, although the applied concentrations of the modelled materials differ for each box. Exponent is expressed by the notation ( $\wedge$ ).

The following equations are repeated in each box with an indication of the letters of the box (Figures 7.7–7.9):



ORMD = decomposition of organic matter by oxidation  
 DENI\* 1.97 = decomposition of organic matter by denitrification

**FIGURE 7.7** The BOD<sub>5</sub> submodel.



**FIGURE 7.8** The nitrogen submodel illustrating the three nitrogen compounds (organic-N, ammonium, and nitrate).

Ammonification = AMFI =  $ORN \cdot AC \cdot TA^{(TEMP-20)}$

Nitrification = NIOX =  $AMM \cdot NC \cdot INOX \cdot TN^{(TEMP-20)} / (AMM + MA)$

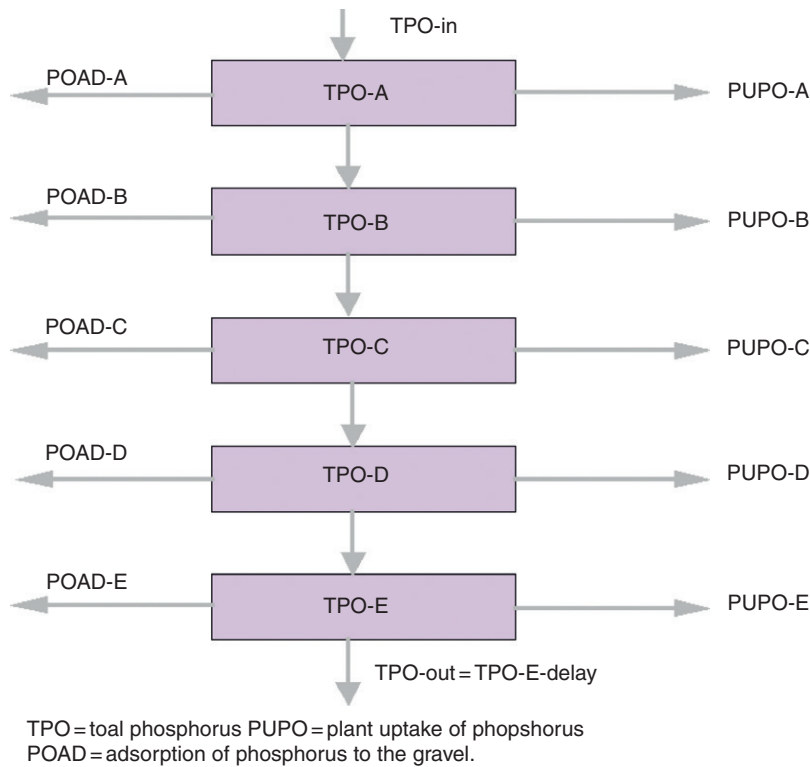
Oxidation of  $BOD_5$  = ORMD =  $BOD_5 \cdot OC \cdot INOO \cdot TO^{(TEMP-20)}$

Denitrification = DENI =  $NIT \cdot DC \cdot TD^{(TEMP-20)} / (NIT + MN)$

$INOX-A = AOX / (AOX + KO)$ , and so on for boxes B, C, D, and E, using the notations BOX, COX, DOX, and EOX; however, KO is the same parameter for all five boxes

$INOO-A = AOX / (AOX + OO)$ , and so on for boxes B, C, D, and E, using the notations BOX, COX, DOX, and EOX; however, OO is the same parameter for all five boxes.

Plant uptake of ammonium = PUAM =  $AMM \cdot PA$



**FIGURE 7.9** The phosphorus submodel.

Plant uptake of nitrate =  $PUNI = NIT * PN$

Plant uptake of phosphorus =  $PUPO-A = TPO-A * PP * (1 - POP)$  for box A, while  $PUPO-B = TPO-B * PP$ ;  $PUPO-C = TPO-C * PP$ ;  $PUPO-D = TPO-D * PP$ ; and  $PUPO-E = TPO-E * PP$  (note that the multiplication by  $(1 - POP)$  only applied to box A)

Adsorption of phosphorus =  $POAD-A = TPO-A * (1 - POP) * (POR) - AF * (1 - POR)$ , if  $POAD > 0$ ; otherwise  $POAD = 0$  for box A, while the following equation is applied for the other boxes:  $POAD = TPO * POR - AF * (1 - POR)$ .

The model uses delay values (i.e., the concentrations of the five constituents in the five boxes during one box-retention time (RTB) earlier). For example:

$AMM-A-delay = AMM-A$  at time  $t - RTB$ , when  $t > RTB$ ; if  $t < RTB$ ,  $AMM-A-delay$  is 0.

These equations are repeated for all five constituents in all five boxes, and the delay concentrations are indicated with “-delay”.

Further, the simulated results also are used to determine the removal efficiencies, which are also shown on graphs. They are found as function of time, as follows:

$$\text{Efficiency of BOD}_5\text{-removal (\%)} = 100 * (\text{BOD}_5\text{-in} - \text{BOD}_5\text{-out}) / \text{BOD}_5\text{-in}$$

$$\text{Efficiency of Nitrate removal (\%)} = 100 * (\text{NIT-in} - \text{NIT-out}) / \text{NIT-in}$$

$$\text{Efficiency of Ammonium removal (\%)} = 100 * (\text{AMM-in} - \text{AMM-out}) / \text{AMM-in}$$

$$\text{Efficiency of Organic-N removal (\%)} = 100 * (\text{ORN-in} - \text{ORN-out}) / \text{ORN-in}$$

$$\text{Efficiency of Nitrogen removal (\%)} = 100 * ((\text{NIT-in} + \text{AMM-in} + \text{ORN-in}) - (\text{NIT-out} + \text{AMM-out} + \text{ORN-out})) / (\text{NIT-in} + \text{AMM-in} + \text{ORN-in})$$

$$\text{Efficiency of Phosphorus removal (\%)} = 100 * (\text{TPO-in} - \text{TPO-out}) / \text{TPO-in}$$

### 7.6.2. Parameters

The model parameters are as follows: (The values correspond to the parameters valid for warm climate conditions. Other parameters are recommended for use in cold climate; see the software.

$$\text{AC} = 0.05\text{--}0.8 \text{ [default value } 0.5 \text{ (1/24h)]}$$

$$\text{NC} = 0.1\text{--}1.5 \text{ [default value } 0.8 \text{ (1/24h)]}$$

$$\text{OC} = 0.05\text{--}0.8 \text{ [default value } 0.5 \text{ (1/24h)]}$$

$$\text{DC} = 0.25\text{--}5 \text{ [default value } 2.2 \text{ (1/24h)]}$$

$$\text{TA} = 1.02\text{--}1.06 \text{ [default value } 1.04 \text{ (no unit)]}$$

$$\text{TN} = 1.02\text{--}1.07 \text{ [default value } 1.047 \text{ (no unit)]}$$

$$\text{TO} = 1.02\text{--}1.06 \text{ [default value } 1.04 \text{ (no unit)]}$$

$$\text{TD} = 1.05\text{--}1.12 \text{ [default value } 1.09 \text{ (no unit)]}$$

$$\text{KO} = 0.1\text{--}2 \text{ [default value } 1.3 \text{ (mg/L)]}$$

$$\text{OO} = 0.1\text{--}2 \text{ [default value } 1.3 \text{ (mg/L)]}$$

$$\text{MA} = 0.05\text{--}2 \text{ [default value } 1 \text{ (mg/L)]}$$

$$\text{MN} = 0.01\text{--}1 \text{ [default value } 0.1 \text{ (mg/L)]}$$

$$\text{PA} = 0.00\text{--}1 \text{ [default value } 0.01 \text{ (1/24h)]}$$



PN = 0.00–1 [default value 0.01 (1/24h)]

PP = 0.00–1 [default value 0.003 (1/24h)]

AF = 0–100 [default value 1.0]

### 7.6.3. Differential Equations

The 25 differential equations in the model are as follows:

$$\text{BOV} \cdot d \text{ BOD-5-A} / dt = \text{QIN} \cdot \text{BOD-IN} - \text{QIN} \cdot (1 - \text{POM}) \cdot \text{BOD-A-delay} -$$

$$\text{BOV} \cdot \text{ORMD-A-DENI-A} \cdot 1.97$$

$$\text{BOV} \cdot d \text{ BOD-5-B} / dt = \text{QIN} \cdot (1 - \text{POM}) \cdot \text{BOD-A-delay} - \text{BOV} \cdot \text{ORMD-B} -$$

$$\text{QIN} \cdot \text{BOD-B-delay} - \text{DENI-B} \cdot 1.97$$

$$\text{BOV} \cdot d \text{ BOD-5-C} / dt = \text{QIN} \cdot \text{BOD-B-delay} - \text{BOV} \cdot \text{ORMD-C} -$$

$$\text{QIN} \cdot \text{BOD-C-delay} - \text{DENI-C} \cdot 1.97$$

$$\text{BOV} \cdot d \text{ BOD-5-D} / dt = \text{QIN} \cdot \text{BOD-C-delay} - \text{BOV} \cdot \text{ORMD-D} -$$

$$\text{QIN} \cdot \text{BOD-D-delay} - \text{DENI-D} \cdot 1.97$$

$$\text{BOV} \cdot d \text{ BOD-5-E} / dt = \text{QIN} \cdot \text{BOD-D-delay} - \text{BOV} \cdot \text{ORMD-E} -$$

$$\text{QIN} \cdot \text{BOD-E-delay} - \text{DENI-E} \cdot 1.97$$

(QIN\*BOD-E-delay indicates BOD<sub>5</sub>-OUT, which is eventually shown on a graph, together with measured values of the BOD<sub>5</sub>-OUT, while BOD<sub>5</sub>-A, B, C, D, and E are shown in a table as function of time)

$$\text{BOV} \cdot d \text{ NIT-A} / dt = \text{QIN} \cdot \text{NIT-IN} - \text{QIN} \cdot \text{NIT-A-delay} - \text{BOV} \cdot \text{DENI-A} +$$

$$\text{BOV} \cdot \text{NIOX-A} - \text{BOV} \cdot \text{PUNI-A};$$

$$\text{BOV} \cdot d \text{ NIT-B} / dt = \text{QIN} \cdot \text{NIT-A-delay} - \text{BOV} \cdot \text{DENI-B} + \text{BOV} \cdot \text{NIOX-B} -$$

$$\text{BOV} \cdot \text{PUNI-B} - \text{QIN} \cdot \text{NIT-B-delay}$$

$$\text{BOV} \cdot d \text{ NIT-C} / dt = \text{QIN} \cdot \text{NIT-B-delay} - \text{BOV} \cdot \text{DENI-C} + \text{BOV} \cdot \text{NIOX-C} -$$

$$\text{BOV} \cdot \text{PUNI-C} - \text{QIN} \cdot \text{NIT-C-delay}$$

$$\text{BOV} \cdot d \text{ NIT-D} / dt = \text{QIN} \cdot \text{NIT-C-delay} - \text{BOV} \cdot \text{DENI-D} + \text{BOV} \cdot \text{NIOX-D} -$$

$$\text{BOV} \cdot \text{PUNI-D} - \text{QIN} \cdot \text{NIT-D-delay}$$

$$\text{BOV} \cdot d \text{ NIT-E} / dt = \text{QIN} \cdot \text{NIT-D-delay} - \text{BOV} \cdot \text{DENI-E} + \text{BOV} \cdot \text{NIOX-E} -$$

$$\text{BOV} \cdot \text{PUNI-E} - \text{QIN} \cdot \text{NIT-E-delay}$$

(QIN\*NIT-E-delay indicates NIT-OUT, which is eventually shown on a graph, together with measured values of NIT-OUT, while NIT-A, NIT-B, NIT-C, NIT-D, and NIT-E are all shown in a table as a function of time)

$$\text{BOV} \cdot d \text{ AMM-A} / dt = \text{QIN} \cdot \text{AMM-IN} - \text{QIN} \cdot \text{AMM-A-delay} -$$

$$\text{BOV} \cdot \text{NIOX-A} + \text{BOV} \cdot \text{AMFI-A} - \text{BOV} \cdot \text{PUAM-A}$$

$$\text{BOV} \cdot d \text{ AMM-B} / dt = \text{QIN} \cdot \text{AMM-A-delay} + \text{BOV} \cdot \text{AMFI-B} -$$

$$\text{BOV} \cdot \text{NIOX-B} - \text{BOV} \cdot \text{PUAM-B} - \text{QIN} \cdot \text{AMM-B-delay}$$

$$\text{BOV}^*\text{dAMM-C}/\text{dt} = \text{QIN}^*\text{AMM-B-delay} + \text{BOV}^*\text{AMFI-C} - \text{BOV}^*\text{NIOX-C} - \text{BOV}^*\text{PUAM-C} - \text{QIN}^*\text{AMM-C-delay}$$

$$\text{BOV}^*\text{dAMM-D}/\text{dt} = \text{QIN}^*\text{AMM-C-delay} + \text{BOV}^*\text{AMFI-D} - \text{BOV}^*\text{NIOX-D} - \text{BOV}^*\text{PUAM-D} - \text{QIN}^*\text{AMM-D-delay}$$

$$\text{BOV}^*\text{dAMM-E}/\text{dt} = \text{QIN}^*\text{NIT-D-delay} + \text{BOV}^*\text{AMFI-E} - \text{BOV}^*\text{NIOX-E} - \text{BOV}^*\text{PUNI-E} - \text{QIN}^*\text{AMM-E-delay}$$
 (QIN\*AMM-E-delay indicates AMM-OUT, which is eventually shown on a graph, together with measured values of AMM-OUT, while AMM-A, AMM-B, AMM-C, AMM-D, and AMM-E are all shown in a table as a function of time);

$$\text{BOV}^*\text{dORN-A}/\text{dt} = \text{QIN}^*\text{ORN-IN} - \text{QIN}^*(1-\text{PON})^*\text{ORN-A-delay} - \text{BOV}^*\text{AMFI-A}$$

$$\text{BOV}^*\text{dORN-B}/\text{dt} = \text{QIN}^*\text{ORN-A-delay} - \text{BOV}^*\text{AMFI-B} - \text{QIN}^*\text{ORN-B-delay}$$

$$\text{BOV}^*\text{dORN-C}/\text{dt} = \text{QIN}^*\text{ORN-B-delay} - \text{BOV}^*\text{AMFI-C} - \text{QIN}^*\text{ORN-C-delay}$$

$$\text{BOV}^*\text{dORN-D}/\text{dt} = \text{QIN}^*\text{ORN-C-delay} - \text{BOV}^*\text{AMFI-D} - \text{QIN}^*\text{ORN-D-delay}$$

$$\text{BOV}^*\text{dORN-E}/\text{dt} = \text{QIN}^*\text{ORN-D-delay} - \text{BOV}^*\text{AMFI-E} - \text{QIN}^*\text{ORN-E-delay}$$
 (IN\*ORN-E-delay indicates ORN-OUT, which is eventually shown on a graph, together with measured values of ORN-OUT, while ORN-A, ORN-B, ORN-C, ORN-D, and ORN-E are all shown in a table as a function of time)

$$\text{BOV}^*\text{dTPO-A}/\text{dt} = \text{QIN}^*\text{TPO-IN} - \text{QIN}^*(1-\text{POP})^*\text{TPO-A-delay} - \text{BOV}^*\text{PUPO-A} - \text{BOV}^*\text{POAD-A}$$

$$\text{BOV}^*\text{dTPO-B}/\text{dt} = \text{QIN}^*(1-\text{POP})^*\text{TPO-A-delay} - \text{BOV}^*\text{PUPO-B} - \text{BOV}^*\text{POAD-B} - \text{QIN}^*\text{TPO-B-delay}$$

$$\text{BOV}^*\text{dTPO-C}/\text{dt} = \text{QIN}^*\text{TPO-B-delay} - \text{BOV}^*\text{PUPO-C} - \text{BOV}^*\text{POAD-C} - \text{QIN}^*\text{TPO-C-delay}$$

$$\text{BOV}^*\text{dTPO-D}/\text{dt} = \text{QIN}^*\text{TPO-C-delay} - \text{BOV}^*\text{PUPO-D} - \text{BOV}^*\text{POAD-D} - \text{QIN}^*\text{TPO-D-delay}$$

$$\text{BOV}^*\text{dTPO-E}/\text{dt} = \text{QIN}^*\text{TPO-D-delay} - \text{BOV}^*\text{PUPO-E} - \text{BOV}^*\text{POAD-E} - \text{QIN}^*\text{TPO-E-delay}$$
 (QIN\*TPO-E-delay indicates TPO-OUT, which is eventually shown on a graph, together with measured values of TPO-OUT, while TPO-A, TPO-B, TPO-C, TPO-D. and TPO-E are all shown in a table as a function of time).

#### 7.6.4. Model Results

As previously mentioned, the simulated values of BOD<sub>5</sub>-out, nitrate-out (NIT-out), ammonium-out (AMM-out), total phosphorus-out (TPO-out), and organic nitrogen-out (ORN-out) are shown in the form of tables and graphs. If the measured values are available, then they are shown on the same graphs to allow for a direct comparison.

The simulated results of the removal efficiencies also are shown on graphs, including:

- Efficiency of BOD<sub>5</sub>-removal (%)
- Efficiency of nitrate removal (%)
- Efficiency of ammonium removal (%)
- Efficiency of organic-N removal (%)
- Efficiency of nitrogen removal (%)
- Efficiency of phosphorus removal (%)

It also may be useful to include the predicted concentrations of the five constituents in the five boxes as a means of illustrating where the removal processes are most effective in the wetland and where they are less effective. It may be possible to apply such information to improve the overall removal efficiencies by imposed changes in the composition of the waste water, or by changes directly in the wetland (e.g., addition of oxygen). The predicted concentrations in the boxes obtained with the model simulations are listed in a table for each day in the simulation period as follows: BOD<sub>5</sub>-A, BOD<sub>5</sub>-B, BOD<sub>5</sub>-C, BOD<sub>5</sub>-D, BOD<sub>5</sub>-E, NIT-A, NIT-B, NIT-C, NIT-D, NIT-E, AMM-A, AMM-B, AMM-C, AMM-D, AMM-E, TPO-A, TPO-B, TPO-C, TPO-D, TPO-E, ORN-A, ORN-B, ORN-C, ORN-D, and ORN-E.

#### 7.6.5. Practical Information About Forcing Functions and Parameters

Usually, the model is applied to design a wetland that has not yet been constructed. Thus, it is recommended that the following information is obtained to indicate the forcing functions:

1. Measure the temperature every 6 hours, for example, in a shallow aquatic ecosystem (i.e., before the wetland is constructed, and directly

in the wetland after it has been constructed) to get an initial indication of the temperature variations. Alternatively, use some other local temperature measurements. Find the daily average temperature to be listed on the forcing function screen image. Although the temperature expression is not linear, using the average daily temperature for the temperature expression applied herein is only a minor error.

2. Use the default values indicated when no information about the forcing functions is available.
3. For the uptake rate coefficients of nutrients (nitrate, ammonium, and phosphorus; PA, PN, and PP), use knowledge about the phosphorus (P) and nitrogen (N) content and the growth rate of plants that will be applied in the wetland.

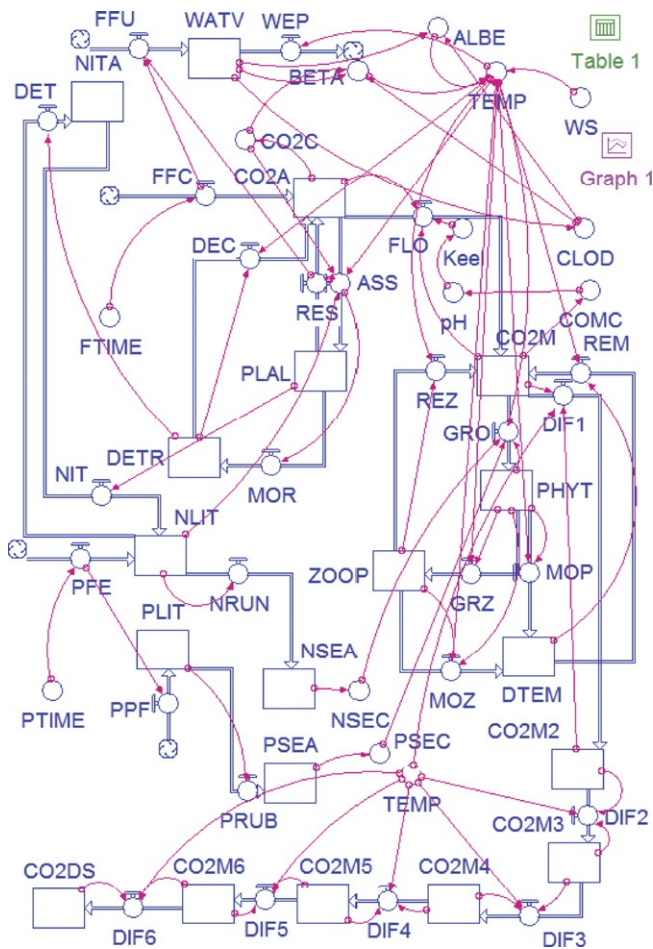
#### 7.6.6. Use of the Model for Wetland Design

If the model is used to design a wetland that has not yet been constructed, then the concentrations in the wetland, the water flow through the wetland, and the expected concentrations after wetland treatment should be known. The model is then used to predict the results for simulating different volumes. The simulated results that meet the criteria for the treated water are used, and the corresponding volume is used for the design. It is recommended that a volume 10–15% greater than that predicted with this method be used to take into account the uncertainties of the model. Further, a depth of 0.6–1.00 m is used and a maximum flow rate of about 1.25 m/h applied in order to determine the width and length of the wetland.

### 7.7. Global Warming Model

Global climate change due to the emission of greenhouse gases such as carbon dioxide, methane, and nitrogen oxides is probably the environmental problem that has attracted most recent attention. It is therefore not surprising that many models have been developed to predict the temperature change as a result of the emission of greenhouse gases. Some of the global warming models are extremely complex and detailed. They consider not only the change of the average global temperature but also how the temperature is distributed geographically. These models are usually developed by climatologists and require an enormous computer

capacity. It is, however, sufficient to reveal a relationship between the emission of greenhouse gases and the global average temperature, which can be done by much smaller models. A global warming model that can predict the increase of the global average temperature is presented in this section to illustrate an ecological modelling approach for this central environmental problem. The model is developed using of STELLA and the diagram is shown in Figure 7.10. The model equations using the STELLA format are shown Table 7.10. The model has the following *state variables*:



**FIGURE 7.10** The global warming model presented in Section 7.6.

**Table 7.10** The Global Warming Model: Equations in the STELLA Format

---

```

CO2A(t) = CO2A(t - dt) + (FFC + DEC + RES - ASS - FLO) * dt
INIT CO2A = 775
INFLOWS:
FFC = 6*FTIME*1.02^TIME
DEC = DETR*66*1.05^(TEMP-15.2)/1500
RES = 0.5*ASS
OUTFLOWS:
ASS = (120*13*CO2C)/(7*(CO2C+300))*(NLIT/865)*1.05^(TEMP-15.2)
FLO = 0.15*CO2M*((CO2A-775)/CO2A)/(Keel)
CO2DS(t) = CO2DS(t - dt) + (DIF6) * dt
INIT CO2DS = 92094
INFLOWS:
DIF6 = 3987*((CO2M6/125-CO2DS/2800)/(2800))*(TEMP/15.2)^0.5
CO2M(t) = CO2M(t - dt) + (FLO + REZ + REM - GRO - DIF1) * dt
INIT CO2M = 2466.8
INFLOWS:
FLO = 0.15*CO2M*((CO2A-775)/CO2A)/(Keel)
REZ = ZOOP*10*1.05^(TEMP-15.2)
REM = 0.02*DTEM*1.05^(TEMP-15.2)
OUTFLOWS:
GRO = PHYT*(1-PHYT/20)*1.05^(TEMP-15.2)*15.3*MAX(NSEC/(NSEC+2*10^(-7)),PSEC/(PSEC+3.5*10^(-8)))
DIF1 = (3987*(CO2M/75-CO2M2/125)/75)*(TEMP/15.2)^0.5
CO2M2(t) = CO2M2(t - dt) + (DIF1 - DIF2) * dt
INIT CO2M2 = 4110
INFLOWS:
DIF1 = (3987*(CO2M/75-CO2M2/125)/75)*(TEMP/15.2)^0.5
OUTFLOWS:
DIF2 = (3987*(CO2M2-CO2M3)/(125*125))*(TEMP/15.2)^0.5
CO2M3(t) = CO2M3(t - dt) + (DIF2 - DIF3) * dt
INIT CO2M3 = 4110
INFLOWS:
DIF2 = (3987*(CO2M2-CO2M3)/(125*125))*(TEMP/15.2)^0.5
OUTFLOWS:
DIF3 = 3987*((CO2M3-CO2M4)/(125*125))*(TEMP/15.2)^0.5
CO2M4(t) = CO2M4(t - dt) + (DIF3 - DIF4) * dt
INIT CO2M4 = 4110
INFLOWS:
DIF3 = 3987*((CO2M3-CO2M4)/(125*125))*(TEMP/15.2)^0.5
OUTFLOWS:
DIF4 = 3987*((CO2M4-CO2M5)/(125*125))*(TEMP/15.2)^0.5
CO2M5(t) = CO2M5(t - dt) + (DIF4 - DIF5) * dt
INIT CO2M5 = 4110
INFLOWS:
DIF4 = 3987*((CO2M4-CO2M5)/(125*125))*(TEMP/15.2)^0.5
OUTFLOWS:
DIF5 = 3987*((CO2M5-CO2M6)/(125*125))*(TEMP/15.2)^0.5
CO2M6(t) = CO2M6(t - dt) + (DIF5 - DIF6) * dt

```

---

**Table 7.10** The Global Warming Model: Equations in the STELLA Format—cont'd

---

```

INIT CO2M6 = 4110
INFLOWS:
DIF5 = 3987*((CO2M5-CO2M6)/(125*125))*(TEMP/15.2)^0.5
OUTFLOWS:
DIF6 = 3987*((CO2M6/125-CO2DS/2800)/(2800))*(TEMP/
15.2)^0.5
DETR(t) = DETR(t - dt) + (MOR - DEC) * dt
INIT DETR = 1500
INFLOWS:
MOR = 0.49*ASS
OUTFLOWS:
DEC = DETR*66*1.05^(TEMP-15.2)/1500
DTEM(t) = DTEM(t - dt) + (MOP + MOZ - REM) * dt
INIT DTEM = 3000
INFLOWS:
MOP = PHYT*4.5*1.05^(TEMP-15.2)
MOZ = (4.8*ZOO+0.2222*ZOO*PHYT)*1.05^(TEMP-15.2)
OUTFLOWS:
REM = 0.02*DTEM*1.05^(TEMP-15.2)
NITA(t) = NITA(t - dt) + (DET - NIT) * dt
INIT NITA = 3800000
INFLOWS:
DET = 0.000063*DETR
OUTFLOWS:
NIT = PLAL*0.00016
NLIT(t) = NLIT(t - dt) + (PFE + NIT - DET - NRUN) * dt
INIT NLIT = 852
INFLOWS:
PFE = 0.03*PTIME^TIME
NIT = PLAL*0.00016
OUTFLOWS:
DET = 0.000063*DETR
NRUN = NLIT*0.000214
NSEA(t) = NSEA(t - dt) + (NRUN) * dt
INIT NSEA = 1904
INFLOWS:
NRUN = NLIT*0.000214
PHYT(t) = PHYT(t - dt) + (GRO - GRZ - MOP) * dt
INIT PHYT = 5
INFLOWS:
GRO = PHYT*(1-PHYT/20)*1.05^(TEMP-15.2)*15.3*MAX(NSEC/
(NSEC+2*10^(-7)),PSEC/(PSEC+3.5*10^(-8)))
OUTFLOWS:
GRZ =
PHYT*16*TEMP*1.05^(TEMP-15.2)
MOP = PHYT*4.5*1.05^(TEMP-15.2)
PLAL(t) = PLAL(t - dt) + (ASS - MOR - RES) * dt
INIT PLAL = 560

```

---

Continued

**Table 7.10** The Global Warming Model: Equations in the STELLA Format—cont'd

---

```

INFLOWS:
ASS = (120*13*CO2C)/(7*(CO2C+300))* (NLIT/865)*1.05^
  (TEMP-15.2)
OUTFLOWS:
MOR = 0.49*ASS
RES = 0.5*ASS
PLIT(t) = PLIT(t - dt) + (PPF - PRUB) * dt
INIT PLIT = 60
INFLOWS:
PPF = PFE*0.1
OUTFLOWS:
PRUB = PLIT*0.00005
PSEA(t) = PSEA(t - dt) + (PRUB) * dt
INIT PSEA = 129.5
INFLOWS:
PRUB = PLIT*0.00005
WATV(t) = WATV(t - dt) + (FFU - WEP) * dt
INIT WATV = 67580
INFLOWS:
FFU = 0.63*FFC+RES
OUTFLOWS:
WEP = 0.0547*(TEMP-15.2)
ZOOP(t) = ZOOP(t - dt) + (GRZ - REZ - MOZ) * dt
INIT ZOOP = 1
INFLOWS:
GRZ =
PHYT*16*TEMP*1.05^(TEMP-15.2)
OUTFLOWS:
REZ = ZOOP*10*1.05^(TEMP-15.2)
MOZ = (4.8*ZOOP+0.2222*ZOOP*PHYT)*1.05^(TEMP-15.2)
ALBE = 0.301+2.1*10^(-6)*(WATV-67580)+1.0*(CLOD-0.5)
BETA = 0.399+118*10^(-6)*(CO2C-350)+0.563*(CLOD-0.5)+
  2.73*10^(-6)*(WATV-67580)
CLOD = WATV*0.5/(67580)
CO2C = CO2A*29/(12*5.35)
COMC = CO2M*3800/(75*1.36*10^3)
FTIME = 1
Keel = 10+(8.4-pH)*0.7
NSEC = NSEA/1.36*10^9
pH = 8.4 -1.2* COMC/919
PSEC = PSEA/1.36*10^9
PTIME = 1.05
TEMP = (WS*(1-ALBE)/(28840*(1-BETA)))^0.25-273.3
WS = 1.73*10^14

```

---

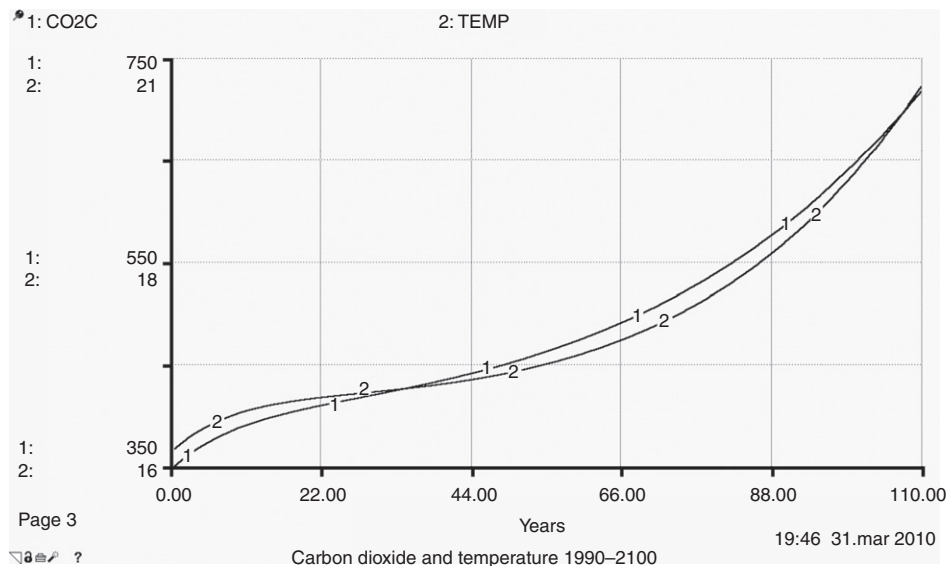


Water in the atmosphere, WATV  
 Nitrogen in the atmosphere, NITA  
 Nitrogen in the lithosphere, NLIT  
 Nitrogen in the hydrosphere, NSEA  
 Phosphorus in the lithosphere, PLIT  
 Phosphorus in the hydrosphere, PSEA  
 Carbon as carbon dioxide in the atmosphere, CO2A  
 Carbon in plant biomass in the lithosphere, PLAL  
 Carbon in detritus in the lithosphere, DETR  
 Carbon in the upper layer of the sea, CO2M  
 Carbon in phytoplankton in the sea, PHYT  
 Carbon in the zooplankton in the sea, ZOOP  
 Carbon in detritus in the sea, DTEM  
 Carbon in 6 deeper layers of the sea, CO2M2, CO2M3, . . . CO2M6,  
 CO2DS

The forcing functions are:

Use of fossil fuel, FFC  
 Use of nitrogen fertilizer, PFE  
 Use of phosphorus fertilizer, PPF

Figure 7.11 shows the model results corresponding to a 2% increase in the use of fossil fuels since time = 0, which represents 1990 as a reference year. The starting average global temperature is 15.71°C and the model simulation shows the temperature increasing to 20.16°C, corresponding to an increase of the global average temperature of about 4.5°C. The temperature in 2010 is 16.32 or 0.62 centigrade higher than in 1990. This value corresponds very closely to the recorded increase of the global average temperature during the last 20 years. The carbon dioxide concentration has increased from about 350 parts per million to about 390 parts per million in 2010, which also matches the measured carbon dioxide concentration increase in the atmosphere. The model simulation projects that carbon dioxide concentration is expected to be about 720 parts per million in 2100. If the temperature increase is to be held to only two degrees Celsius during this century as recommended by the climate panel of The United Nations, then it is necessary to phase out fossil fuel use during the next 30 to 50 years. A prediction based on a



**FIGURE 7.11** Model simulation showing atmospheric carbon dioxide concentration and the average global temperature from 1990 to 2100.

continuous 2% annual increase of fossil fuel use during the next ten years followed by a linear decrease to no fossil fuel use by 2070 shows a temperature increase to 18.1°C. This scenario results in a 1.78°C increase compared with today and 2.4°C higher than 1990.

The model has the following features and includes the following processes:

1. The global cycling of N, P, and C are included as the nitrogen and phosphorus cycles interact with the carbon cycle
2. The carbon dioxide diffusion in the sea is described by a multilayer model
3. The ability of the ocean to take up carbon dioxide is a function of pH, which is dependent on the carbon dioxide concentration relative to the concentrations of hydrogen carbonate and carbonate
4. The ability of the oceans to take up carbon dioxide is a function of the temperature
5. Increased photosynthesis by increased carbon dioxide concentration according to a Michaelis-Menten expression;  $CO_2C / (CO_2C + 300)$ ; see ASS [Table 7.10](#)

6. Water content in the atmosphere changed when the temperature changed and atmospheric water is also a greenhouse gas
7. The cloudiness changed when the water content in the atmosphere changed, which also changes the albedo;
8. Deforestation, 100,000 km<sup>2</sup> per year according to the Food and Agriculture Organization (FAO), is included
9. The change of albedo due to decreased ice coverage is estimated
10. The change in primary production in the sea, in wetlands, and in forests due to changed temperature and due to the increased carbon dioxide concentration (see also point 5) is considered
11. Permafrost melting for tundra regions is considered; it will decrease the albedo and increase the primary production

## Problems

1. Two alternatives exist for improving the visual quality of Lake X: (1) Increase the dilution (flushing) rate and (2) decrease the concentration of nutrients in the inflow by waste water treatment. The present detention time is 8 months and the average inflow of phosphorus, which is considered the most limiting nutrient, is 120 mg L<sup>-1</sup>. The lake can be considered a completely mixed reactor. Which alternative would you choose and why?
2. The average flow velocity of a stream is 0.7 m/s and the average depth is 1.5 m. Estimate the rate of oxygen transfer from the atmosphere to the water at 12, 15, and 20°C.
3. A stream has the following characteristics during a low flow period: flow rate 70 m<sup>3</sup> s<sup>-1</sup> and 0.4 m s<sup>-1</sup>, temperature 24°C, depth 2 m, dissolved oxygen 85%, and BOD<sub>5</sub> 2 mg/L at point X. How many kg of BOD<sub>5</sub> can be discharged into the stream at point X, if a minimum of 5 mg/L is to be maintained in the stream? Average rate constants can be assumed. Nitrification is negligible.
4. A stream receives wastewater at a rate of 7 m<sup>3</sup> s<sup>-1</sup>. The wastewater has BOD<sub>5</sub> 12 mg/L and the ammonium concentration is 23 mg/L. The stream has a flow rate of 60 m<sup>3</sup> s<sup>-1</sup> and 0.5 m s<sup>-1</sup>, temperature 18°C, depth 2 m, dissolved oxygen 95%. Which minimum oxygen concentration will be recorded in the stream at which

distance from the discharge point? Use the constant presented in the text.

5. Estimate the difference in the estimation of the reaeration coefficient using all of the expressions in the text.
6.  $BOD_5$  at room temperature  $20^\circ\text{C}$  is found to be  $14\text{ mg/L}$  in a sample. What is  $BOD_7$  at  $18^\circ\text{C}$ ?
7. Determine the  $BOD_5$  and the oxygen concentration in a completely mixed lake with an inflow of  $40\text{ L/s}$ , a depth of  $3\text{ m}$  and an area of  $15\text{ ha}$ . The average wind speed is approximately  $4.5\text{ m/s}$ , the oxygen concentration in the inflow is  $8\text{ mg/L}$  and contains no BOD.  $120\text{ kg}$  of BOD is discharged to the lake by waste water per day. The lake has a sandy bottom. The photosynthesis corresponds to  $3\text{ mg oxygen/(l day)}$ .
8. Set up a STELLA program for Lorenzen's model.
9. Explain why the relationship between summer chlorophyll and annual average phosphorus concentration is so different for the various investigations of the relationship.
10. Find the transparency for a lake with an annual average phosphorus concentration of  $1\text{ mg/L}$  and a depth of  $2\text{ m}$  using [Table 7.5](#). Use [Eq. \(7.13\)](#) to find the chl. a. concentration and [Figure 7.3](#). Explain the discrepancy.
11. Explain why any new lake model development inevitably requires an examination of possible model modifications.
12. Why is validation of a model compulsory?
13. How will you describe the generality of eutrophication models?
14. Explain why it is expected that a structural dynamic model will be able to offer a better validation.

# APPENDIX 1

**TABLE 1** Dissolved oxygen (ppm, mg/l) in fresh, brackish and sea water at different temperatures and at different chlorinities (%). Values are at saturation

Temp	0%	0.2%	0.4%	0.6%	0.8%	1.0%	1.2%	1.4%	1.6%	1.8%	2.0%
1	14.24	13.87	13.54	13.22	12.91	12.58	12.29	11.99	11.70	11.42	11.15
2	13.74	13.50	13.18	12.88	12.56	12.26	11.98	11.69	11.40	11.13	10.86
3	13.45	13.14	12.84	12.55	12.25	11.96	11.68	11.39	11.12	10.85	10.59
4	13.09	12.79	12.51	12.22	11.93	11.65	11.38	11.10	10.83	10.59	10.34
5	12.75	12.45	12.17	11.91	11.63	11.36	11.09	10.83	10.57	10.33	10.10
6	12.44	12.15	11.86	11.60	11.33	11.07	10.82	10.56	10.32	10.09	9.86
7	12.13	11.85	11.58	11.32	11.06	10.82	10.56	10.32	10.07	9.84	9.63
8	11.85	11.56	11.29	11.05	10.80	10.56	10.32	10.07	9.84	9.61	9.40
9	11.56	11.29	11.02	10.77	10.54	10.30	10.08	9.84	9.61	9.40	9.20
10	11.29	11.03	10.77	10.53	10.30	10.07	9.84	9.61	9.40	9.20	9.00
11	11.05	10.77	10.53	10.29	10.06	9.84	9.63	9.41	9.20	9.00	8.80
12	10.80	10.53	10.29	10.06	9.84	9.63	9.41	9.21	9.00	8.80	8.61
13	10.56	10.30	10.07	9.84	9.63	9.41	9.21	9.01	8.81	8.61	8.42
14	10.33	10.07	9.86	9.63	9.41	9.21	9.01	8.81	8.62	8.44	8.25
15	10.10	9.86	9.64	9.43	9.23	9.03	8.83	8.64	8.44	8.27	8.09
16	9.89	9.66	9.44	9.24	9.03	8.84	8.64	8.47	8.28	8.11	7.94
17	9.67	9.46	9.26	9.05	8.85	8.65	8.47	8.30	8.11	7.94	7.78
18	9.47	9.27	9.07	8.87	8.67	8.48	8.31	8.14	7.97	7.79	7.64
19	9.28	9.08	8.88	8.68	8.50	8.31	8.15	7.98	7.80	7.65	7.49
20	9.11	8.90	8.70	8.51	8.32	8.15	7.99	7.84	7.66	7.51	7.36
21	8.93	8.72	8.54	8.35	8.17	7.99	7.84	7.69	7.52	7.38	7.23
22	8.75	8.55	8.38	8.19	8.02	7.85	7.69	7.54	7.39	7.25	7.11
23	8.60	8.40	8.22	8.04	7.87	7.71	7.55	7.41	7.26	7.12	6.99
24	8.44	8.25	8.07	7.89	7.72	7.56	7.42	7.28	7.13	6.99	6.86
25	8.27	8.09	7.92	7.75	7.58	7.44	7.29	7.15	7.01	6.88	6.85
26	8.12	7.94	7.78	7.62	7.45	7.31	7.16	7.03	6.89	6.86	6.63
27	7.98	7.79	7.64	7.49	7.32	7.18	7.03	6.91	6.78	6.65	6.52
28	7.84	7.65	7.51	7.36	7.19	7.06	6.92	6.79	6.66	6.53	6.40
29	7.69	7.52	7.38	7.23	7.08	6.95	6.82	6.68	6.55	6.42	6.29
30	7.56	7.39	7.25	7.12	6.96	6.83	6.70	6.58	6.45	6.32	6.19